

Series 200

UPS and UPSD circulator pumps
50 Hz

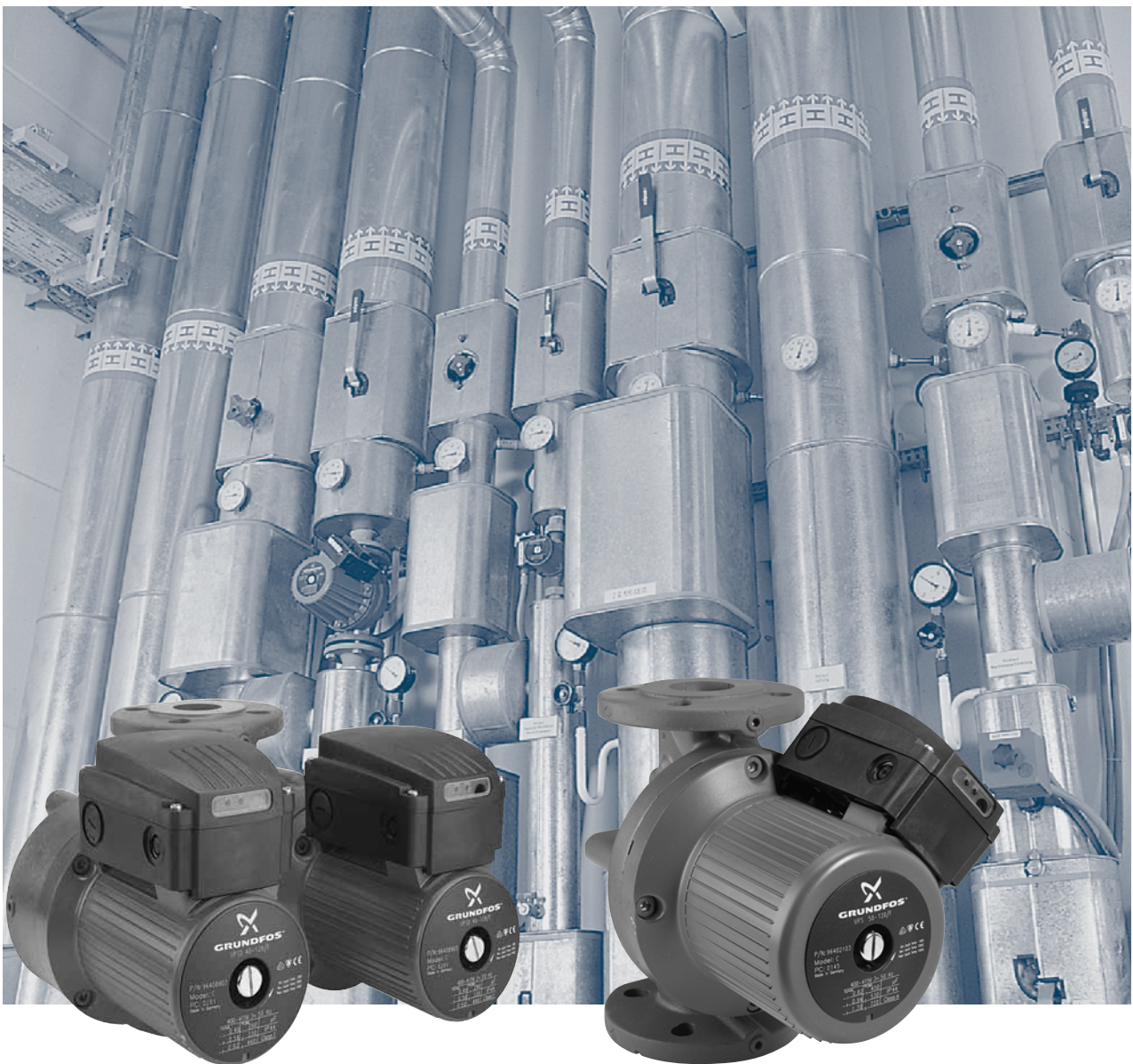

Contents

General data

Performance range	3
Product range	4
Single-head pumps	4
Twin-head pumps	5
Type key	5
Energy labelling	5
Applications	6
Heating systems	6
Domestic hot water systems	6
Cooling and air-conditioning systems	6

Functions

Speed switch	7
Standard module	7
Pumps with protection module	7
Protection module indicator lights	8
Relay module	8
Operating modes of twin-head pumps	9

Connection

Electrical data	10
Electrical connection	10
Pumps with standard module	10
Single-head pumps with protection module	11
Single-head pump with relay module	11
Twin-head pumps with relay module	12
Signal output of twin-head pumps	13
Installation	13
Terminal box positions	13

Construction

Construction	14
Material specification	14
Sectional drawing	14

Technical data

Pumped liquids	15
Temperature limits	15
Technical data	15
Curve conditions	15

Data sheet

UPS 32-30 F 220, UPSD 32-30 F 220	16
UPS 32-60 F 220, UPSD 32-60 F 220	17
UPS 32-120 F 220, UPSD 32-120 F 220	18
UPS 40-30 F 250, UPSD 40-30 F 250	19
UPS 40-30 F 254	20
UPS 40-60/4 F 250	21
UPS 40-60/2 F 220	22
UPS 40-60/2 F 250, UPSD 40-60/2 F 250	23
UPS 40-120 F 250, UPSD 40-120 F 250	24
UPS 40-180 F 250	25
UPS 40-185 F 250	26
UPS 50-30 F 280, UPSD 50-30 F 280	27
UPS 50-60/4 F 280, UPSD 50-60/4 F 280	28
UPS 50-60/2 F 280, UPSD 50-60/2 F 280	29
UPS 50-60/2 F 300	30
UPS 50-120 F 280, UPSD 50-120 F 280	31
UPS 50-180 F 280, UPSD 50-180 F 280	32
UPS 50-185 F 280	33
UPS 65-30 F 340, UPSD 65-30 F 340	34
UPS 65-60/4 F 340, UPSD 65-60/4 F 340	35
UPS 65-60/2 F 340, UPSD 65-60/2 F 340	36
UPS 65-60/2 F 280	37
UPS 65-120 F 280	38
UPS 65-120 F 340, UPSD 65-120 F 340	39
UPS 65-180 F 340, UPSD 65-180 F 340	40
UPS 65-185 F 340	41
UPS 80-30 F 360, UPSD 80-30 F 360	42
UPS 80-60 F 360, UPSD 80-60 F 360	43
UPS 80-120 F 360, UPSD 80-120 F 360	44
UPS 100-30 F 450, UPSD 100-30 F 450	45

Accessories

Accessories	46
Counter flanges	46
Protection modules	46
Relay module	46
Insulation kits	47
Base plate	47
Blanking flanges	48

Further product documentation

WebCAPS	49
WinCAPS	50

Performance range

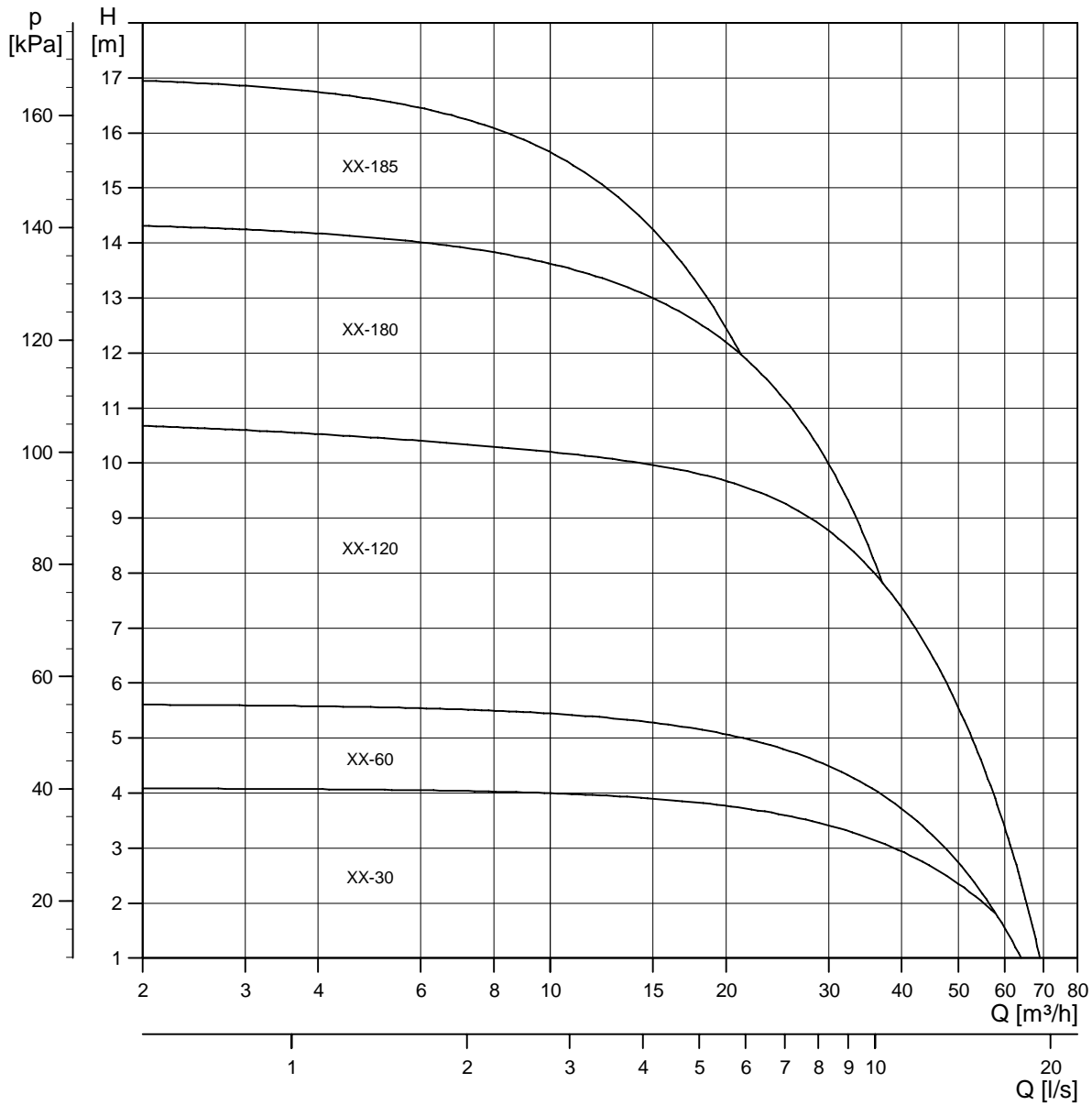

TM03 3344 0806

Product range

Single-head pumps

Pump type	Pressure stage						Voltage [V]			Poles	
	PN 6/ PN 10	PN 6	PN 10	PN 6 / PN 10 bronze	PN 6 bronze	PN 10 bronze	1 x 230-240	3 x 230	3 x 400-415	2	4
UPS 32-30 F 220	•			•			•	•	•		•
UPS 32-60 F 220	•			•			•	•	•	•	
UPS 32-120 F 220	•			•			•	•	•	•	
UPS 40-30 F 250	•			•			•	•	•		•
UPS 40-30 F 254 *	•								•		•
UPS 40-60/2 F 220 *	•								•	•	
UPS 40-60/2 F 250	•			•			•	•	•	•	
UPS 40-60/4 F 250	•			•			•	•	•		•
UPS 40-120 F 250	•			•			•	•	•	•	
UPS 40-180 F 250	•			•			•	•	•	•	
UPS 40-185 F 250	•						•		•	•	
UPS 50-30 F 280	•			•			•	•	•		•
UPS 50-60/2 F 280	•			•			•	•	•	•	
UPS 50-60/2 F 300 *	•								•	•	
UPS 50-60/4 F 280	•			•			•	•	•		•
UPS 50-120 F 280	•			•			•	•	•	•	
UPS 50-180 F 280	•			•			•	•	•	•	
UPS 50-185 F 280	•						•		•	•	
UPS 65-30 F 340	•			•			•	•	•		•
UPS 65-60/2 F 280 *	•								•	•	
UPS 65-60/2 F 340	•			•			•	•	•	•	
UPS 65-60/4 F 340	•			•			•	•	•		•
UPS 65-120 F 280 *	•								•	•	
UPS 65-120 F 340	•			•			•	•	•	•	
UPS 65-180 F 340	•			•				•	•	•	
UPS 65-185 F 340	•								•	•	
UPS 80-30 F 360		•	•		•	•		•	•		•
UPS 80-60 F 360		•	•		•	•		•	•		•
UPS 80-120 F 360		•	•		•	•		•	•	•	
UPS 100-30 F 450		•	•		•	•		•	•		•

Twin-head pumps

Pump type	Pressure stage						Voltage [V]			Poles	
	PN 6/ PN 10	PN 6	PN 10	PN 6 /PN 10 bronze	PN 6 bronze	PN 10 bronze	1 x 230-240	3 x 230	3 x 400-415	2	4
UPSD 32-30 F 220	•						•	•	•		•
UPSD 32-60 F 220	•						•	•	•	•	
UPSD 32-120 F 220	•						•	•	•	•	
UPSD 40-30 F 250	•						•	•	•		•
UPSD 40-60 F 250	•						•	•	•	•	
UPSD 40-120 F 250	•						•	•	•	•	
UPSD 50-30 F 280	•						•	•	•		•
UPSD 50-60/2 F 280	•						•	•	•	•	
UPSD 50-60/4 F 280	•						•	•	•		•
UPSD 50-120 F 280	•						•	•	•	•	
UPSD 50-180 F 280	•						•	•	•	•	
UPSD 65-30 F 340	•						•	•	•		•
UPSD 65-60/2 F 340	•						•	•	•	•	
UPSD 65-60/4 F 340	•						•	•	•		•
UPSD 65-120 F 340	•						•	•	•	•	
UPSD 65-180 F 340	•							•	•	•	
UPSD 80-30 F 360		•	•					•	•		•
UPSD 80-60 F 360		•	•					•	•		•
UPSD 80-120 F 360		•	•					•	•	•	
UPSD 100-30 F 360		•	•					•	•		•

Type key

Example	UPS	(D)	65	-60	(/2)	F(-)	280
Type range	-----						
Twin-head pump	-----						
Nominal flange diameter [mm]	-----						
Max. head [dm]	-----						
Number of motor poles, (stated if available both as 2- and 4-pole motor)	-----						
F - Pump with flanges	-----						
B - Pump with bronze housing	-----						
Port-to-port length [mm]	-----						

Energy labelling

Grundfos UPS circulator pumps are provided with the energy label, except the bronze pumps (B-version).

The energy label indicates the energy-saving level of the pump. The energy classification system has seven levels, i.e. from A to G. Level A is the best.

The energy label can be used to compare pumps of the same type and size.

The energy labelling of the pumps are stated on the data sheet of the pump in question.

Applications

Grundfos circulator pumps, types UPS, UPSD, are designed for circulation of liquids in heating and air-conditioning systems. Pumps with bronze pump housings are suitable for circulation in domestic hot water systems.

General examples of systems in which UPS, UPSD pumps are suitable are shown below.

UPS, UPSD are a complete line of circulator pumps with three speeds.

The pumps come both as single and twin-head pumps.

Heating systems

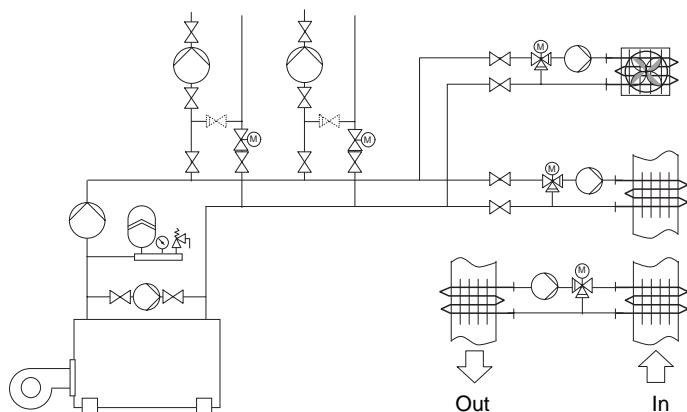

- One- and two-pipe heating systems
- Main pumps
- Zone pumps
- Boiler shunt pumps
- Pumps for heating surfaces
- Calorifers
- Underfloor heating systems
- Solar heating systems
- Geothermal heating systems
- Heat recovery systems

TM01 0168 0697

Domestic hot water systems

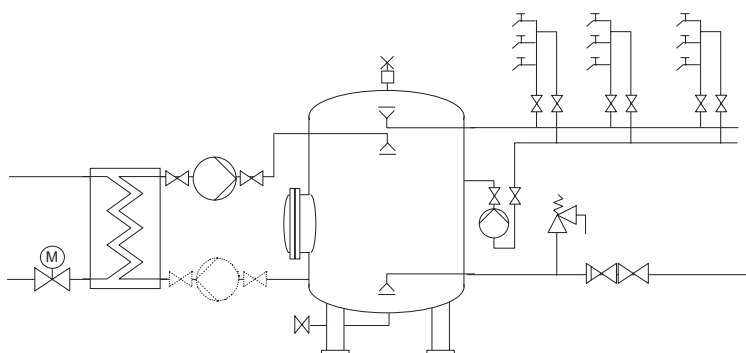

- Domestic hot water systems

TM01 0169 0697

Cooling and air-conditioning systems

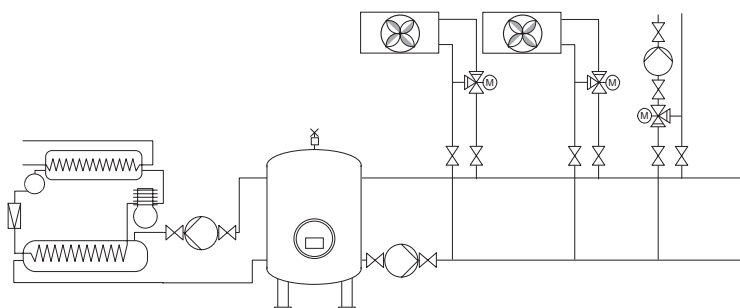

- Two-pipe air-conditioning systems
- Main pumps
- Zone pumps
- Pumps for refrigeration units
- Heat pump systems
- Geothermal heating systems
- Heat recovery systems

TM01 0170 0697

Speed switch

The pump offers three speeds for adjustment of pump performance to the system in question.

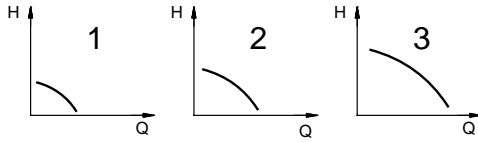

TM00 9247 4595

Fig. 1 Pump performance at the three speeds

The speeds of the various speed switch positions are shown in the table below:

Switch position	Speed in % of maximum speed	
	Single-phase pumps	Three-phase pumps
1	approx. 60 %	approx. 70 %
2	approx. 80 %	approx. 85 %
3	100 %	100 %

Change to a lower speed enables reduction in energy consumption and less noise in the system.

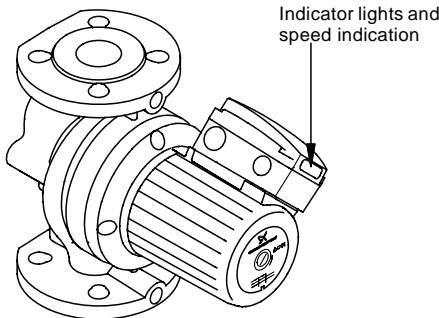

TM00 9747 0602

Fig. 2 Indicator lights on terminal box

Standard module

The module is standard in single-head pumps and is also available for twin-head pumps.

Connect the pump to the mains via an external contactor. Connect the contactor to the pump's built-in thermal overload switch to protect the pump against overload at all three speeds.

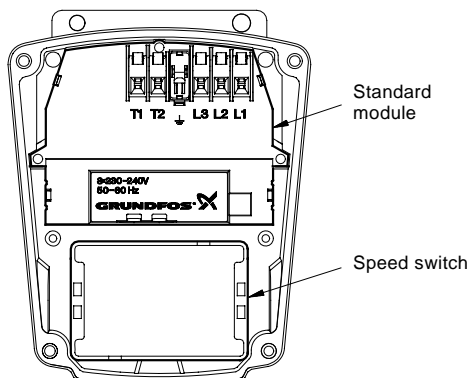

TM00 9237 0602

Fig. 3 Standard module

Indicator lights on standard module

The function of the indicator lights on the terminal box is as shown in the following tables.

Single-phase pumps

Single-phase pumps incorporate a green indicator light only:

Indicator light	Description
On	The electricity supply has been switched on.
Off	The electricity supply has been switched off.

Three-phase pumps

Three-phase pumps incorporate a green and a red indicator light:

Indicator lights		Description
Green	Red	
Off	Off	The electricity supply has been switched off.
On	Off	The electricity supply has been switched on.
On	On	The electricity supply has been switched on. The direction of rotation is wrong.

Pumps with protection module

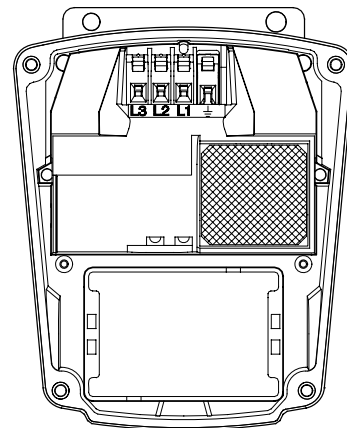

TM01 3879 4798

Fig. 4 Protection module

Protection module

The protection module is supplied as an accessory for single-head and twin-head pumps.

When equipped with a protection module, the pump can be connected to an external switch directly, as the built-in protection against overheating protects the pump at all three speeds. Furthermore, the module has two indicator lights.

Protection module indicator lights

The function of the indicator lights is shown in the table below.

Indicator lights		Description
Green	Red	
Off	Off	The pump has been stopped. The electricity supply has been switched off, thermally cut out or a phase is failing.
On	Off	The pump is operating.
On	On	Three-phase pumps only: The pump is operating, but the direction of rotation is not correct.
Off	On	The pump has been cut out by the thermal switch.

Note: Pumps with protection module must not be connected to a frequency converter.

Relay module

The relay module is standard in twin-head pumps and an **optional extra** for single-head pumps.

The module enables direct connection of the pump to an external mains switch and an external operating or fault indication device. The signal output for an external signal device can be set to activation during operation or fault by means of the selector switch.

As standard, the signal outputs of relay modules in twin-head pumps are interconnected so that the pumps are operating alternately as duty pump and standby pump.

The pump is connected directly to the mains as the pump incorporates overload protection at all three speeds. If the pump has been cut out by the thermal overload switch, it will restart automatically when it has cooled to normal temperature, provided the external on/off contact is closed.

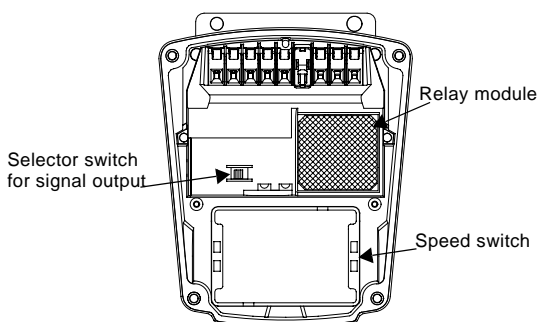

TM00 9236 4596

Fig. 5 Relay module

Indicator lights on relay module

The indicator lights on pumps with relay module have more detailed operating and fault indications.

All pumps with relay module are equipped with a green and a red indicator light. Their functions are as shown in the table below.

Signal output of relay module

The relay module is equipped with a signal output for external operating or fault indication.

By means of the selector switch, the output can be used as:

- Operation signal output between terminals 2 and 3 or
- Fault signal output between terminals 1 and 3.

Functions of indicator lights and signal output

Indicator lights		Signal output		Description
Green	Red	Operation	Fault	
Off	Off			The pump has been stopped. The electricity supply has been switched off or a phase is failing.
Permanently on	Off			The pump is running.
Permanently on	Permanently on			Only three-phase pumps: The pump is running, but with wrong direction of rotation.
Off	Permanently on			The pump has been cut out by the thermal overload switch.
Flashes	Off			The pump has been stopped by an external on/off switch.
Flashes	Permanently on			The pump is or has been cut out by the thermal overload switch and it has been stopped by an external on/off switch.

Note: Pumps with relay module must not be connected to a frequency converter.

Operating modes of twin-head pumps

Twin-head pumps have a relay module in both terminal boxes, which are interconnected by a 4-core cable.

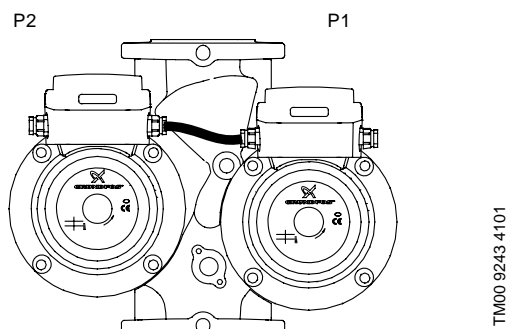

Fig. 6 Twin-head pump

In addition to the signal functions, the signal output of the relay module for twin-head pumps can be used for controlling the operating mode of pump 1 and 2. It is possible to choose between three operating modes:

1. **Alternating operation (factory setting).** The pumps operate alternately as duty and standby pump, respectively. Changeover takes place every 24 hours. If the duty pump is cut out due to a fault, the standby pump will automatically start. During changeover both pumps will be running for a short period to ensure a low-noise changeover.
2. **Standby operation.** The pumps operate continuously as duty and standby pump, respectively. If the duty pump is cut out due to a fault, the standby pump will automatically start at a signal from the output of the duty pump. The sequence can be changed to make the standby pump operate as duty pump.
3. **Single-pump operation.** The pumps run independently without communicating with each other.

Electrical data

Supply voltage and frequency:	1 x 230-240 V, 50 Hz 3 x 230 V, 50 Hz 3 x 400-415 V, 50 Hz.
Motor protection:	The pump requires no external motor protection if the motor is fitted with a protection module.
Back-up fuse:	Max. 10 A.
Enclosure class:	IP 44.
Insulation class:	H.
Screwed cable entries:	1 x M20 for mains connection. 1 x M20 for signal output (blanked-off if pump with standard module). 1 x M16 for capacitor connection (only single-phase pumps).
EMC (electromagnetic compatibility):	EN 61 000-6-2. EN 61 000-6-3.

Thermal overload switch

Voltage	250 V AC
Current	cos phi = 1.0: 2.5 A cos phi = 0.6: 1.6 A

Start/stop input (relay module)

External potential-free contact.	
Maximum load:	250 V, 1.5 mA.
Minimum load:	100 V, 0.5 mA.

Operating/fault signal output (relay module)

Internal potential-free changeover contact.	
Maximum load:	250 V, 2 A, AC.
Minimum load:	5 V, 100 mA, DC.

Electrical connection

The electrical connection and protection should be carried out in accordance with local regulations. Earthing or neutralization can be used for protection against indirect contact. A current- or voltage-operated earth-leakage circuit breaker can be used as extra protection.

Never make any connections in the pump terminal box unless the electricity supply has been switched off.

The pump must be earthed and connected to an external mains switch.

The operating voltage and frequency are marked on the pump nameplate. Make sure that the motor is suitable for the electricity supply on which it will be used.

Pumps with standard module

The pump must be connected to the mains via an external contactor. The contactor is to be connected to the pump's built-in thermal overload switch at terminals T1 and T2 to protect the pump against overheating at all three speeds.

Note: If the pump is also protected by means of a motor starter, the starter must be set to the current consumption of the pump at the chosen speed. The motor starter setting must be changed every time the pump speed is changed. The current consumption at the various speeds is stated on the pump nameplate.

External impulse switches

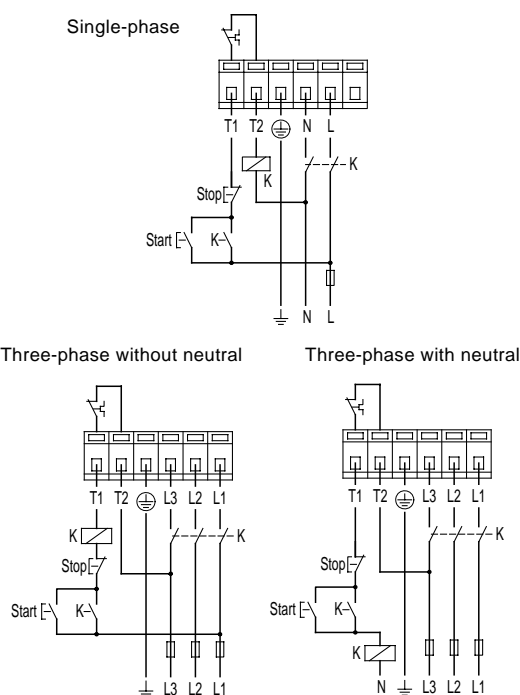

Fig. 7 External impulse switches

TM00 9173 0305

External changeover switch

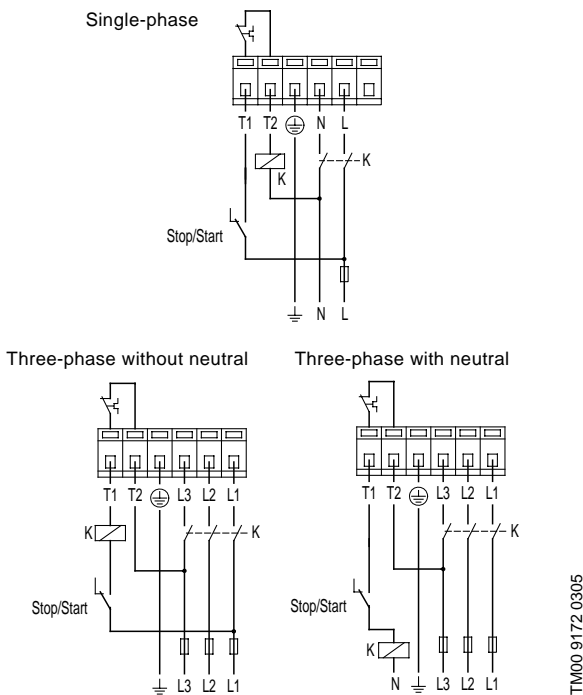

Fig. 8 External changeover switch

Single-head pumps with protection module

The pump can be connected directly to the mains as the pump features built-in protection against overheating at all three speeds.

The figure below shows the electrical connection of single-phase and three-phase pumps.

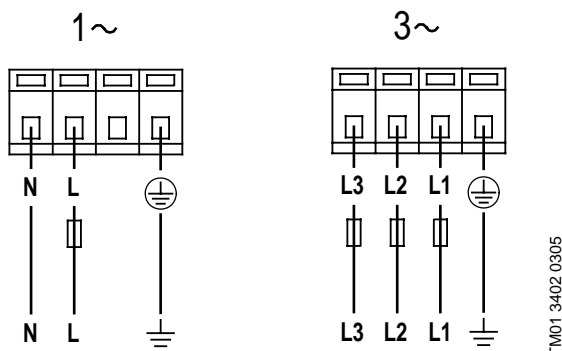
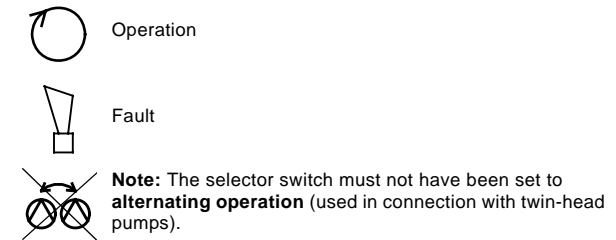

Fig. 9 Electrical connections, protection module

Single-head pump with relay module

The pump can be connected directly to the mains as it incorporates protection against overheating at all three speeds.

The relay module has a signal output for an external operating or fault signal device. By means of the selector switch the signal output can be used as operation or fault signal output:



Operating indication

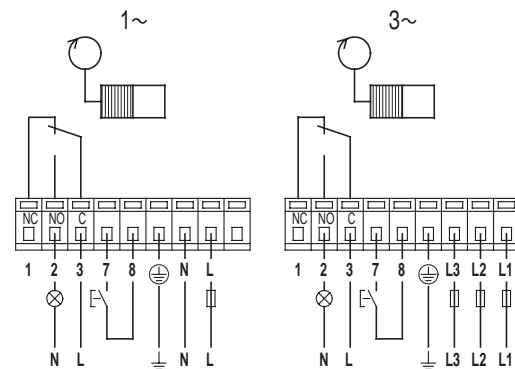

Fig. 10 Operating indication

Fault indication

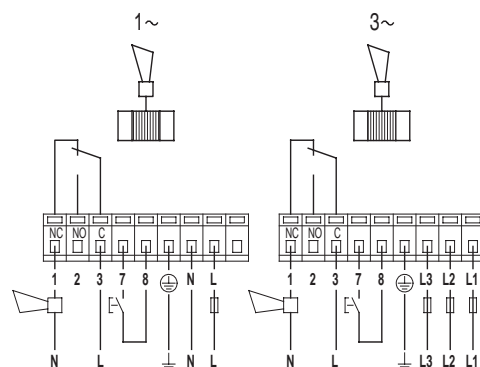

Fig. 11 Fault indication

Twin-head pumps with relay module

The pumps are interconnected by a 4-core cable and factory-set to operating alternately as duty and standby pump. Changeover takes place every 24 hours. The following figures shows the electrical connections and the selector switch setting for the various operating modes.

Alternating operation (factory setting)

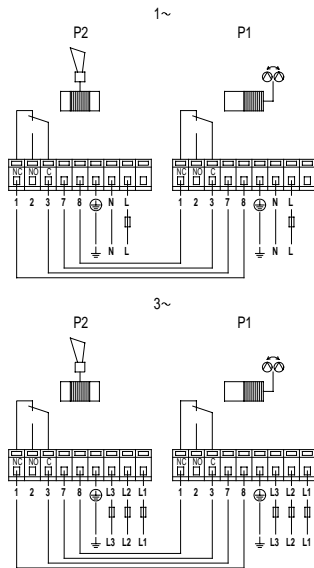

Fig. 12 Alternating operation

Standby operation

Standby operation with pump 1 as duty pump and pump 2 as standby pump.

Note: In this operating mode the selector switch of pump 2 must not have been set to alternating operation.

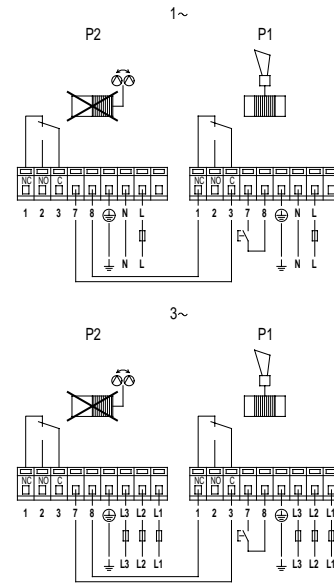

Fig. 13 Standby operation

Standby operation with pump 2 as duty pump and pump 1 as standby pump.

Note: In this operating mode the selector switch of pump 1 must not have been set to alternating operation.

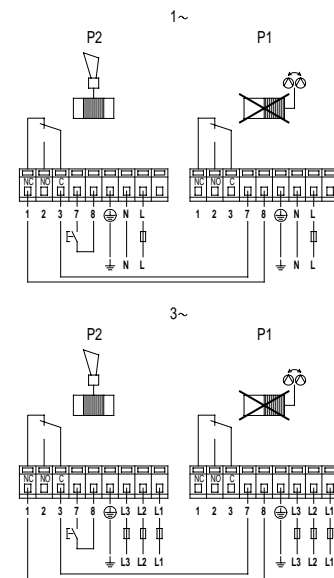

Fig. 14 Standby operation

In the case of single-pump operation the cable between the pumps is to be removed. The pumps must be set individually and connected separately to mains, see page 11 "Single-head pump with relay module".

TM00 9176 0305

TM00 9177 0305

TM00 9178 0305

Signal output of twin-head pumps

The signal output of twin-head pumps can be used directly, **provided** it is not already being used for communication between the pumps.

If an output that is used for communication between the pumps is to be used as signal output, an intermediate relay is required. See example below.

The example shows a single-phase pump in alternating operation with external fault indication in case of fault on pump 2 or both pumps.

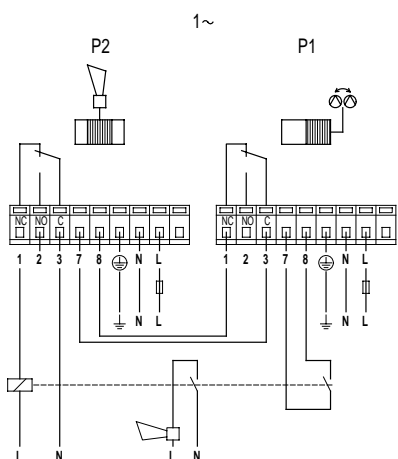

Fig. 15 Alternating operation with external fault indication

TM00 9179 0305

Installation

The pump must be installed with horizontal motor shaft.

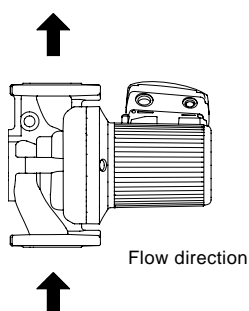

Fig. 16 Flow direction

TM02 1404 1101

Note: Twin-head pumps in vertical pipes with downward liquid flow or in horizontal pipes must always run at maximum speed.

Twin-head pump mounted in horizontal pipes must be fitted with an automatic air vent in the upper part of the pump housing.

Terminal box positions

Single-head pumps

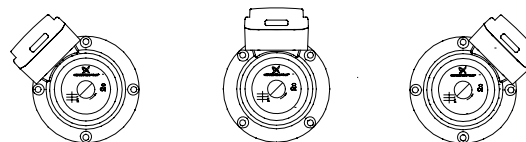

TM02 1398 1101

Fig. 17 Permissible terminal box positions

Twin-head pumps

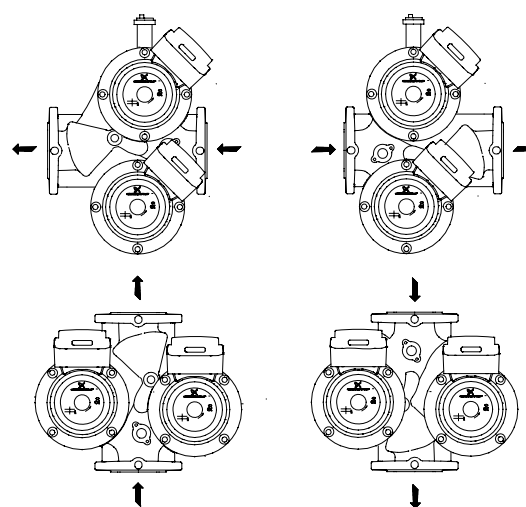

TM02 1399 1101

Fig. 18 Permissible terminal box positions and flow direction of twin-head pumps

For standard terminal box positions, see technical data from page 15.

Construction

The UPS, UPSD pumps are of the canned rotor type, i.e. pump and motor form an integral unit without shaft seal and with only two gaskets for sealing. The bearings are lubricated by the pumped liquid. Attention has been focused on using as few materials as possible, and the use of materials that might cause problems in connection with disposal have been omitted.

The pump offers these features:

- Three-speed motor
- Ceramic radial bearings
- Carbon thrust bearing
- Stainless-steel rotor can, bearing plate and rotor cladding
- Aluminium-alloy stator housing
- Cast iron or bronze pump housing
- Stator with built-in thermal overload switch.

Material specification

Pos.	Description	Material	DIN W.-Nr.
1	Terminal box	Composite PA66	
2	Inspection screw	Brass with nickel	
3	Nameplate	Composite PA66	
4	Stator housing	Aluminium AISi 10Cu2	
	Stator windings	Copper wire	
	Stator winding cap	Composite PETP	
5	Cheese-head screw	Steel 8.8	
6	O-rings	EPDM rubber	
7	Outer bearing ring	Aluminium oxide/SiC	
	Rotor can	Stainless steel	1.4301
8	Shaft (cast iron pumps)	Stainless steel	1.4305
	Shaft (bronze pumps)	Stainless steel	1.4404
	Rotor cladding	Stainless steel	1.4301
9	Thrust bearing	Carbon MY 106	
10	Bearing plate	Stainless steel	1.4301
	Inner bearing ring	Aluminium oxide/SiC	
11	Stop ring	Stainless steel	1.4435
12	Split cone	Stainless steel	1.4305
13	Impeller	Stainless steel	1.4301
14	Nut	Stainless steel	1.4305
15	Neck ring	Stainless steel / PTFE	1.4301
		Cast iron EN-GJL-250	EN-JL-1040
16	Pump housing	Bronze CuSn10, DIN 1705	2.1050.01
17	Anti-friction ring	Brass/Stainless steel	
		Non-return flap (Twin-head pumps)	EPDM rubber
18	Splash protection	Stainless steel	1.4305

Sectional drawing

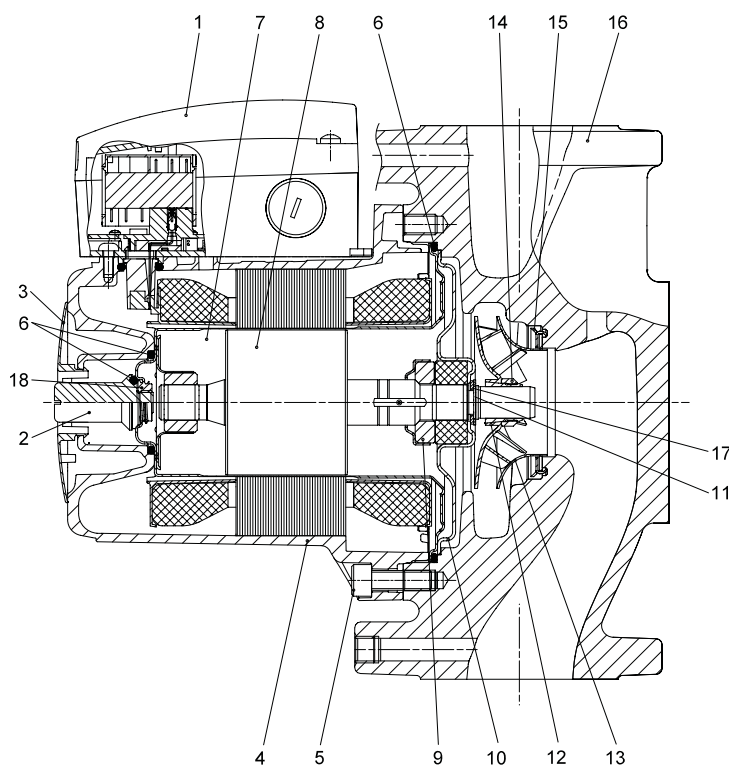

Fig. 19 Sectional drawing

TM02 1397 2102

Pumped liquids

Thin, clean, non-aggressive and non-explosive liquids, not containing any solid particles, fibres or mineral oil. In domestic hot water systems, it is advisable to use bronze pumps only for water with a degree of hardness lower than approx. 14 °dH. For water with a higher degree of hardness, use a close-coupled pump type TP.

If the pump is installed in a heating system, the water should meet the requirements of accepted standards on water quality in heating systems, e.g. the German standard VDI 2035.

The pumps **must not** be used for the transfer of inflammable liquids such as diesel oil and petrol.

Temperature limits

Ambient temperature: 0 °C to 40 °C

Liquid temperature

- for short periods: +140 °C
- continuously: -10 °C to +120 °C
- domestic hot water: Up to +60 °C

Storage temperature: -30 °C to +55 °C.

Depending on the cast-iron version and the pump application, the maximum liquid temperature may be limited by local regulations and laws.

Technical data

Relative humidity: Max. 95 %.

Sound-pressure level: The sound-pressure level of the pump is lower than 41 dB(A) (reference: 20 mPa).

Test pressure: PN 6: 10 bar ~ 1.0 MPa
PN 10: 15 bar ~ 1.5 MPa
PN 6/10: 15 bar ~ 1.5 MPa.

Test liquid: +20 °C water containing corrosion inhibitor.

Inlet pressure

To avoid cavitation noise, the following minimum pressures are required at the pump suction flange:

Pump type	Liquid temperature		
	75°C	90°C	120°C
UPS, UPSD	[bar]	[bar]	[bar]
32-30 F 220	0.05	0.05	1.3
32-60 F 220	0.05	0.2	1.5
32-120 F 220	0.4	0.7	1.95
40-30 F 250	0.05	0.15	1.45
40-30 F 254*	0.05	0.15	1.45
40-60/4 F 250	0.05	0.05	1.3
40-60/2 F 220*	0.05	0.2	1.5
40-60/2 F 250	0.15	0.45	1.75
40-120 F 250	0.1	0.4	1.7
40-180 F 250	0.4	0.7	1.95
40-185 F 250	0.55	0.90	1.8
50-30 F 280	0.05	0.1	1.4
50-60/4 F 280	0.05	0.15	1.45
50-60/2 F 280	0.05	0.35	1.65
50-60/2 F 300*	0.15	0.45	1.75
50-120 F 280	0.4	0.7	1.95
50-180 F 280	0.35	0.65	1.9
50-185 F 280	0.85	1.0	2.15
65-30 F 340	0.4	0.7	1.95
65-60/4 340	0.55	0.85	2.1
65-60/2 F 280*	0.05	0.35	1.65
65-60/2 340	0.45	0.75	2.0
65-120 F 280*	0.4	0.7	1.95
65-120 F 340	0.9	1.2	2.45
65-180 F 340	0.7	1.0	2.25
65-185 F 340	0.9	1.3	2.35
80-30 F 360	1.15	1.45	2.7
80-60 F 360	1.2	1.5	2.75
80-120 F 360	1.6	1.9	3.15
100-30 F 450	1.05	1.35	2.6

* Only available as single-head pump (UPS)

Curve conditions

The guidelines below apply to the performance curves in the following data sheets:

1. Due to the danger of overheating the pumps must not be used at a flow below 0.1 x Q at best efficiency point.
2. The **bold** parts of the curves show the **recommended** performance range.
3. Test liquid: Airless water.
4. The curves apply to a liquid temperature of 20 °C.
5. All curves show average values and **should not be used as guarantee curves**. If a stated minimum performance is required, individual measurements must be made.
6. The conversion between head H [m] and pressure p [kPa] has been made for water with a density of $\rho = 1000 \text{ kg/m}^3$. For liquids with other densities, e.g. hot water, the discharge pressure is proportional with the density.
7. Power curves, efficiency curves and electrical data for twin-head pumps apply to single-pump operation.

UPS 32-30 F 220, UPSD 32-30 F 220

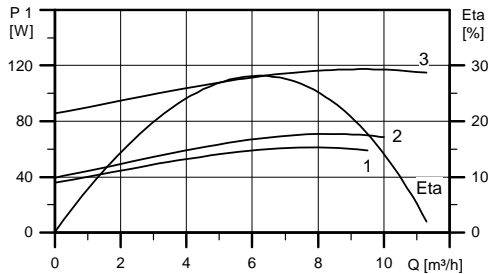
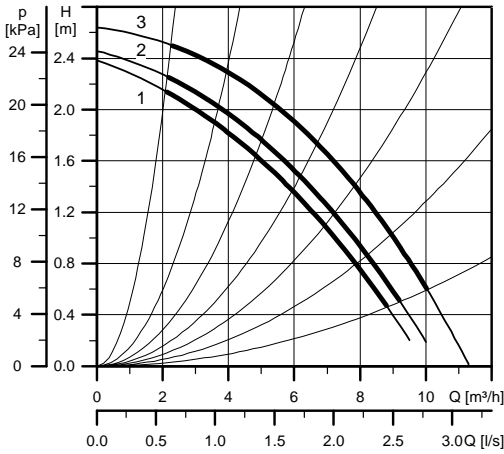

TMA0 9419 0497

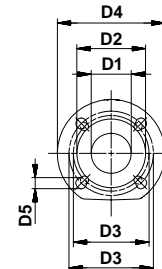
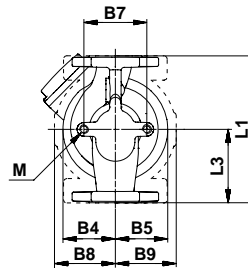
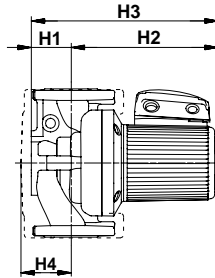
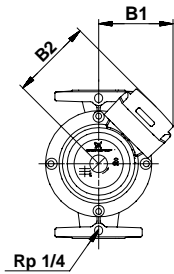

TM02 0701 3601

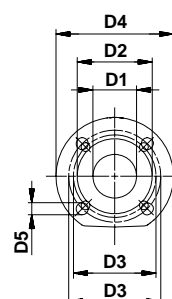
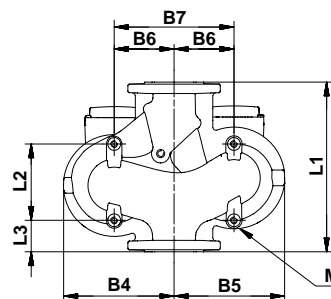
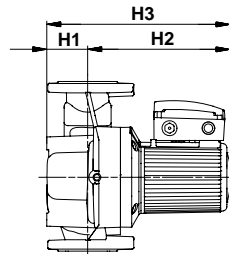
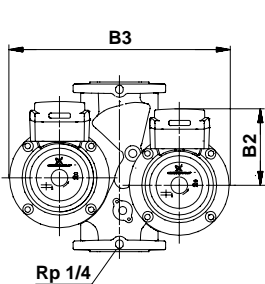

TM02 0703 3601

Inlet pressure

t_m [°C]	75	90	120
H_{min} [bar]	0.05	0.05	1.3

Electrical data

	P_{max} [W]	P_{min} [W]	I1/1 [A]	Cos ϕ	
3 x 230 V	Speed 1	60	35	0.26	0.58
	Speed 2	70	40	0.31	0.56
	Speed 3	115	85	0.87	0.33
3 x 400-415 V	Speed 1	60	35	0.15	0.58
	Speed 2	70	40	0.18	0.56
	Speed 3	115	85	0.50	0.33

Series 200 is also available for 1 x 230-240 V.

Single-head pumps are available with bronze housing, type B.

Energy labelling

Pump type	Energy class	
	3 x 230 V	3 x 400-415 V
UPS 32-30 F 220	D	E
UPSD 32-30 F 220	D	E

Dimensions and weights

Pump type	PN	Dimensions [mm]																	Weights [kg]*		Ship. vol. [m³]				
		L1	L2	L3	B1	B2	B3	B4	B5	B6	B7	B8	B9	H1	H2	H3	H4	D1	D2	D3		D4	D5	M	Net
UPS 32-30 F 220	6/10 220	-	110	135	141	-	75	75	-	80	110	110	68	245	312	104	32	76	90/100	140	14/19	M12	16.0	17.4	0.026
UPSD 32-30 F 220	6/10 220	103	52	-	141	360	180	180	100	200	-	-	68	245	313	-	32	76	90/100	140	14/19	M12	30.6	32.4	0.044

* Weights of bronze versions are approx. 10 % higher.

UPS 32-60 F 220, UPSD 32-60 F 220

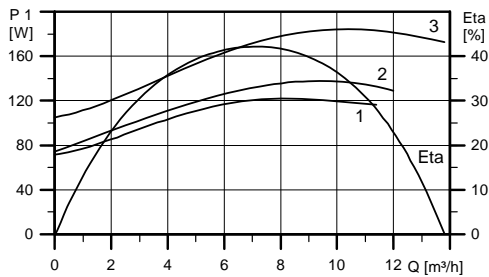
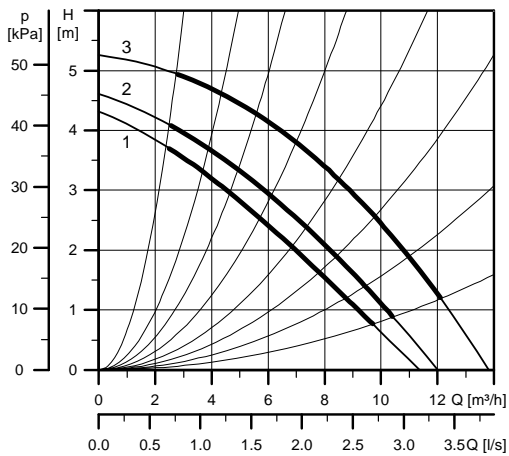

TMAO 9421 0497

Inlet pressure

t_m [°C]	75	90	120
H_{min} [bar]	0.05	0.2	1.5

Electrical data

		P_{max} [W]	P_{min} [W]	I1/I [A]	Cos ϕ
3 x 230 V	Speed 1	120	70	0.37	0.82
	Speed 2	140	75	0.40	0.88
	Speed 3	185	105	0.68	0.68
3 x 400-415 V	Speed 1	120	70	0.21	0.82
	Speed 2	140	75	0.23	0.88
	Speed 3	185	105	0.39	0.68

Series 200 is also available for 1 x 230-240 V.

Single-head pumps are available with bronze housing, type B.

Energy labelling

Pump type	Energy class	
	3 x 230 V	3 x 400-415 V
UPS 32-60 F 220	C	C
UPSD 32-60 F 220	C	C

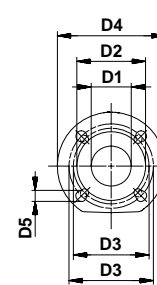
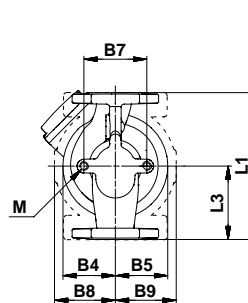
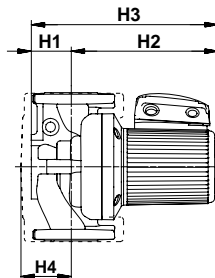
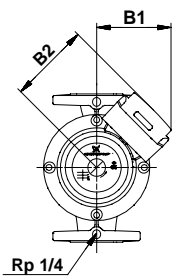

TM02 0701 3601

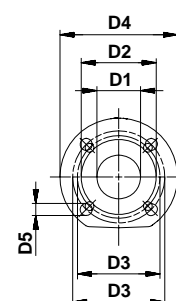
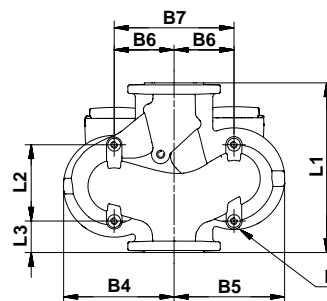
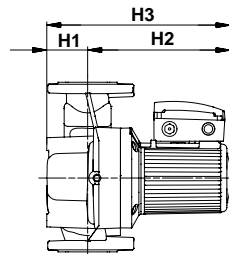
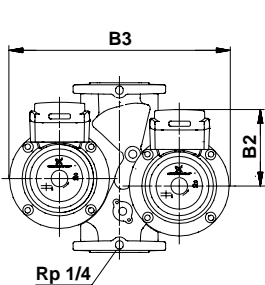

TM02 0703 3601

Dimensions and weights

Pump type	PN	Dimensions [mm]																	Weights [kg]*		Ship. vol. [m³]				
		L1	L2	L3	B1	B2	B3	B4	B5	B6	B7	B8	B9	H1	H2	H3	H4	D1	D2	D3		D4	D5	M	Net
UPS 32-60 F 220	6/10 220	-	110	135	141	-	75	75	-	80	110	110	68	242	310	103	32	76	90/100	140	14/19	M12	16.1	17.5	0.026
UPSD 32-60 F 220	6/10 220	103	52	-	141	360	180	180	100	200	-	-	68	242	310	-	32	76	90/100	140	14/19	M12	31.6	33.3	0.044

* Weights of bronze versions are approx. 10 % higher.

UPS 32-120 F 220, UPSD 32-120 F 220

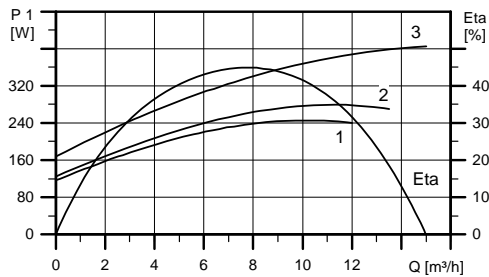
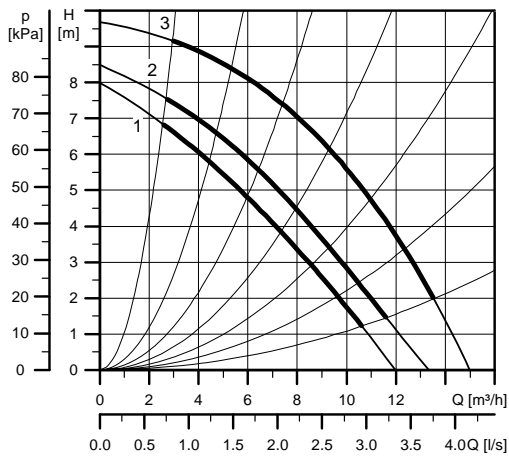

TMAO 9423 0497

Inlet pressure

t_m [°C]	75	90	120
H_{min} [bar]	0.4	0.7	1.95

Electrical data

		P_{max} [W]	P_{min} [W]	I1/I [A]	Cos ϕ
3 x 230 V	Speed 1	245	120	0.73	0.84
	Speed 2	280	130	0.82	0.86
	Speed 3	400	170	1.36	0.74
3 x 400-415 V	Speed 1	245	120	0.42	0.84
	Speed 2	280	130	0.47	0.86
	Speed 3	400	170	0.78	0.74

Series 200 is also available for 1 x 230-240 V.

Single-head pumps are available with bronze housing, type B.

Energy labelling

Pump type	Energy class	
	3 x 230 V	3 x 400-415 V
UPS 32-120 F 220	C	C
UPSD 32-120 F 220	D	D

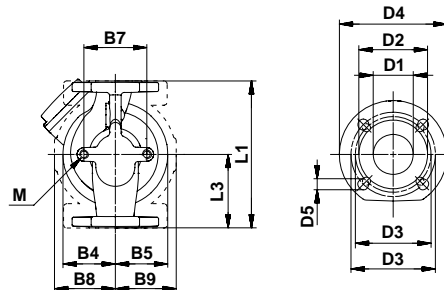
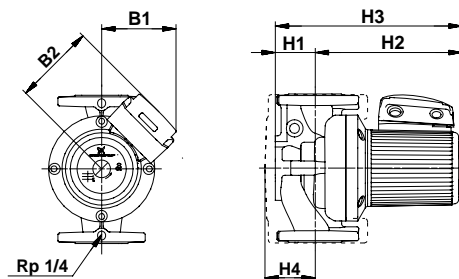

TM02 0701 3601

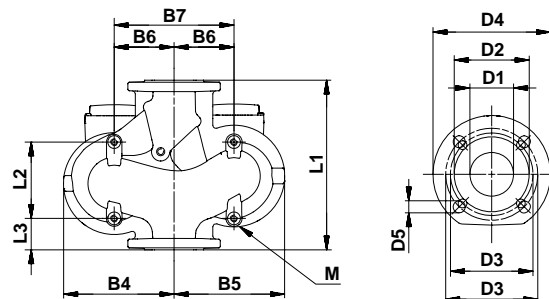
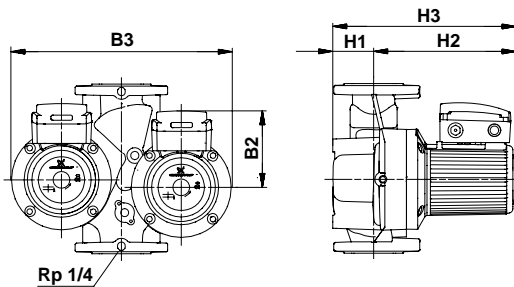

TM02 0703 3601

Dimensions and weights

Pump type	PN	Dimensions [mm]																		Weights [kg]*		Ship. vol. [m³]			
		L1	L2	L3	B1	B2	B3	B4	B5	B6	B7	B8	B9	H1	H2	H3	H4	D1	D2	D3	D4		D5	M	Net
UPS 32-120 F	6/10 220	-	110	135	141	-	75	75	-	80	110	110	68	242	310	103	32	76	90/100	140	14/19	M12	16.3	17.6	0.026
UPSD 32-120 F	6/10 220	103	52	-	141	360	180	180	100	200	-	-	68	243	311	-	32	76	90/100	140	14/19	M12	33.0	34.5	0.045

* Weights of bronze versions are approx. 10 % higher.

UPS 40-30 F 250, UPSD 40-30 F 250

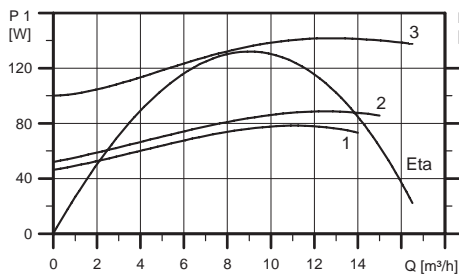
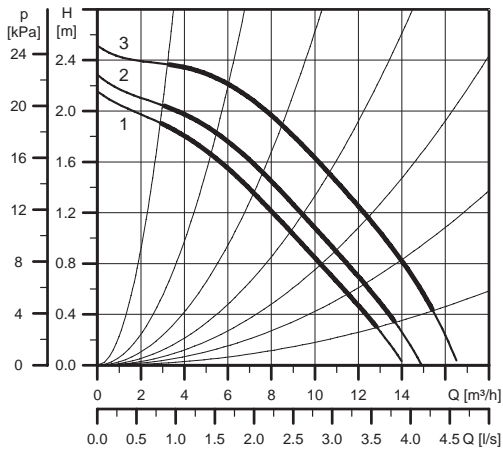

TMAO 9425 0497

Inlet pressure

t_m [°C]	75	90	120
H_{min} [bar]	0.05	0.15	1.45

Electrical data

		P_{max} [W]	P_{min} [W]	I1/I [A]	Cos ϕ
3 x 230 V	Speed 1	80	45	0.30	0.68
	Speed 2	90	50	0.35	0.65
	Speed 3	140	100	0.90	0.39
3 x 400-415 V	Speed 1	80	45	0.17	0.68
	Speed 2	90	50	0.20	0.65
	Speed 3	140	100	0.52	0.39

Series 200 is also available for 1 x 230-240 V

Single-head pumps are available with bronze housing, type B.

Energy labelling

Pump type	Energy class	
	3 x 230 V	3 x 400-415 V
UPS 40-30 F 250	C	C
UPSD 40-30 F 250	D	D

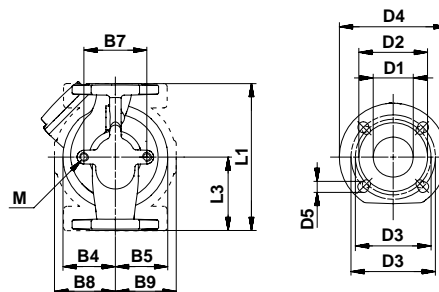
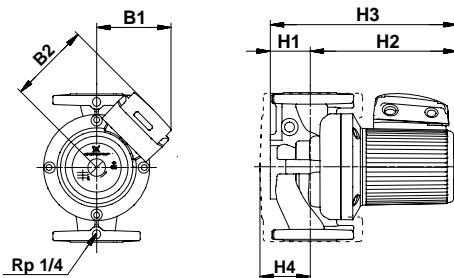

TM02 0701 3601

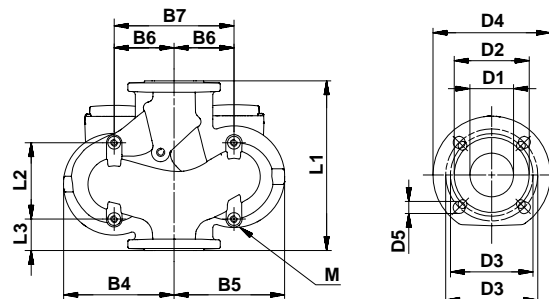
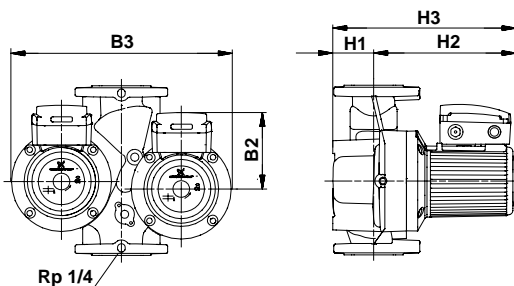

TM02 0703 3601

Dimensions and weights

Pump type	PN	Dimensions [mm]																	Weights [kg]*		Ship. vol. [m³]				
		L1	L2	L3	B1	B2	B3	B4	B5	B6	B7	B8	B9	H1	H2	H3	H4	D1	D2	D3		D4	D5	M	Net
UPS 40-30 F 250	6/10 250	-	125	135	141	-	85	75	-	120	118	110	68	249	317	108	40	84	100/110	150	14/19	M12	18.8	20.1	0.027
UPSD 40-30 F 250	6/10 250	126	45	-	141	360	180	180	100	200	-	-	68	249	317	-	40	84	100/110	150	14/19	M12	32.0	34.4	0.044

* Weights of bronze versions are approx. 10 % higher.

UPS 40-30 F 254

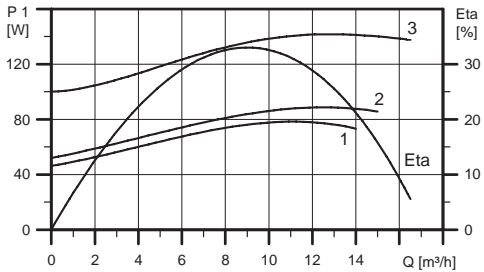
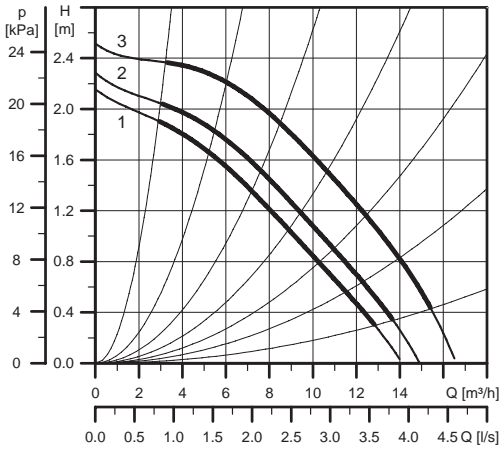

TMAO 9425 0497

Inlet pressure

t_m [°C]	75	90	120
H_{min} [bar]	0.05	0.15	1.45

Electrical data

	P_{max} [W]	P_{min} [W]	I1/I [A]	Cos ϕ	
3 x 400-415 V	Speed 1	80	45	0.17	0.68
	Speed 2	90	50	0.20	0.65
	Speed 3	140	100	0.52	0.39

Energy labelling

Pump type	Energy class
UPS 40-30 F 254	D

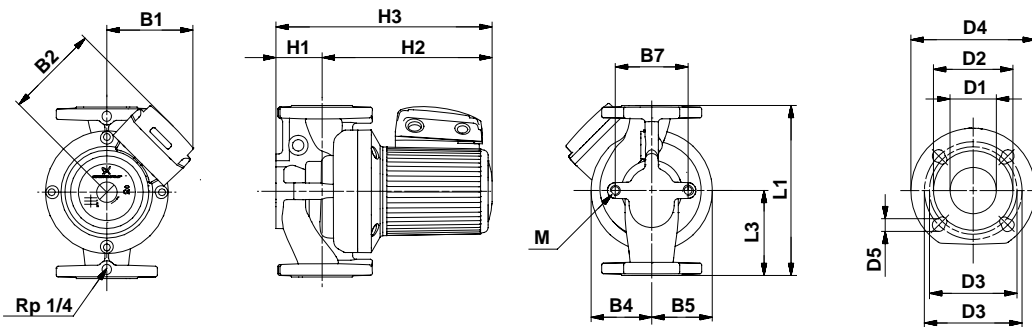

TMO3 2075 3605

Dimensions and weights

Pump type	PN	Dimensions [mm]																	Weights [kg]*		Ship. vol. [m³]				
		L1	L2	L3	B1	B2	B3	B4	B5	B6	B7	B8	B9	H1	H2	H3	H4	D1	D2	D3		D4	D5	M	Net
UPS 40-30 F 254	6/10 254	-	127	135	141	-	85	75	-	120	118	110	68	249	317	-	40	84	100/110	150	14/19	M12	18.8	20.1	0.027

UPS 40-60/4 F 250

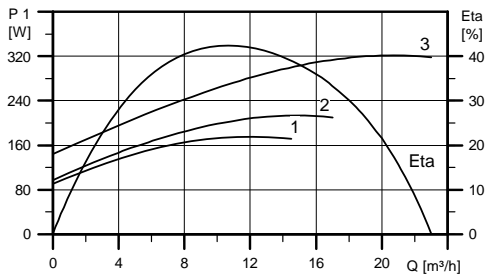
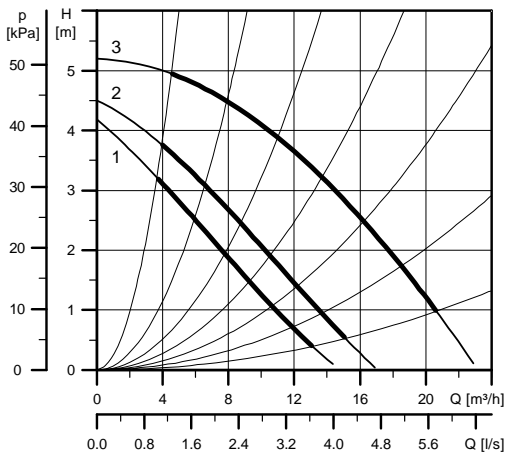

TMAO 9427 0497

Inlet pressure

t_m [°C]	75	90	120
H_{min} [bar]	0.05	0.05	1.3

Electrical data

	P_{max} [W]	P_{min} [W]	I1/I [A]	Cos ϕ	
3 x 230 V	Speed 1	175	90	0.56	0.79
	Speed 2	215	100	0.66	0.82
	Speed 3	320	145	1.15	0.70
3 x 400-415 V	Speed 1	175	90	0.32	0.79
	Speed 2	215	100	0.38	0.82
	Speed 3	320	145	0.66	0.70

Series 200 is also available for 1 x 230-240 V

Single-head pumps are available with bronze housing, type B.

Energy labelling

Pump type	Energy class	
	3 x 230 V	3 x 400-415 V
UPS 40-60/4 F 250	C	C

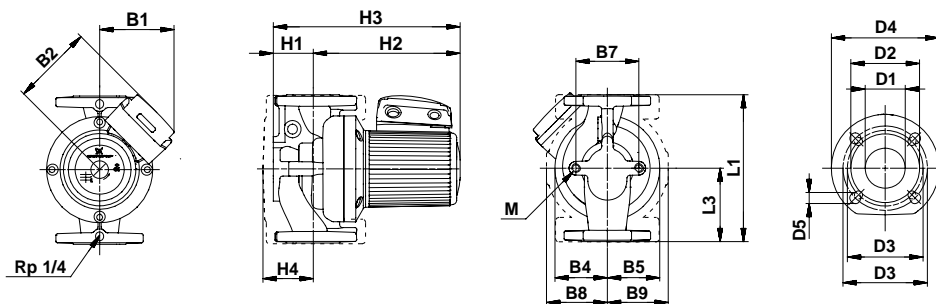

TMO2 0701 3601

Dimensions and weights

Pump type	PN	Dimensions [mm]																	Weights [kg]*		Ship. vol. [m³]				
		L1	L2	L3	B1	B2	B3	B4	B5	B6	B7	B8	B9	H1	H2	H3	H4	D1	D2	D3		D4	D5	M	Net
UPS 40-60/4 F 250	6/10 250	-	125	135	141	-	100	100	-	120	134	134	75	231	306	115	40	84	100/110	150	14/19	M12	20.8	22.4	0.034

* Weights of bronze versions are approx. 10% higher.

UPS 40-60/2 F 220

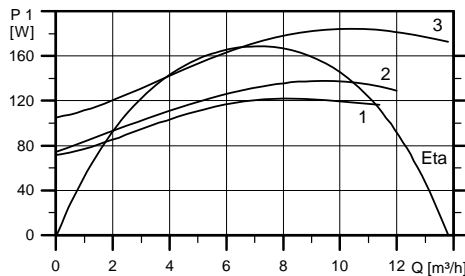
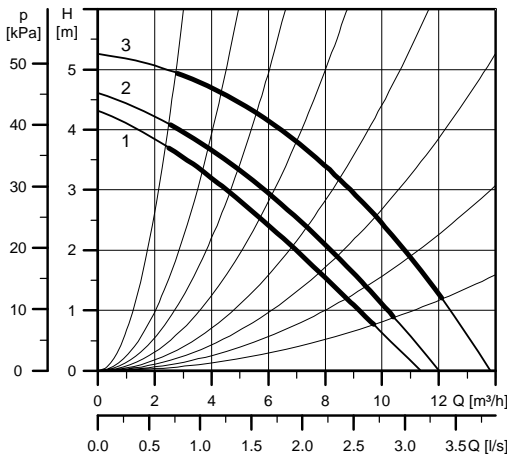

TMAO 9421 0497

Inlet pressure

t_m [°C]	75	90	120
H_{min} [bar]	0.15	0.45	1.75

Electrical data

	P_{max} [W]	P_{min} [W]	I1/I [A]	Cos ϕ	
3 x 400-415 V	Speed 1	120	70	0.21	0.82
	Speed 2	140	75	0.23	0.88
	Speed 3	185	105	0.39	0.68

Energy labelling

Pump type	Energy class
UPS 40-60/2 F 220	C

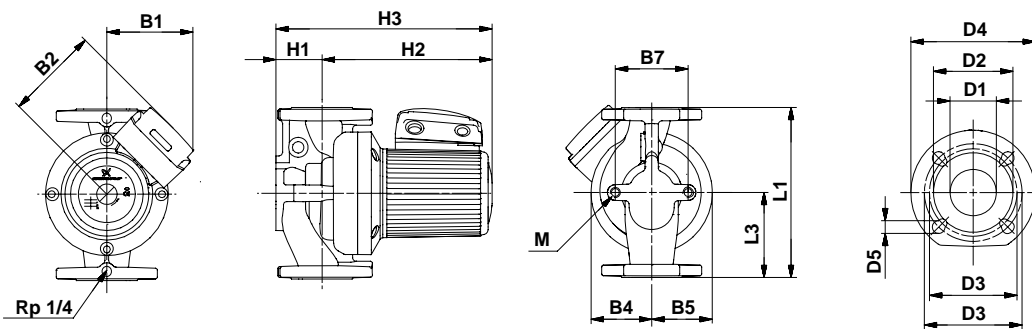

TMO3 2075 3605

Dimensions and weights

Pump type	PN	Dimensions [mm]																	Weights [kg]*		Ship. vol. [m³]				
		L1	L2	L3	B1	B2	B3	B4	B5	B6	B7	B8	B9	H1	H2	H3	H4	D1	D2	D3		D4	D5	M	Net
UPS 40-60/2 F 220	6/10 220	-	110	135	141	-	75	75	-	80	-	-	68	242	310	-	40	84	100/110	150	14/19	M12	18.3	19.6	0.027

UPS 40-60/2 F 250, UPSD 40-60/2 F 250

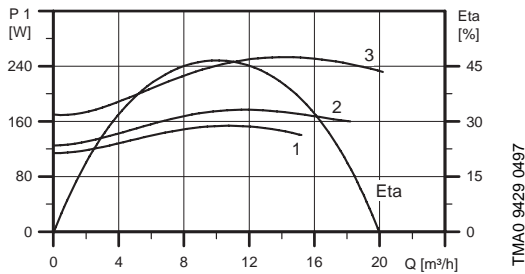
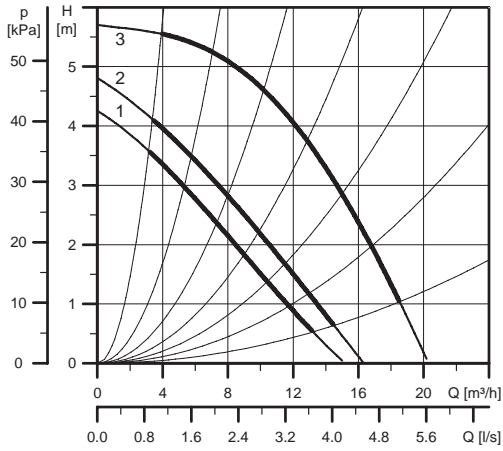

Inlet pressure

t_m [°C]	75	90	120
H_{min} [bar]	0.15	0.45	1.75

Electrical data

	P_{max} [W]	P_{min} [W]	I1/1 [A]	Cos ϕ	
3 x 230 V	Speed 1	155	115	0.43	0.89
	Speed 2	175	125	0.50	0.87
	Speed 3	250	170	0.80	0.78
3 x 400-415 V	Speed 1	155	115	0.25	0.89
	Speed 2	175	125	0.29	0.87
	Speed 3	250	170	0.46	0.78

Series 200 is also available for 1 x 230-240 V

Single-head pumps are available with bronze housing, type B.

Energy labelling

Pump type	Energy class	
	3 x 230 V	3 x 400-415 V
UPS 40-60/2 F 250	C	C
UPSD 40-60/2 F 250	D	D

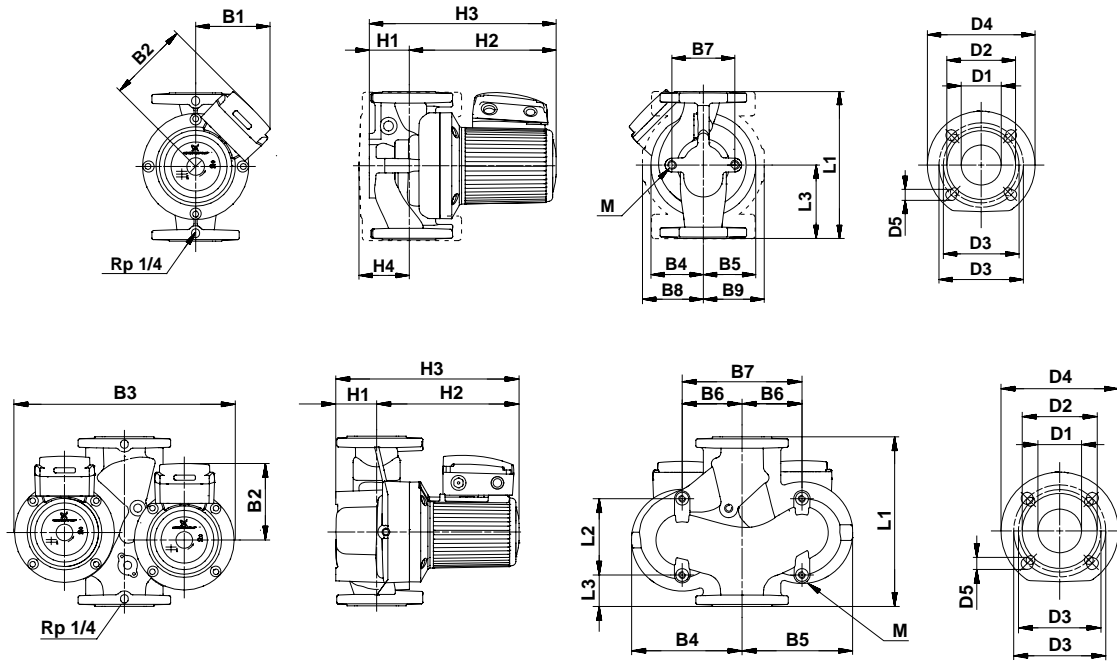

TM02 0701 3601

TM02 0703 3601

Dimensions and weights

Pump type	PN	Dimensions [mm]																		Weights [kg]*		Ship. vol. [m³]			
		L1	L2	L3	B1	B2	B3	B4	B5	B6	B7	B8	B9	H1	H2	H3	H4	D1	D2	D3	D4		D5	M	Net
UPS 40-60/2 F 250	6/10 250	-	125	135	141	-	75	75	-	80	110	110	68	248	316	103	40	84	100/110	150	14/19	M12	16.6	17.9	0.026
UPSD 40-60/2 F 250	6/10 250	125	45	-	141	360	180	180	100	200	-	-	68	246	314	-	40	84	100/110	150	14/19	M12	32.6	35.6	0.044

* Weights of bronze versions are approx. 10 % higher.

UPS 40-120 F 250, UPSD 40-120 F 250

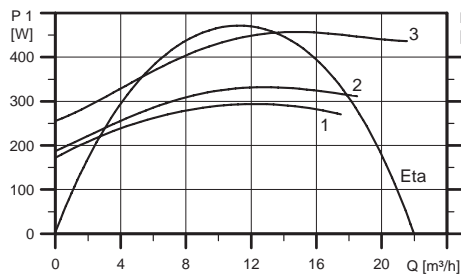
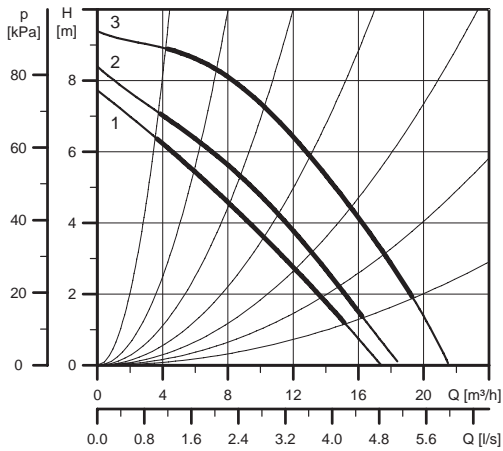

TMAO 9431 0497

Inlet pressure

t_m [°C]	75	90	120
H_{min} [bar]	0.1	0.4	1.7

Electrical data

		P_{max} [W]	P_{min} [W]	I1/1 [A]	Cos ϕ
3 x 230 V	Speed 1	290	175	0.85	0.85
	Speed 2	330	190	0.97	0.85
	Speed 3	460	260	1.60	0.72
3 x 400-415 V	Speed 1	290	175	0.49	0.85
	Speed 2	330	190	0.56	0.85
	Speed 3	460	260	0.92	0.72

Series 200 is also available for 1 x 230-240 V

Single-head pumps are available with bronze housing, type B.

Energy labelling

Pump type	Energy class	
	3 x 230 V	3 x 400-415 V
UPS 40-120 F 250	C	C
UPSD 40-120 F 250	D	D

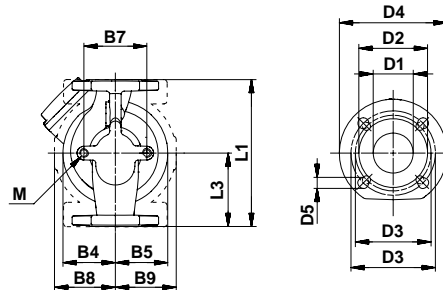
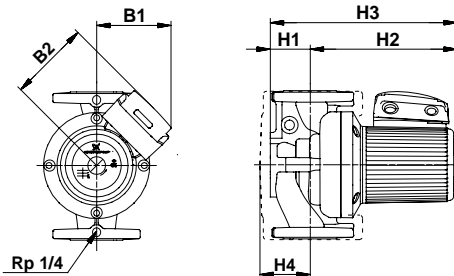

TM02 0701 3601

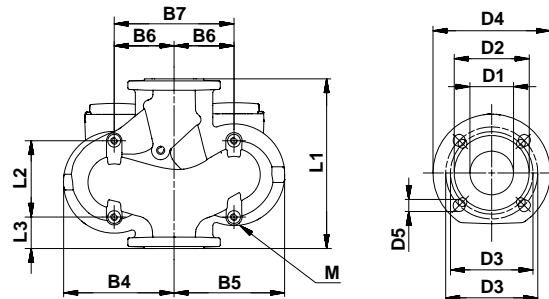
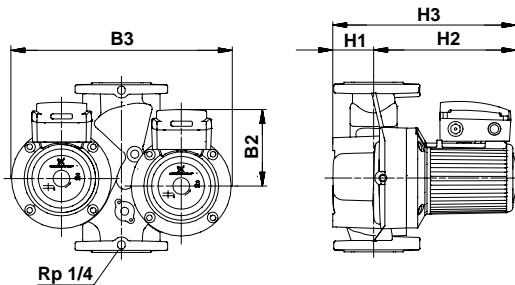

TM02 0703 3601

Dimensions and weights

Pump type	PN	Dimensions [mm]																			Weights [kg]*		Ship. vol. [m³]		
		L1	L2	L3	B1	B2	B3	B4	B5	B6	B7	B8	B9	H1	H2	H3	H4	D1	D2	D3	D4	D5		M	Net
UPS 40-120 F 250	6/10 250	-	125	135	141	-	75	75	-	80	110	110	68	246	314	103	40	84	100/110	150	14/19	M12	17.7	19.2	0.026
UPSD 40-120 F 250	6/10 250	125	45	-	141	360	180	180	100	200	-	-	68	245	313	-	40	84	100/110	150	14/19	M12	33.0	37.7	0.044

* Weights of bronze versions are approx. 10 % higher.

UPS 40-180 F 250

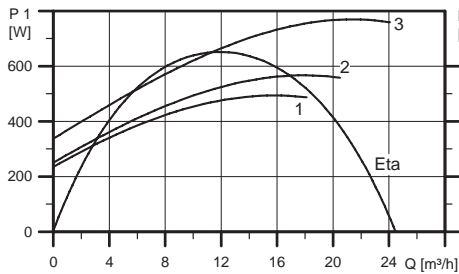
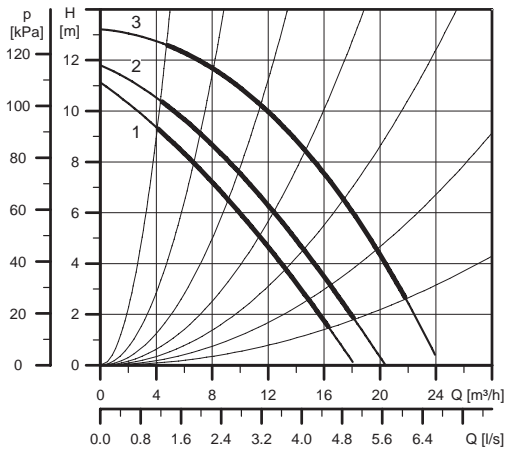

TMAO 9433 0497

Inlet pressure

t_m [°C]	75	90	120
H_{min} [bar]	0.4	0.7	1.95

Electrical data

		P_{max} [W]	P_{min} [W]	I1/1 [A]	Cos ϕ
3 x 230 V	Speed 1	490	235	1.43	0.86
	Speed 2	570	250	1.63	0.86
	Speed 3	770	350	2.26	0.85
3 x 400-415 V	Speed 1	490	235	0.82	0.86
	Speed 2	570	250	0.94	0.86
	Speed 3	770	350	1.30	0.85

Series 200 is also available for 1 x 230-240 V

Single-head pumps are available with bronze housing, type B.

Energy labelling

Pump type	Energy class	
	3 x 230 V	3 x 400-415 V
UPS 40-180 F 250	C	C

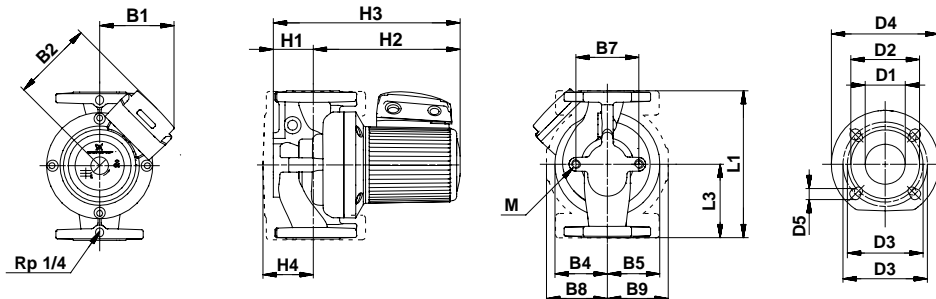

TM02 0701 3601

Dimensions and weights

Pump type	PN	Dimensions [mm]																	Weights [kg]*		Ship. vol. [m³]				
		L1	L2	L3	B1	B2	B3	B4	B5	B6	B7	B8	B9	H1	H2	H3	H4	D1	D2	D3		D4	D5	M	Net
UPS 40-180 F 250	6/10 250	-	125	145	169	-	100	100	-	80	134	134	68	240	308	106	40	84	100/110	150	14/19	M12	21.4	22.8	0.034

* Weights of bronze versions are approx. 10% higher.

UPS 40-185 F 250

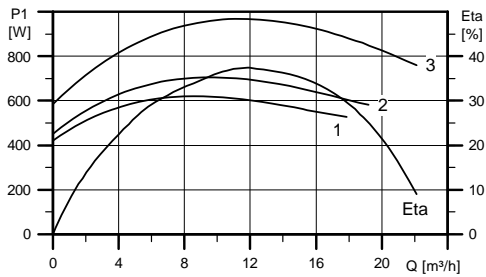
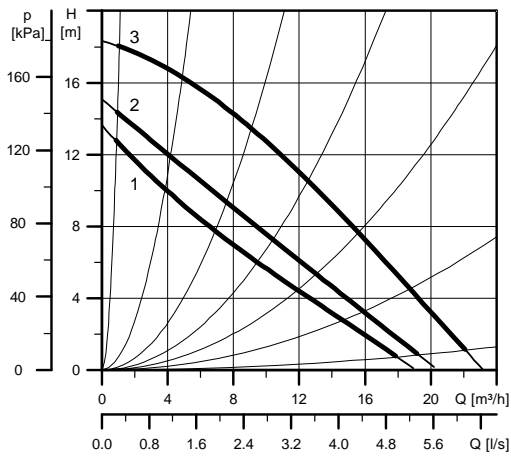

Inlet pressure

t_m [°C]	70	90	120
H_{min} [bar]	0.55	0.90	1.8

Electrical data

	P_{max} [W]	P_{min} [W]	I1/I [A]	Cos ϕ	
3 x 400-415 V	Speed 1	620	415	1.04	0.86
	Speed 2	705	450	1.18	0.86
	Speed 3	975	580	1.80	0.78

Series 200 is also available for 1 x 230-240 V

Energy labelling

Pump type	Energy class	
	3 x 230 V	3 x 400-415 V
UPS 40-185 F 250	C	C

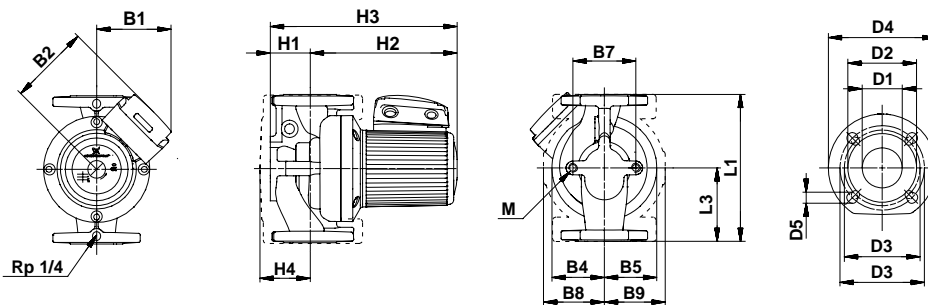

TM02 0701 3601

Dimensions and weights

Pump type	PN	Dimensions [mm]																			Weights [kg]		Ship. vol. [m³]			
		L1	L2	L3	B1	B2	B3	B4	B5	B6	B7	B8	B9	H1	H2	H3	H4	D1	D2	D3	D4	D5		M	Net	Gross
UPS 40-185 F 250	6/10	250	-	125	142	155	-	100	102	-	96	-	-	67	243	310	-	42	88	100/110	150	14/19	M12	19.7	21.4	0.034

UPS 50-30 F 280, UPSD 50-30 F 280

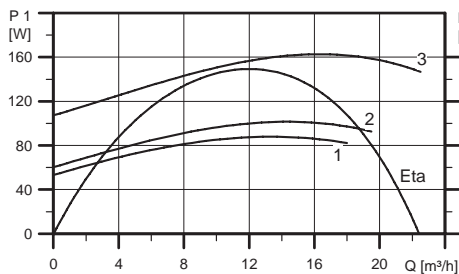
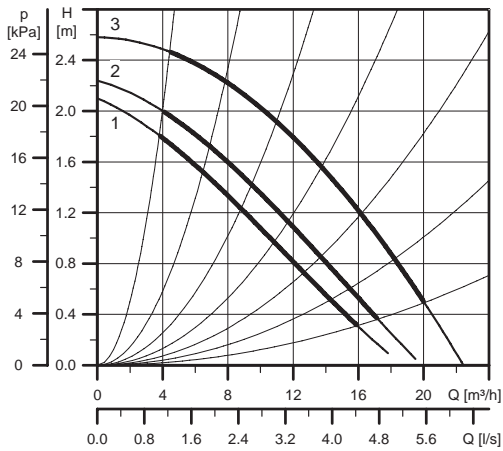

TMAO 9435 0497

Inlet pressure

t_m [°C]	75	90	120
H_{min} [bar]	1.85	1.0	2.15

Electrical data

		P_{max} [W]	P_{min} [W]	I1/I [A]	Cos ϕ
3 x 230 V	Speed 1	90	55	0.37	0.62
	Speed 2	100	60	0.38	0.66
	Speed 3	160	105	0.90	0.44
3 x 400-415 V	Speed 1	90	55	0.21	0.62
	Speed 2	100	60	0.22	0.66
	Speed 3	160	105	0.52	0.44

Series 200 is also available for 1 x 230-240 V.

Single-head pumps are available with bronze housing, type B.

Energy labelling

Pump type	Energy class	
	3 x 230 V	3 x 400-415 V
UPS 50-30 F 280	C	C
UPSD 50-30 F 280	D	D

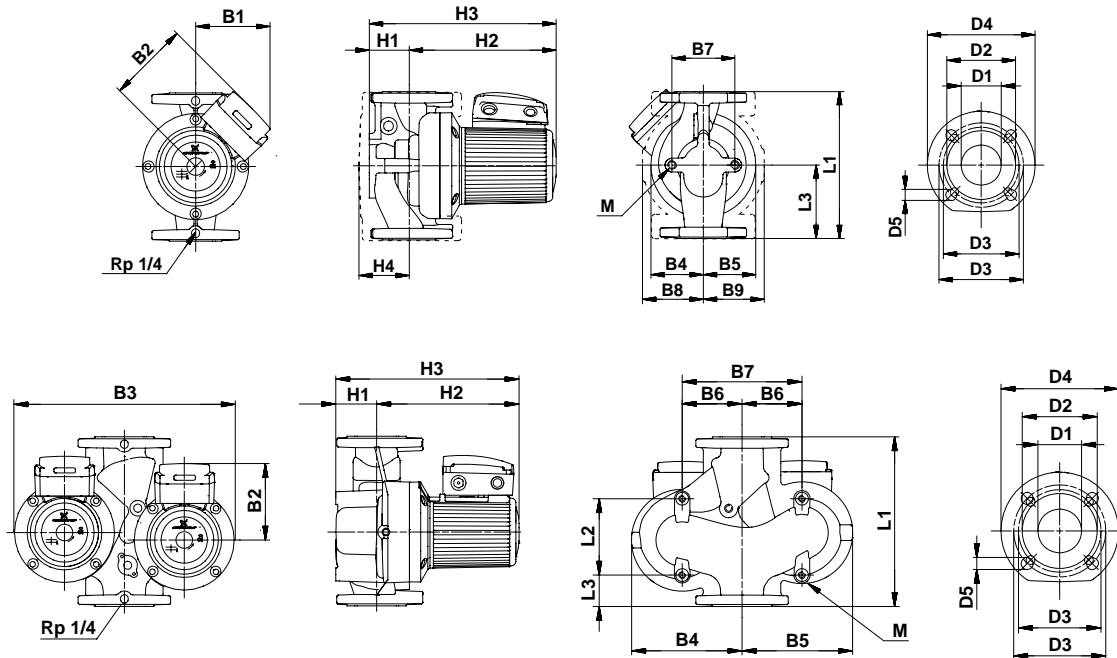

TM02 0701 3601

TM02 0703 3601

Dimensions and weights

Pump type	PN	Dimensions [mm]																	Weights [kg]*		Ship. vol. [m³]				
		L1	L2	L3	B1	B2	B3	B4	B5	B6	B7	B8	B9	H1	H2	H3	H4	D1	D2	D3		D4	D5	M	Net
UPS 50-30 F 280	6/10 280	-	140	135	141	-	90	75	-	120	122	111	82	251	333	123	50	99	110/125	165	14/19	M12	20.7	22.3	0.034
UPSD 50-30 F 280	6/10 280	125	60	-	141	360	190	185	100	200	-	-	90	251	341	-	50	99	110/125	165	14/19	M12	37.0	40.1	0.061

* Weights of bronze versions are approx. 10 % higher.

UPS 50-60/4 F 280, UPSD 50-60/4 F 280

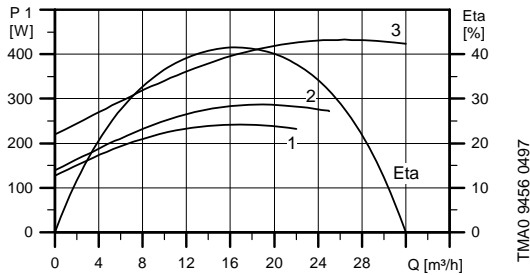
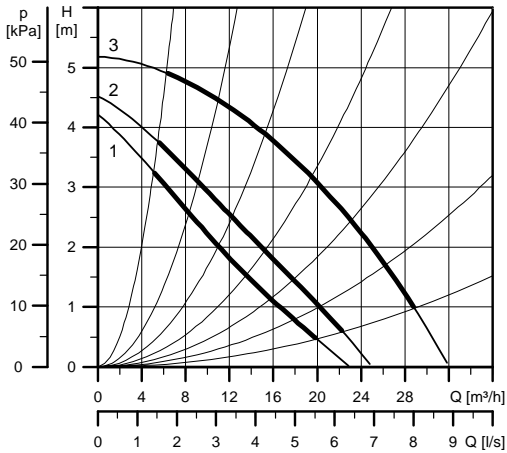

Inlet pressure

t_m [°C]	75	90	120
H_{min} [bar]	0.05	0.15	1.45

Electrical data

	P_{max} [W]	P_{min} [W]	I1/I [A]	Cos ϕ	
3 x 230 V	Speed 1	240	130	0.75	0.81
	Speed 2	290	140	0.87	0.84
	Speed 3	430	220	1.60	0.67
3 x 400-415 V	Speed 1	240	130	0.43	0.81
	Speed 2	290	140	0.50	0.84
	Speed 3	430	220	0.92	0.67

Series 200 is also available for 1 x 230-240 V

Single-head pumps are available with bronze housing, type B.

Energy labelling

Pump type	Energy class	
	3 x 230 V	3 x 400-415 V
UPS 50-60/4 F 280	C	C
UPSD 50-60/4 F 280	D	D

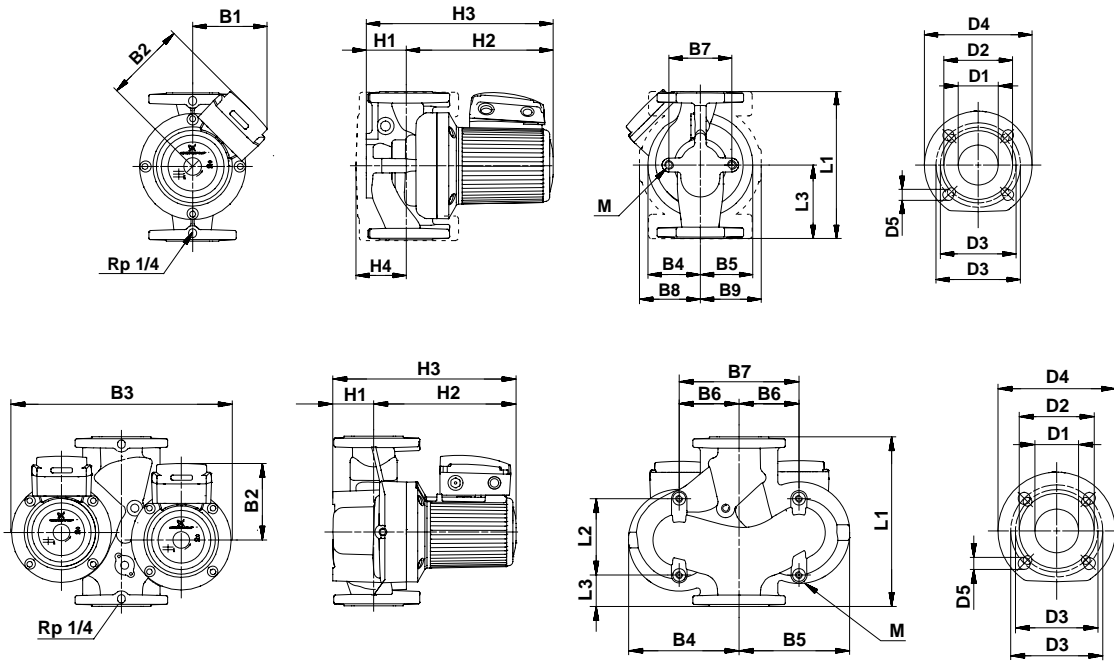

Dimensions and weights

Pump type	PN	Dimensions [mm]																	Weights [kg]*		Ship. vol. [m³]				
		L1	L2	L3	B1	B2	B3	B4	B5	B6	B7	B8	B9	H1	H2	H3	H4	D1	D2	D3		D4	D5	M	Net
UPS 50-60/4 F 280	6/10 280	-	140	135	141	-	110	100	-	120	135	135	82	236	318	120	50	99	110/125	165	14/19	M12	23.1	24.4	0.034
UPSD 50-60/4 F 280	6/10 280	126	60	-	169	450	225	225	120	240	-	-	82	236	318	-	50	102	110/125	165	14/19	M12	48.0	51.0	0.061

* Weights of bronze versions are approx. 10 % higher.

UPS 50-60/2 F 280, UPSD 50-60/2 F 280

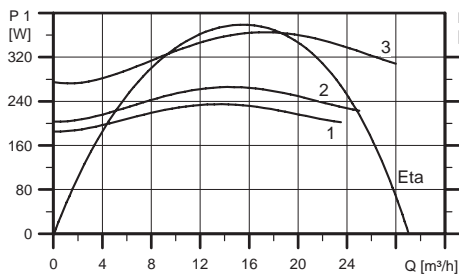
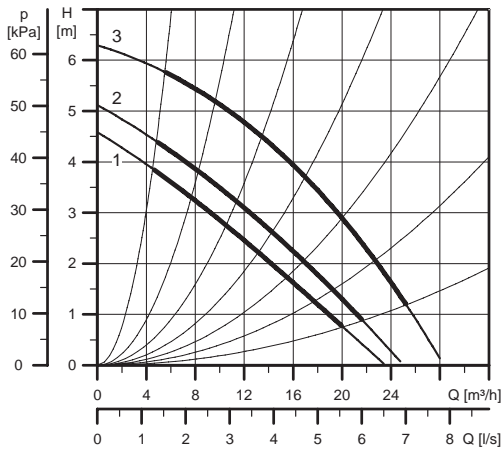

Inlet pressure

t_m [°C]	75	90	120
H_{min} [bar]	0.05	0.35	1.65

Electrical data

		P_{max} [W]	P_{min} [W]	I1/1 [A]	Cos ϕ
3 x 230 V	Speed 1	235	185	0.68	0.87
	Speed 2	270	205	0.78	0.87
	Speed 3	360	270	1.29	0.70
3 x 400-415 V	Speed 1	235	185	0.39	0.87
	Speed 2	270	205	0.45	0.87
	Speed 3	360	270	0.74	0.70

Series 200 is also available for 1 x 230-240 V

Single-head pumps are available with bronze housing, type B.

Energy labelling

Pump type	Energy class	
	3 x 230 V	3 x 400-415 V
UPS 50-60/2 F 280	C	C
UPSD 50-60/2 F 280	D	D

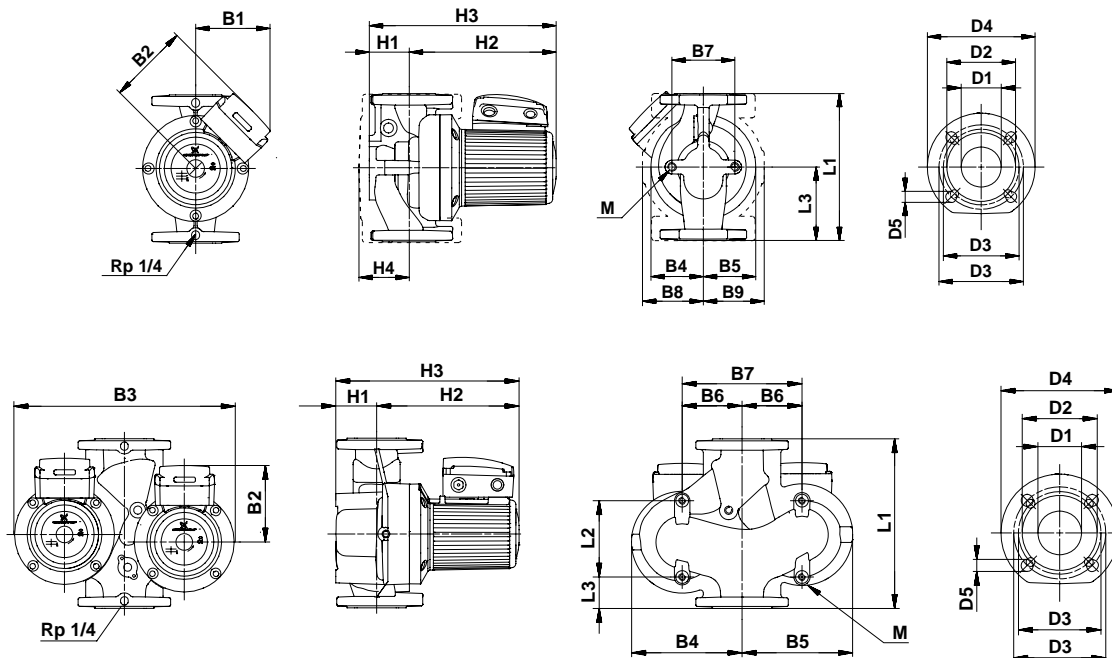

TM02 0701 3601

TM02 0703 3601

Dimensions and weights

Pump type	PN	Dimensions [mm]																	Weights [kg]*		Ship. vol. [m³]				
		L1	L2	L3	B1	B2	B3	B4	B5	B6	B7	B8	B9	H1	H2	H3	H4	D1	D2	D3		D4	D5	M	Net
UPS 50-60/2 F 280	6/10 280	-	140	135	141	-	90	75	-	120	122	111	75	253	328	123	50	99	110/125	165	14/19	M12	27.7	29.3	0.043
UPSD 50-60/2 F 280	6/10 280	125	60	-	141	370	190	180	100	200	-	-	75	254	329	-	50	99	110/125	165	14/19	M12	38.7	41.1	0.061

* Weights of bronze versions are approx. 10 % higher.

UPS 50-60/2 F 300

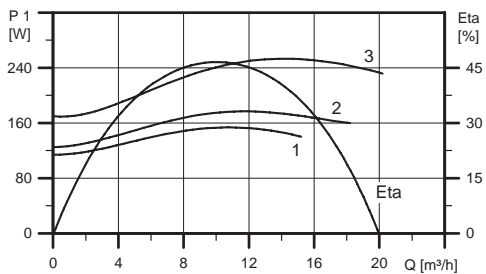
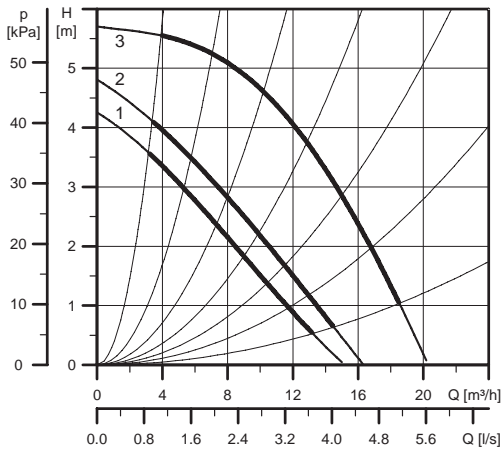

TM0A 9429 0497

Inlet pressure

t_m [°C]	75	90	120
H_{min} [bar]	0.05	0.35	1.65

Electrical data

	P_{max} [W]	P_{min} [W]	I1/I [A]	Cos ϕ	
3 x 400-415 V	Speed 1	155	115	0.25	0.89
	Speed 2	175	125	0.29	0.87
	Speed 3	250	170	0.46	0.78

Energy labelling

Pump type	Energy class
UPS 50-60/2 F 300	3 x 400-415 V C

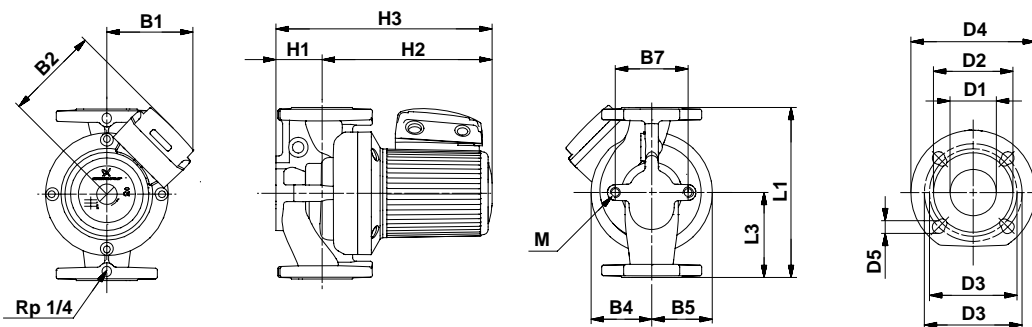

TM03 2075 3605

Dimensions and weights

Pump type	PN	Dimensions [mm]																	Weights [kg]*		Ship. vol. [m³]				
		L1	L2	L3	B1	B2	B3	B4	B5	B6	B7	B8	B9	H1	H2	H3	H4	D1	D2	D3		D4	D5	M	Net
UPS 50-60/2 F 300	6/10 300	-	150	135	141	-	75	75	-	80	-	-	68	248	316	-	50	99	110/125	165	14/19	M12	21.8	23.4	0.034

UPS 50-120 F 280, UPSD 50-120 F 280

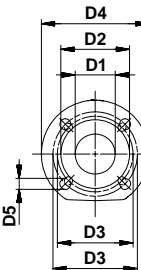
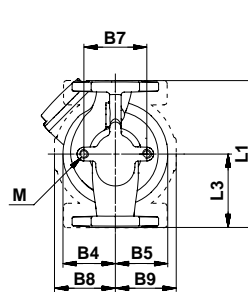
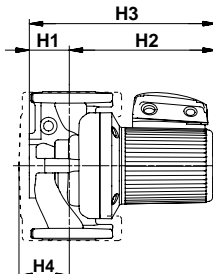
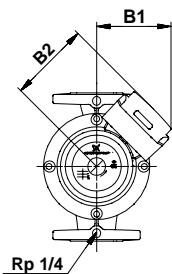
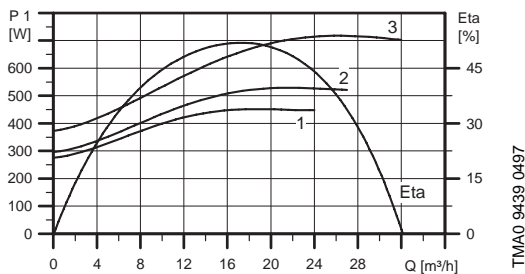
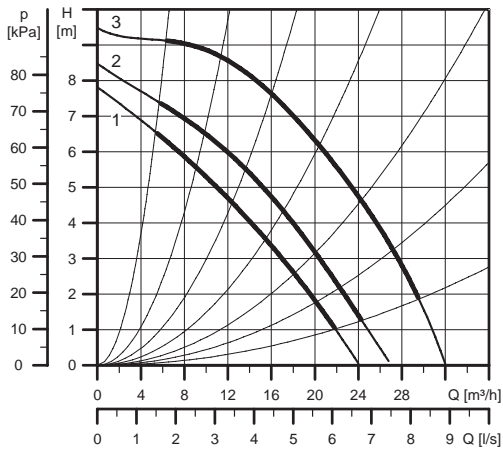

TM02 0701 3601

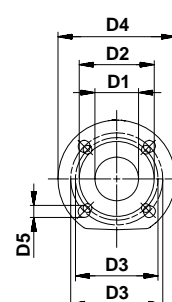
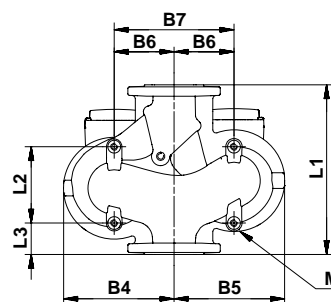
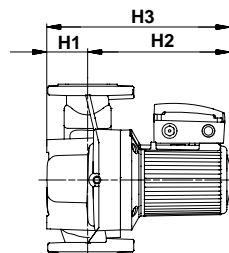
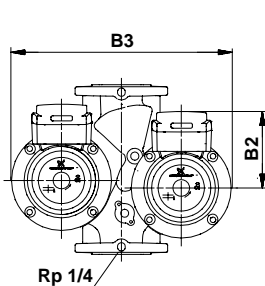

TM02 0703 3601

Inlet pressure

t_m [°C]	75	90	120
H_{min} [bar]	0.4	0.7	1.95

Electrical data

		P_{max} [W]	P_{min} [W]	I1/I [A]	Cos ϕ
3 x 230 V	Speed 1	450	280	1.43	0.79
	Speed 2	530	300	1.63	0.81
	Speed 3	720	380	2.26	0.80
3 x 400-415 V	Speed 1	450	280	0.82	0.79
	Speed 2	530	300	0.94	0.81
	Speed 3	720	380	1.30	0.80

Series 200 is also available for 1 x 230-240 V.

Single-head pumps are available with bronze housing, type B.

Energy labelling

Pump type	Energy class	
	3 x 230 V	3 x 400-415 V
UPS 50-120 F 280	C	C
UPSD 50-120 F 280	C	C

Dimensions and weights

Pump type	PN	Dimensions [mm]																	Weights [kg]*		Ship. vol. [m ³]				
		L1	L2	L3	B1	B2	B3	B4	B5	B6	B6	B8	B9	H1	H2	H3	H4	D1	D2	D3		D4	D5	M	Net
UPS 50-120 F 280	6/10 280	-	140	145	169	-	100	100	-	120	135	135	75	232	307	116	50	99	110/125	165	14/19	M12	24.3	25.4	0.034
UPSD 50-120 F 280	6/10 280	126	60	-	169	450	225	225	120	240	-	-	75	231	306	-	50	99	110/125	165	14/19	M12	46.1	48.1	0.061

* Weights of bronze versions are approx. 10 % higher.

UPS 50-180 F 280, UPSD 50-180 F 280

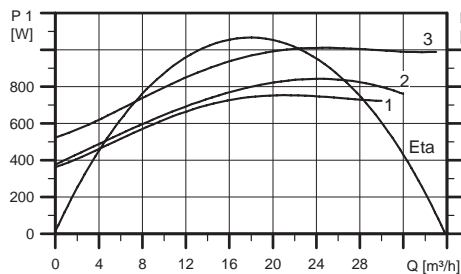
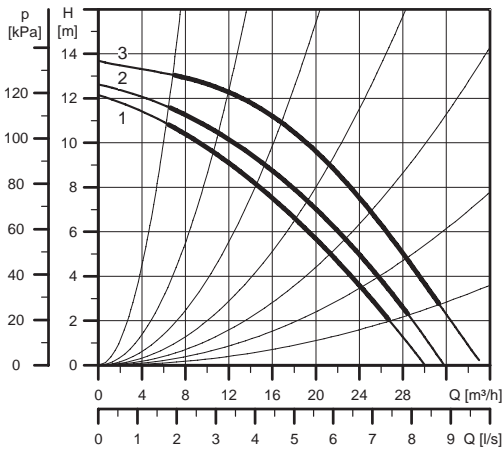

TMA0 9441 0497

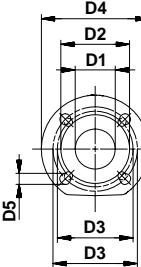
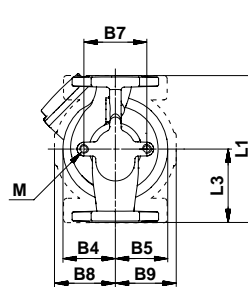
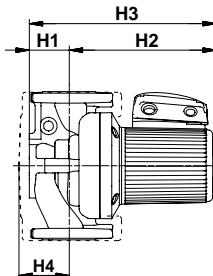
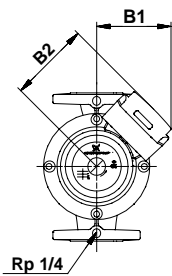

TM02 0701 3601

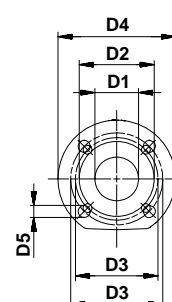
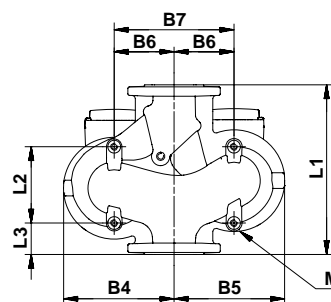
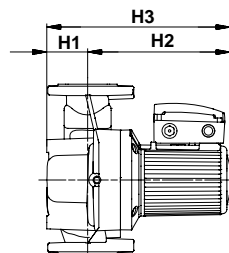
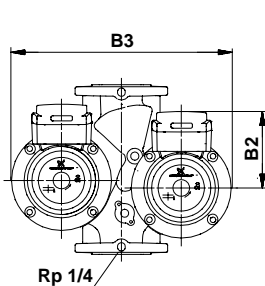

TM02 0703 3601

Inlet pressure

t_m [°C]	75	90	120
H_{min} [bar]	0.35	0.65	1.9

Electrical data

		P_{max} [W]	P_{min} [W]	I1/1 [A]	Cos ϕ
3 x 230 V	Speed 1	760	360	2.17	0.88
	Speed 2	850	380	2.43	0.88
	Speed 3	1000	520	3.48	0.72
3 x 400-415 V	Speed 1	760	360	1.25	0.88
	Speed 2	850	380	1.40	0.88
	Speed 3	1000	520	2.00	0.72

Series 200 is also available for 1 x 230-240 V

Single-head pumps are available with bronze housing, type B.

Energy labelling

Pump type	Energy class	
	3 x 230 V	3 x 400-415 V
UPS 50-180 F 280	C	C
UPSD 50-180 F 280	C	C

Dimensions and weights

Pump type	PN	Dimensions [mm]																	Weights [kg]*		Ship. vol. [m ³]				
		L1	L2	L3	B1	B2	B3	B4	B5	B6	B6	B8	B9	H1	H2	H3	H4	D1	D2	D3		D4	D5	M	Net
UPS 50-180 F 280	6/10 280	-	140	145	169	-	100	100	-	120	135	135	75	276	351	116	50	99	110/125	165	14/19	M12	25.6	26.9	0.043
UPSD 50-180 F 280	6/10 280	126	60	-	169	450	225	225	120	240	-	-	75	276	351	-	50	99	110/125	165	14/19	M12	51.5	58.4	0.125

* Weights of bronze versions are approx. 10 % higher.

UPS 50-185 F 280

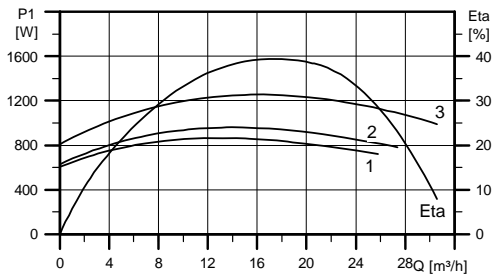
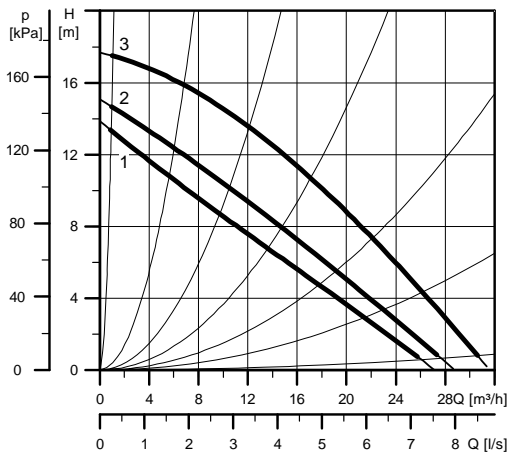

TMA1 4943 1199

Inlet pressure

t_m [°C]	75	90	120
H_{min} [bar]	1.85	1.0	2.15

Electrical data

	P_{max} [W]	P_{min} [W]	I1/I [A]	Cos ϕ	
3 x 400-415 V	Speed 1	1150	710	5.60	0.89
	Speed 2	1240	770	6.05	0.89
	Speed 3	1290	810	6.00	0.93

Series 200 is also available for 1 x 230-240 V

Energy labelling

Pump type	Energy class
UPS 50-185 F 280	D

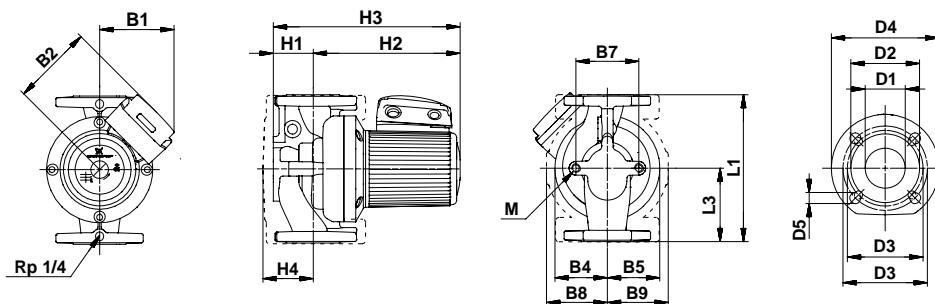

TM02 0701 3601

Dimensions and weights

Pump type	PN	Dimensions [mm]																	Weights [kg]		Ship. vol. [m ³]					
		L1	L2	L3	B1	B2	B3	B4	B5	B6	B6	B8	B9	H1	H2	H3	H4	D1	D2	D3		D4	D5	M	Net	Gross
UPS 50-185 F 280	6/10	280	-	140	145	155	-	91	104	-	96	-	-	75	274	349	-	50	99	110/125	165	14/19	M12	25.6	26.9	0.043

UPS 65-30 F 340, UPSD 65-30 F 340

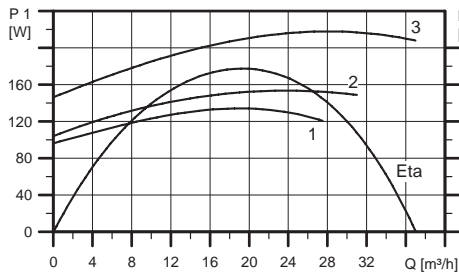
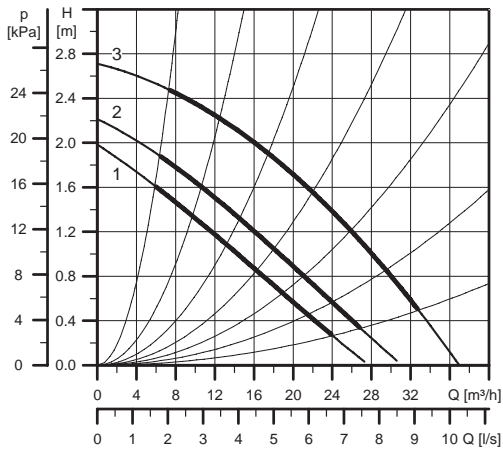

TMA0 9443 0497

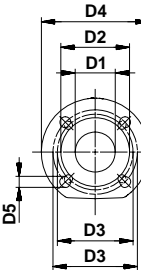
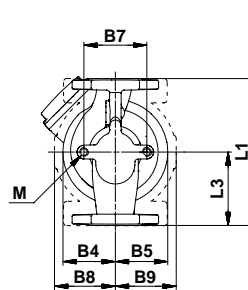
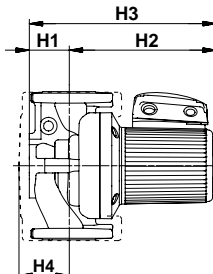
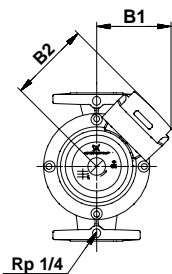

TM02 0701 3601

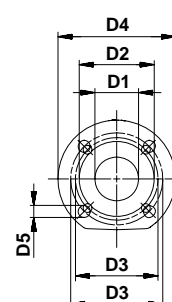
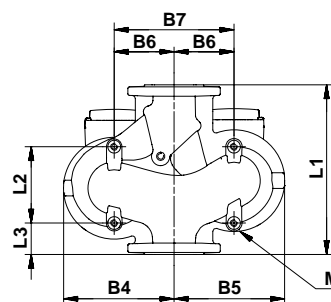
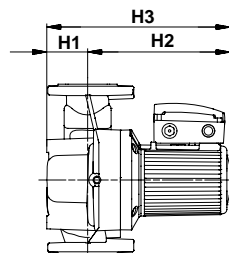
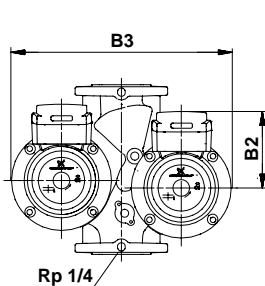

TM02 0703 3601

Inlet pressure

t_m [°C]	75	90	120
H_{min} [bar]	0.4	0.7	1.95

Electrical data

	P_{max} [W]	P_{min} [W]	I1/1 [A]	Cos ϕ	
3 x 230 V	Speed 1	135	95	0.42	0.81
	Speed 2	155	105	0.49	0.80
	Speed 3	215	145	0.90	0.60
3 x 400-415 V	Speed 1	135	95	0.24	0.81
	Speed 2	155	105	0.28	0.80
	Speed 3	215	145	0.52	0.60

Series 200 is also available for 1 x 230-240 V

Single-head pumps are available with bronze housing, type B.

Energy labelling

Pump type	Energy class	
	3 x 230 V	3 x 400-415 V
UPS 65-30 F 340	C	C
UPSD 65-30 F 340	D	D

Dimensions and weights

Pump type	PN	Dimensions [mm]																				Weights [kg]*		Ship. vol. [m ³]	
		L1	L2	L3	B1	B2	B3	B4	B5	B6	B7	B8	B9	H1	H2	H3	H4	D1	D2	D3	D4	D5	M		Net
UPS 65-30 F 340	6/10 340	-	170	145	169	-	125	100	-	160	156	140	97	244	341	145	65	118	130/145	185	14/19	M16	29.3	31.2	0.055
UPSD 65-30 F 340	6/10 340	153	63	-	169	470	230	240	120	240	-	-	97	243	340	-	65	118	130/145	185	14/19	M12	56.5	65.1	0.125

* Weights of bronze versions are approx. 10 % higher.

UPS 65-60/4 F 340, UPSD 65-60/4 F 340

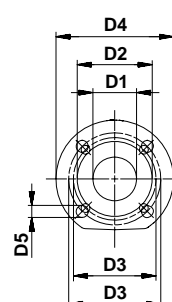
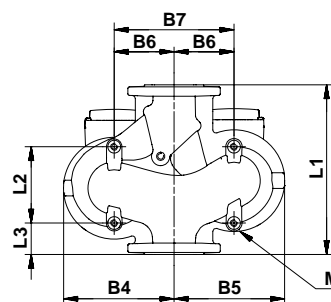
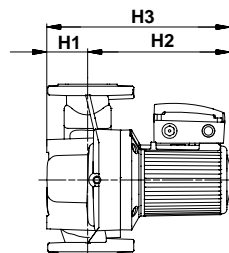
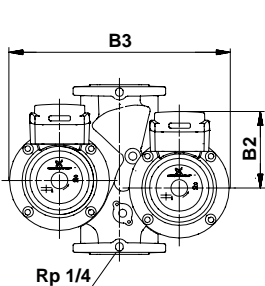
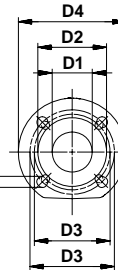
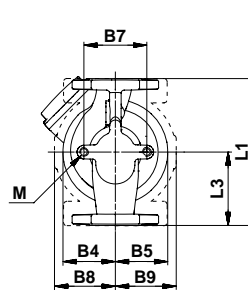
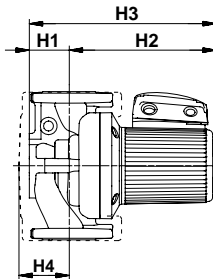
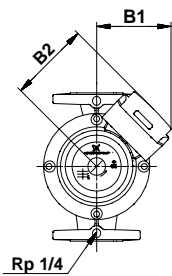
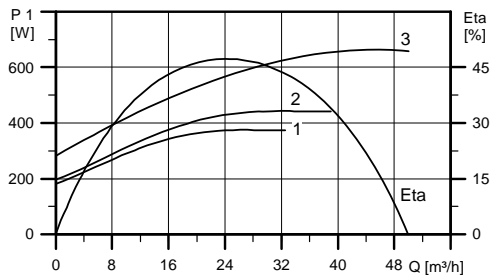
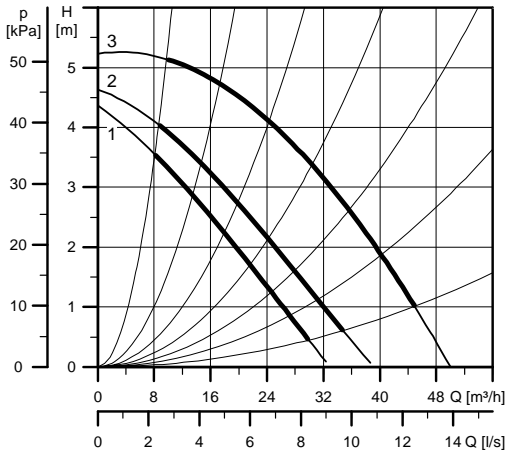

TM02 0701 3601

TM02 0703 3601

Inlet pressure

t_m [°C]	75	90	120
H_{min} [bar]	0.55	0.85	2.1

Electrical data

	P_{max} [W]	P_{min} [W]	I1/1 [A]	Cos ϕ	
3 x 230 V	Speed 1	380	185	1.18	0.81
	Speed 2	440	200	1.39	0.79
	Speed 3	660	290	2.35	0.71
3 x 400-415 V	Speed 1	380	185	0.68	0.81
	Speed 2	440	200	0.80	0.79
	Speed 3	660	290	1.35	0.71

Series 200 is also available for 1 x 230-240 V

Single-head pumps are available with bronze housing, type B.

Energy labelling

Pump type	Energy class	
	3 x 230 V	3 x 400-415 V
UPS 65-60/4 F 340	C	C
UPSD 65-60/4 F 340	D	D

Dimensions and weights

Pump type	PN	Dimensions [mm]															Weights [kg]*		Ship. vol. [m ³]						
		L1	L2	L3	B1	B2	B3	B4	B5	B6	B7	B8	B9	H1	H2	H3	H4	D1		D2	D3	D4	D5	M	Net
UPS 65-60/4 F 340	6/10 340	-	170	145	169	-	125	100	-	160	156	140	97	288	385	145	65	118	130/145	185	14/19	M16	32.5	34.5	0.055
UPSD 65-60/4 F 340	6/10 340	153	63	-	169	470	240	230	120	240	-	-	97	288	385	-	65	118	130/145	185	14/19	M12	63.0	69.9	0.125

* Weights of bronze versions are approx. 10 % higher.

UPS 65-60/2 F 340, UPSD 65-60/2 F 340

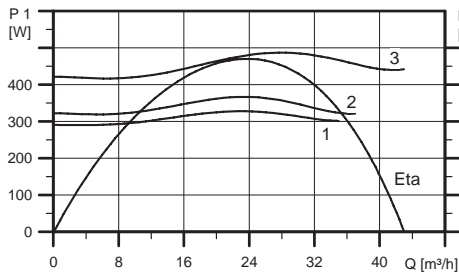
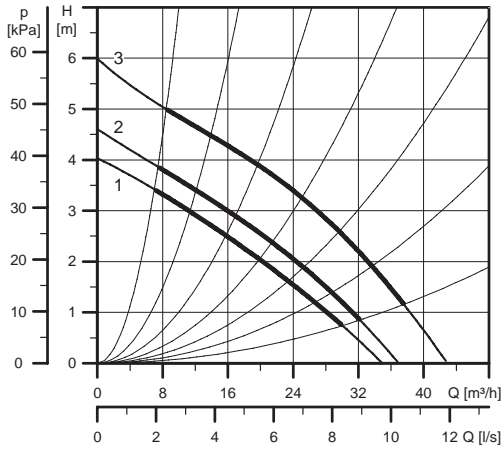

Inlet pressure

t_m [°C]	75	90	120
H_{min} [bar]	0.45	0.75	2.0

Electrical data

		P_{max} [W]	P_{min} [W]	I1/I [A]	Cos ϕ
3 x 230 V	Speed 1	330	290	0.97	0.85
	Speed 2	370	320	1.11	0.83
	Speed 3	490	420	1.83	0.67
3 x 400-415 V	Speed 1	330	290	0.56	0.85
	Speed 2	370	320	0.64	0.83
	Speed 3	490	420	1.05	0.67

Series 200 is also available for 1 x 230-240 V

Single-head pumps are available with bronze housing, type B.

Energy labelling

Pump type	Energy class	
	3 x 230 V	3 x 400-415 V
UPS 65-60/2 F 340	D	D
UPSD 65-60/2 F 340	D	D

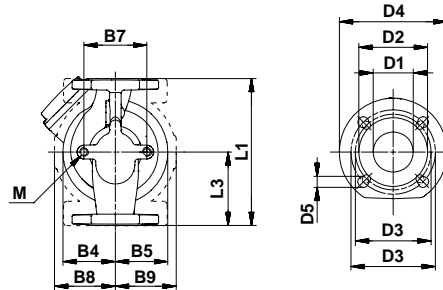
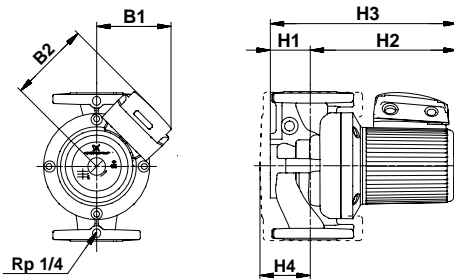

TM02 0701 3601

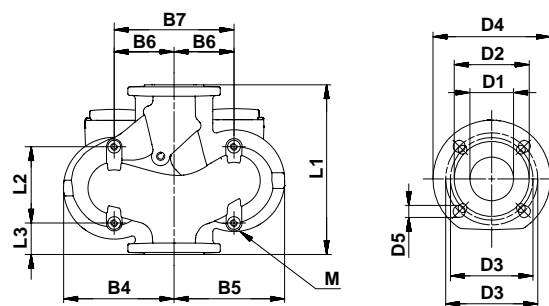
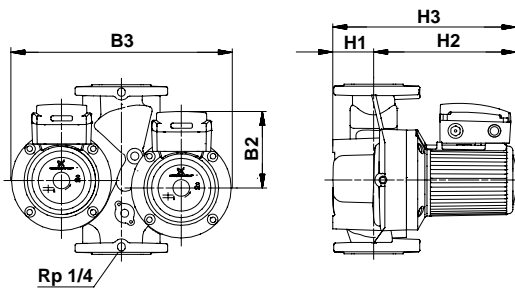

TM02 0703 3601

Dimensions and weights

Pump type	PN	Dimensions [mm]																	Weights [kg]*		Ship. vol. [m ³]				
		L1	L2	L3	B1	B2	B3	B4	B5	B6	B7	B8	B9	H1	H2	H3	H4	D1	D2	D3		D4	D5	M	Net
UPS 65-60/2 F 340	6/10 340	-	170	135	141	-	95	75	-	120	126	126	82	262	344	128	65	118	130/145	185	14/19	M12	24.3	26.1	0.043
UPSD 65-60/2 F 340	6/10 340	153	63	-	141	405	210	195	120	240	-	-	82	262	344	-	65	118	130/145	185	14/19	M12	49.0	56.9	0.125

UPS 65-60/2 F 280

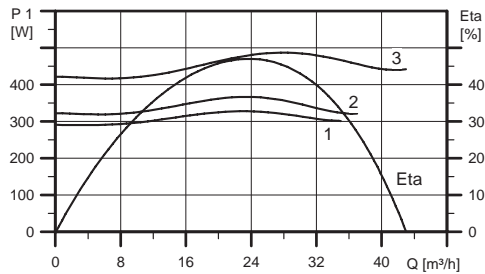
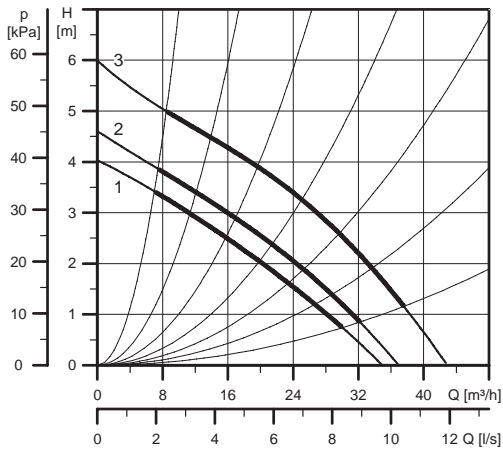

TMAO 9447 0497

Inlet pressure

t_m [°C]	75	90	120
H_{min} [bar]	0.45	0.75	2.0

Electrical data

	P_{max} [W]	P_{min} [W]	I1/I [A]	Cos ϕ	
3 x 400-415 V	Speed 1	235	185	0.39	0.87
	Speed 2	270	205	0.45	0.87
	Speed 3	360	270	0.74	0.70

Energy labelling

Pump type	Energy class
UPS 65-60/2 F 280	3 x 400-415 V C

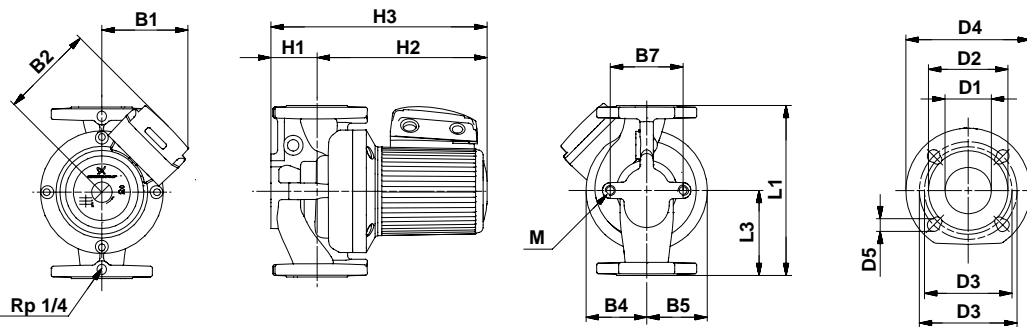

TMO3 2075 3605

Dimensions and weights

Pump type	PN	Dimensions [mm]															Weights [kg]*		Ship. vol. [m³]						
		L1	L2	L3	B1	B2	B3	B4	B5	B6	B7	B8	B9	H1	H2	H3	H4	D1		D2	D3	D4	D5	M	Net
UPS 65-60/2 F 280	6/10 280	-	140	135	141	-	87	75	-	120	-	-	75	254	329	-	65	118	130/ 145	185	14/19	M12	23.0	25.0	0.034

UPS 65-120 F 280

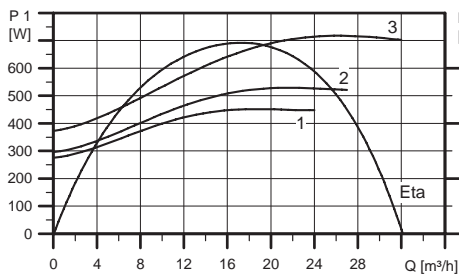
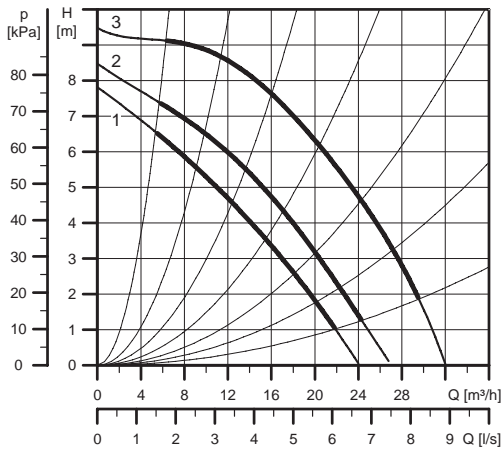

TMAO 9439 0497

Inlet pressure

t_m [°C]	75	90	120
H_{min} [bar]	0.9	1.2	2.45

Electrical data

	P_{max} [W]	P_{min} [W]	I1/I [A]	Cos ϕ	
3 x 400-415 V	Speed 1	450	280	0.82	0.79
	Speed 2	530	300	0.94	0.81
	Speed 3	720	380	1.30	0.80

Energy labelling

Pump type	Energy class
UPS 65-120 F 280	3 x 400-415 V C

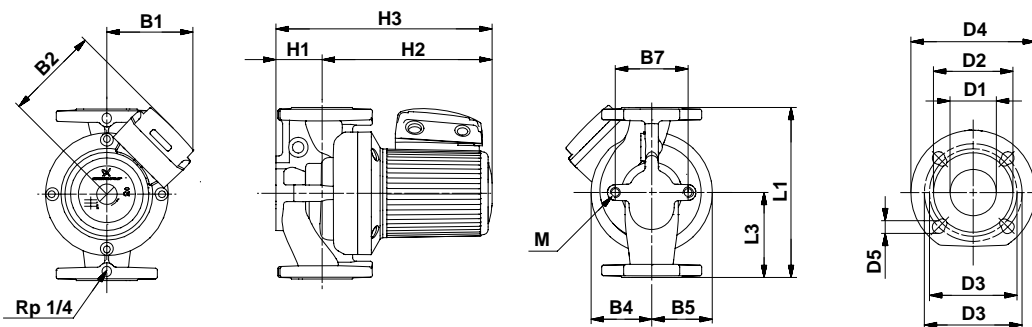

TMO3 2075 3605

Dimensions and weights

Pump type	PN	Dimensions [mm]																				Weights [kg]*		Ship. vol. [m³]	
		L1	L2	L3	B1	B2	B3	B4	B5	B6	B7	B8	B9	H1	H2	H3	H4	D1	D2	D3	D4	D5	M		Net
UPS 65-120 F 280	6/10 280	-	140	145	169	-	100	100	-	120	-	-	75	236	311	-	65	118	130/145	185	14/19	M12	25.6	27.1	0.043

UPS 65-120 F 340, UPSD 65-120 F 340

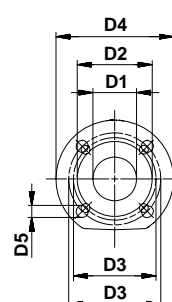
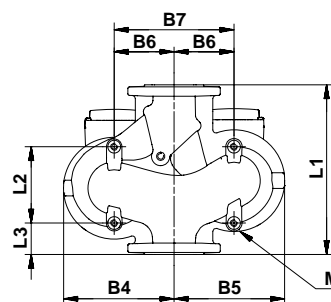
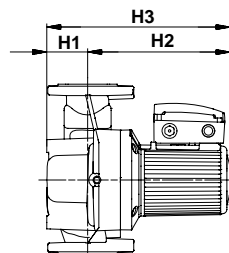
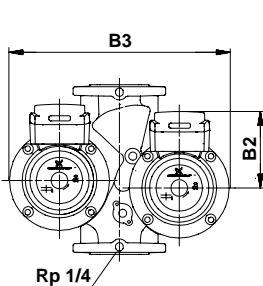
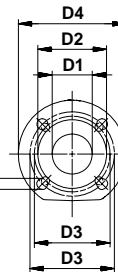
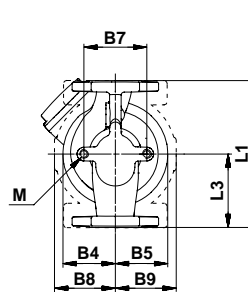
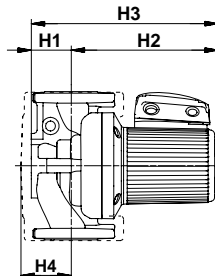
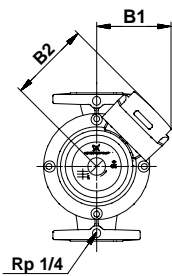
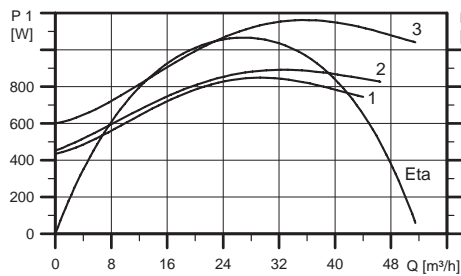
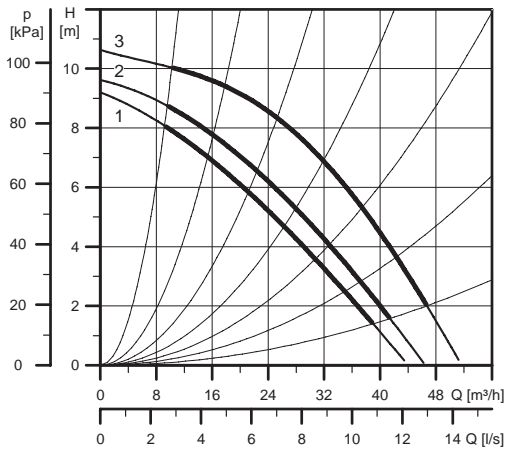

TM02 0701 3601

TM02 0703 3601

Inlet pressure

t_m [°C]	75	90	120
H_{min} [bar]	0.9	1.2	2.45

Electrical data

		P_{max} [W]	P_{min} [W]	I1/I [A]	Cos ϕ
3 x 230 V	Speed 1	850	440	2.35	0.91
	Speed 2	900	460	2.52	0.90
	Speed 3	1150	600	3.74	0.77
3 x 400-415 V	Speed 1	850	440	1.35	0.91
	Speed 2	900	460	1.45	0.90
	Speed 3	1150	600	2.15	0.77

Series 200 is also available for 1 x 230-240 V

Single-head pumps are available with bronze housing, type B.

Energy labelling

Pump type	Energy class	
	3 x 230 V	3 x 400-415 V
UPS 65-120 F 340	C	C
UPSD 65-120 F 340	C	C

Dimensions and weights

Pump type	PN	Dimensions [mm]																	Weights [kg]*		Ship. vol. [m ³]				
		L1	L2	L3	B1	B2	B3	B4	B5	B6	B7	B8	B9	H1	H2	H3	H4	D1	D2	D3		D4	D5	M	Net
UPS 65-120 F 340	6/10 340	-	170	145	169	-	100	100	-	120	140	140	82	285	367	127	65	118	130/145	185	14/19	M12	27.4	28.8	0.043
UPSD 65-120 F 340	6/10 340	153	63	-	169	450	225	225	120	240	-	-	82	286	368	-	65	118	130/145	185	14/19	M12	53.0	60.0	0.125

* Weights of bronze versions are approx. 10 % higher.

UPS 65-180 F 340, UPSD 65-180 F 340

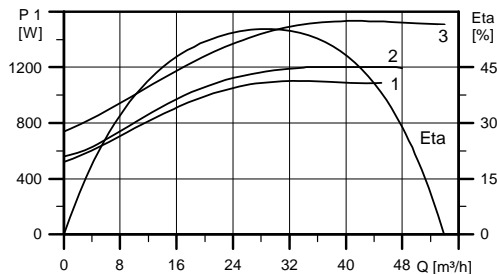
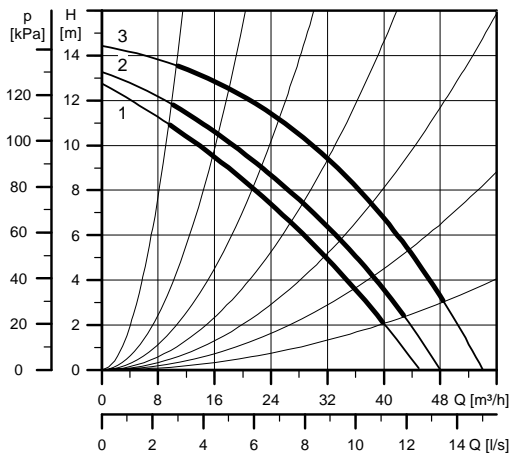

TMA0 9450 0497

Inlet pressure

t_m [°C]	75	90	120
H_{min} [bar]	0.7	1.0	2.25

Electrical data

	P_{max} [W]	P_{min} [W]	I1/1 [A]	Cos ϕ	
3 x 230 V	Speed 1	1100	520	3.22	0.86
	Speed 2	1200	560	3.48	0.87
	Speed 3	1550	740	5.04	0.77
3 x 400-415 V	Speed 1	1100	520	1.85	0.86
	Speed 2	1200	560	2.00	0.87
	Speed 3	1550	740	2.90	0.77

Single-head pumps are available with bronze housing, type B.

Energy labelling

Pump type	Energy class	
	3 x 230 V	3 x 400-415 V
UPS 65-180 F 340	C	C
UPSD 65-180 F 340	C	C

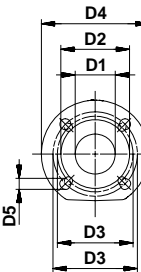
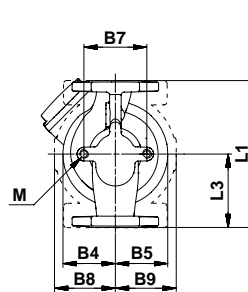
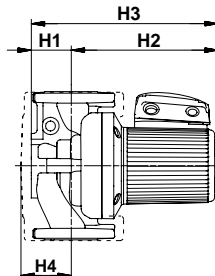
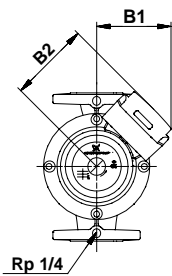

TM02 0701 3601

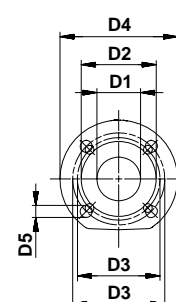
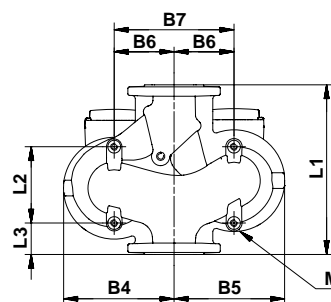
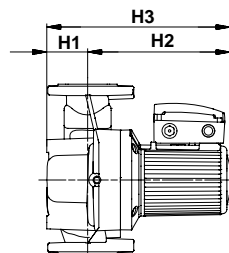
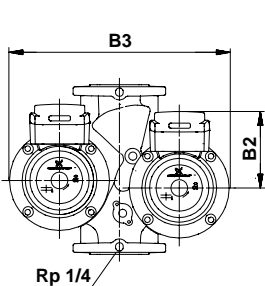

TM02 0703 3601

Dimensions and weights

Pump type	PN	Dimensions [mm]																	Weights [kg]*		Ship. vol. [m ³]				
		L1	L2	L3	B1	B2	B3	B4	B5	B6	B6	B8	B9	H1	H2	H3	H4	D1	D2	D3		D4	D5	M	Net
UPS 65-180 F 340	6/10 340	-	170	145	169	-	100	100	-	120	140	140	82	285	367	127	65	118	130/145	185	14/19	M12	29.3	33.1	0.043
UPSD 65-180 F 340	6/10 340	153	63	-	169	450	225	225	120	240	-	-	82	286	368	-	65	118	130/145	185	14/19	M12	70.0	76.9	0.125

* Weights of bronze versions are approx. 10 % higher.

UPS 65-185 F 340

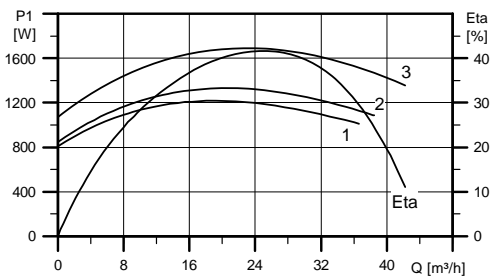
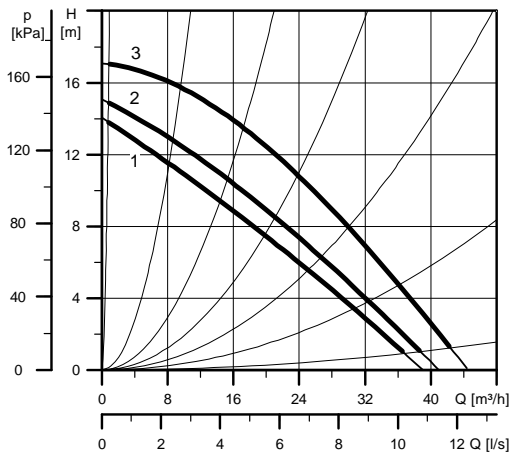

TMA1 4944 1199

Inlet pressure

t_m [°C]	75	90	120
H_{min} [bar]	0.90	1.30	2.35

Electrical data

	P_{max} [W]	P_{min} [W]	I1/1 [A]	Cos ϕ	
3 x 400-415 V	Speed 1	1220	825	2.00	0.88
	Speed 2	1340	860	2.20	0.88
	Speed 3	1710	1100	3.25	0.76

Energy labelling

Pump type	Energy class	
	3 x 230 V	3 x 400-415 V
UPS 65-185 F 340	C	C

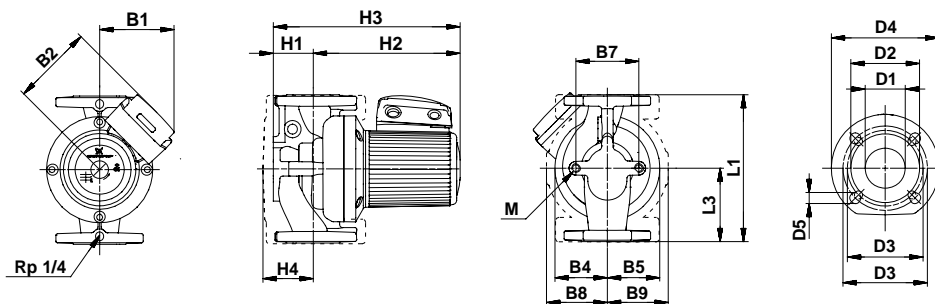

TM02 0701 3601

Dimensions and weights

Pump type	PN	Dimensions [mm]																	Weights [kg]		Ship. vol. [m ³]				
		L1	L2	L3	B1	B2	B3	B4	B5	B6	B7	B8	B9	H1	H2	H3	H4	D1	D2	D3		D4	D5	M	Net
UPS 65-185 F 340	6/10 340	-	170	145	155	-	128	100	-	96	-	-	82	282	364	-	65	118	130/145	185	14/19	M12	31.8	33.7	0.055

UPS 80-30 F 360, UPSD 80-30 F 360

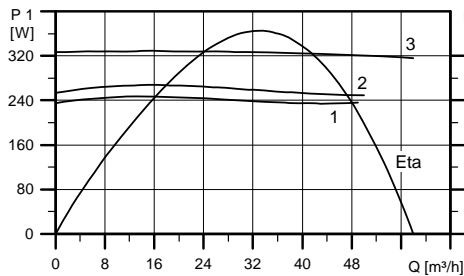
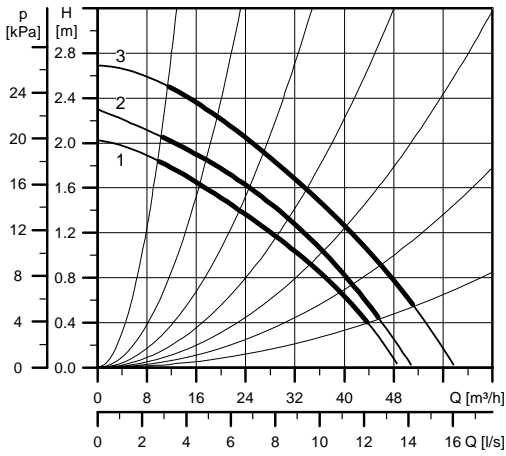

TMAO 9451 0497

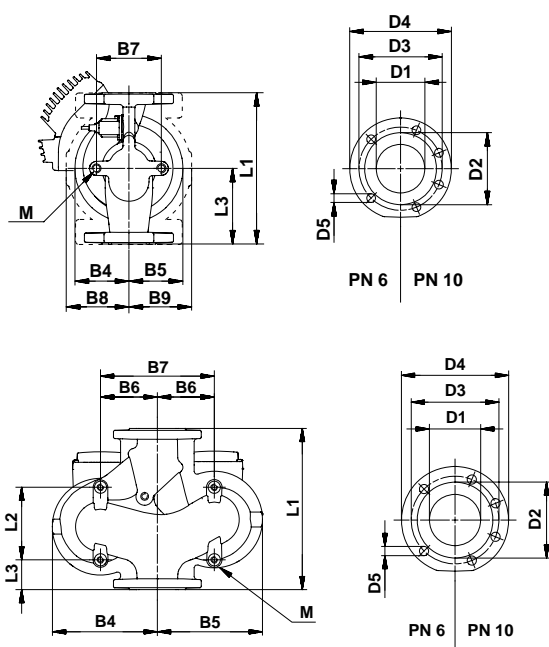
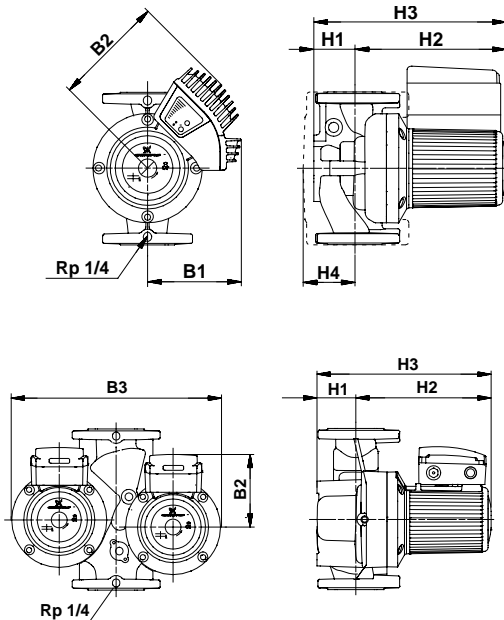

TM02 0697 3601

TM02 0815 3601

Inlet pressure

t_m [°C]	75	90	120
H_{min} [bar]	1.15	1.45	2.7

Electrical data

	P_{max} [W]	P_{min} [W]	I1/I [A]	Cos ϕ	
3 x 230 V	Speed 1	240	230	0.87	0.69
	Speed 2	260	250	1.01	0.65
	Speed 3	330	320	2.00	0.41
3 x 400-415 V	Speed 1	240	230	0.50	0.69
	Speed 2	260	250	0.58	0.65
	Speed 3	330	320	1.15	0.41

Single-head pumps are available with bronze housing, type B.

Energy labelling

Pump type	Energy class	
	3 x 230 V	3 x 400-415 V
UPS 80-30 F 360	D	D
UPSD 80-30 F 360	D	D

Dimensions and weights

Pump type	PN	Dimensions [mm]																Weights [kg]*		Ship. vol. [m³]						
		L1	L2	L3	B1	B2	B3	B4	B5	B6	B7	B8	B9	H1	H2	H3	H4	D1	D2		D3	D4	D5	M	Net	Gross
UPS 80-30 F 360	6	360	-	180	145	169	-	130	100	-	160	168	145	107	316	423	160	80	132	150	200	4x19	M16	38.0	39.9	0.055
UPS 80-30 F 360	10	360	-	180	145	169	-	130	100	-	160	168	145	107	316	423	160	80	132	160	200	8x19	M16	38.0	39.9	0.055
UPSD 80-30 F 360	6	360	173	53	-	169	470	240	230	120	240	-	-	107	316	423	-	80	132	150	200	4x19	M12	71.0	78.8	0.200
UPSD 80-30 F 360	10	360	173	53	-	169	470	240	230	120	240	-	-	107	316	423	-	80	132	160	200	8x19	M12	71.0	78.8	0.200

* Weights of bronze versions are approx. 10 % higher.

UPS 80-60 F 360, UPSD 80-60 F 360

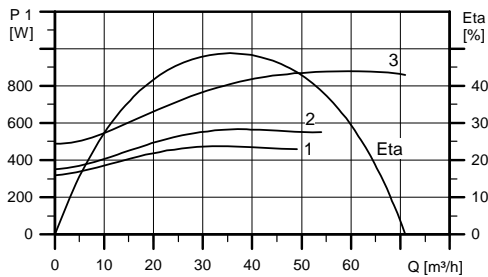
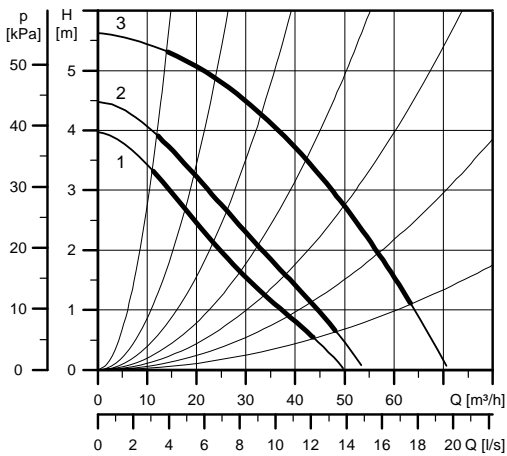

TMAO 9452 0497

Inlet pressure

t_m [°C]	75	90	120
H_{min} [bar]	1.2	1.5	2.75

Electrical data

	P_{max} [W]	P_{min} [W]	$I_{1/1}$ [A]	$\cos \phi$	
3 x 230 V	Speed 1	470	320	1.46	0.81
	Speed 2	570	350	1.74	0.82
	Speed 3	880	490	3.13	0.71
3 x 400-415 V	Speed 1	470	320	0.84	0.81
	Speed 2	570	350	1.00	0.82
	Speed 3	880	490	1.80	0.71

Single-head pumps are available with bronze housing, type B.

Energy labelling

Pump type	Energy class	
	3 x 230 V	3 x 400-415 V
UPS 80-60 F 360	C	C
UPSD 80-60 F 360	D	D

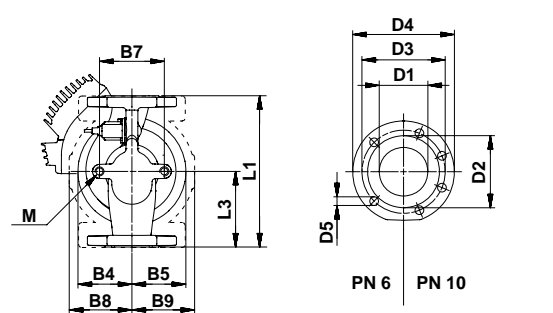
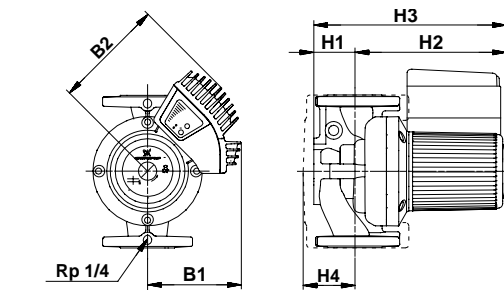

TM02 0697 3601

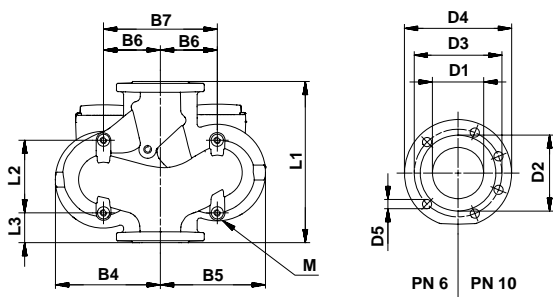
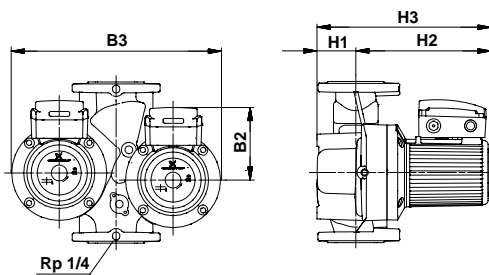

TM02 0815 3601

Dimensions and weights

Pump type	PN	Dimensions [mm]														Weights [kg]*		Ship. vol. [m³]								
		L1	L2	L3	B1	B2	B3	B4	B5	B6	B7	B8	B9	H1	H2	H3	H4		D1	D2	D3	D4	D5	M	Net	Gross
UPS 80-60 F 360	6	360	-	180	145	169	-	135	100	-	160	165	145	107	295	402	160	80	132	150	200	4x19	M16	37.3	39.2	0.055
UPS 80-60 F 360	10	360	-	180	145	169	-	135	100	-	160	165	145	107	295	402	160	80	132	160	200	8x19	M16	37.0	39.0	0.055
UPSD 80-60 F 360	6	360	173	53	-	169	490	250	240	120	240	-	-	107	294	401	-	80	132	150	200	4x19	M12	73.0	80.7	0.200
UPSD 80-60 F 360	10	360	173	53	-	169	490	250	240	120	240	-	-	107	294	401	-	80	132	160	200	8x19	M12	73.0	80.7	0.200

* Weights of bronze versions are approx. 10 % higher.

UPS 80-120 F 360, UPSD 80-120 F 360

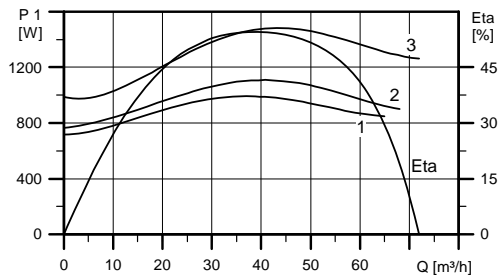
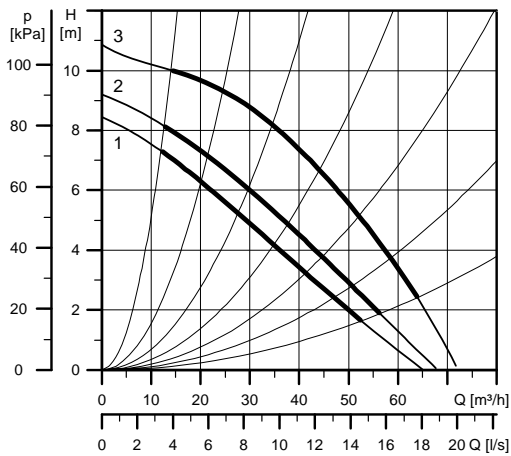

TMAO 8453 0497

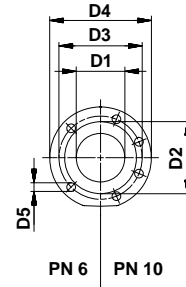
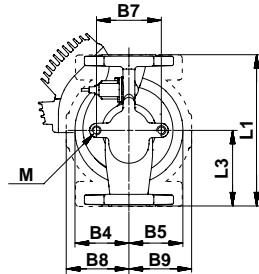
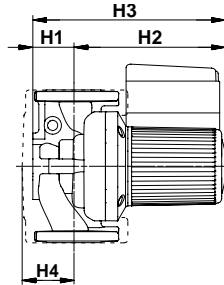
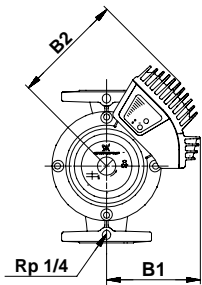

TM02 0697 3601

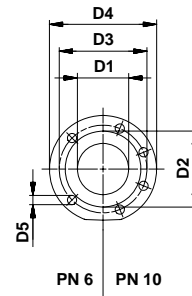
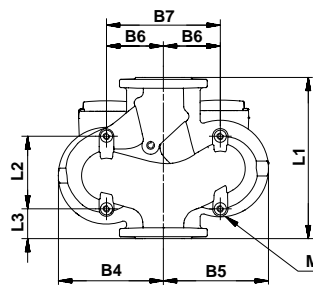
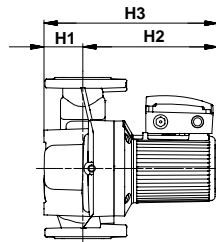
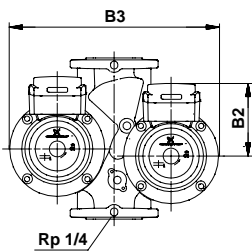

TM02 0815 3601

Inlet pressure

t_m [°C]	75	90	120
H_{min} [bar]	1.6	1.9	3.15

Electrical data

	P_{max} [W]	P_{min} [W]	I1/I [A]	Cos ϕ	
3 x 230 V	Speed 1	1000	710	2.87	0.87
	Speed 2	1100	760	3.13	0.88
	Speed 3	1500	960	4.78	0.79
3 x 400-415 V	Speed 1	1000	710	1.65	0.87
	Speed 2	1100	760	1.80	0.88
	Speed 3	1500	960	2.75	0.79

Single-head pumps are available with bronze housing, type B.

Energy labelling

Pump type	Energy class	
	3 x 230 V	3 x 400-415 V
UPS 80-120 F 360	C	C
UPSD 80-120 F 360	C	C

Dimensions and weights

Pump type	PN	Dimensions [mm]																	Weights [kg]*		Ship. vol. [m ³]					
		L1	L2	L3	B1	B2	B3	B4	B5	B6	B7	B8	B9	H1	H2	H3	H4	D1	D2	D3		D4	D5	M	Net	Gross
UPS 80-120 F 360	6	360	-	180	145	169	-	125	100	-	160	165	145	97	297	394	160	80	132	150	200	4x19	M16	36.7	38.6	0.055
UPS 80-120 F 360	10	360	-	180	145	169	-	125	100	-	160	165	145	97	297	394	160	80	132	160	200	8x19	M16	36.7	38.6	0.055
UPSD 80-120 F 360	6	360	173	53	-	169	460	235	225	120	240	-	-	97	294	391	-	80	132	150	200	4x19	M12	75.5	83.2	0.200
UPSD 80-120 F 360	10	360	173	53	-	169	460	235	225	120	240	-	-	97	294	391	-	80	132	160	200	8x19	M12	75.5	83.2	0.200

* Weights of bronze versions are approx. 10 % higher.

UPS 100-30 F 450, UPSD 100-30 F 450

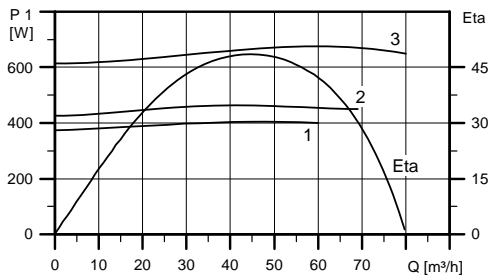
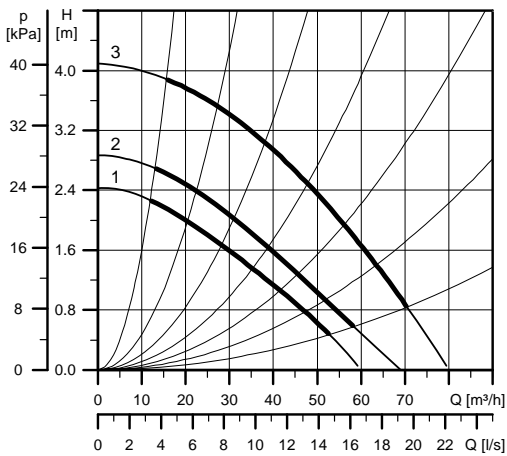

TMAO 9454 0497

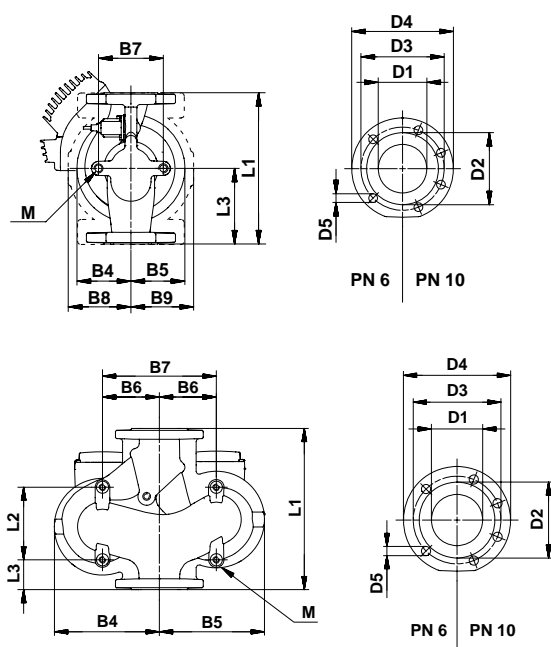
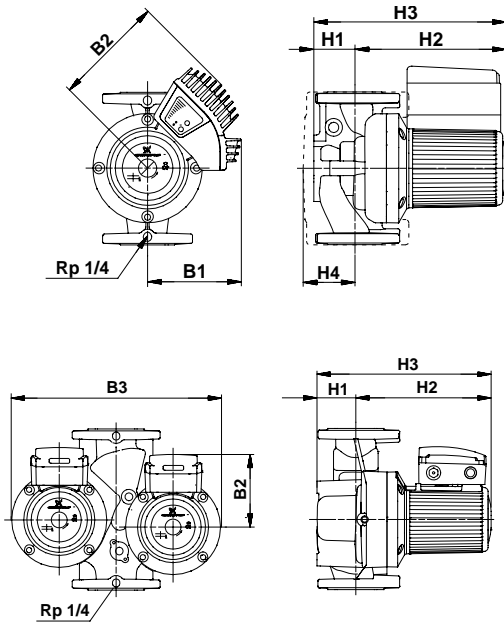

TM02 0697 3601

TM02 0815 3601

Inlet pressure

t_m [°C]	75	90	120
H_{min} [bar]	1.05	1.35	2.6

Electrical data

	P_{max} [W]	P_{min} [W]	I1/I [A]	Cos ϕ	
3 x 230 V	Speed 1	410	380	1.25	0.82
	Speed 2	460	430	1.46	0.79
	Speed 3	670	610	2.70	0.62
3 x 400-415 V	Speed 1	410	380	0.72	0.82
	Speed 2	460	430	0.84	0.79
	Speed 3	670	610	1.55	0.62

Single-head pumps are available with bronze housing, type B.

Energy labelling

Pump type	Energy class	
	3 x 230 V	3 x 400-415 V
UPS 100-30 F 450	D	D
UPSD 100-30 F 450	D	D

Dimensions and weights

Pump type	PN	Dimensions [mm]																	Weights [kg]*		Ship. vol. [m³]					
		L1	L2	L3	B1	B2	B3	B4	B5	B6	B7	B8	B9	H1	H2	H3	H4	D1	D2	D3		D4	D5	M	Net	Gross
UPS 100-30 F 450	6	450	-	225	145	169	-	175	120	-	200	226	174	122	316	438	186	100	156	170	220	4x19	M16	46.5	49.0	0.087
UPS 100-30 F 450	10	450	-	225	145	169	-	175	120	-	200	226	174	122	316	438	186	100	156	180	220	8x19	M16	46.5	49.0	0.087
UPSD 100-30 F 450	6	450	221	83	-	169	595	280	315	140	280	-	-	122	316	438	-	100	156	170	220	4x19	M16	97.4	105.1	0.200
UPSD 100-30 F 450	10	450	221	83	-	169	595	280	315	140	280	-	-	122	316	438	-	100	156	180	220	8x19	M16	97.4	105.1	0.200

* Weights of bronze versions are approx. 10 % higher.

Accessories

The following accessories are available for UPS, UPSD pumps:

- protection module
- relay module for single-head pumps
- relay module kit for twin-head pumps
- counter flanges (standard on pumps for the UK)
- insulation kit (only single-head pumps)
- base plate (only single-head pumps)
- blanking flanges (only twin-head pumps).

Counter flanges

A counter flange kit includes these parts:

- two flanges with internal thread (ISO seal thread) or two flanges for welding/soldering
- two gaskets
- bolts.

Product numbers of counter flanges

Rp: Flange with internal thread (ISO seal thread).

mm: Flange for welding/soldering.

Pumps with cast iron pump housing			
Pump type	Pressure stage	Size	Product number
UPS/UPSD 32	PN 10	Rp 1 1/4	539703
		32 mm	539704
UPS/UPSD 40	PN 10	Rp 1 1/2	539701
		40 mm	539702
UPS/UPSD 50	PN 10	Rp 2	549801
		50 mm	549802
UPS/UPSD 65	PN 10	Rp 2 1/2	559801
		65 mm	559802
UPS/UPSD 80	PN 6	Rp 3	569902
		80 mm	569901
	PN 10	Rp 3	569802
		80 mm	569801
UPS/UPSD 100	PN 6	Rp 4	579901
		100 mm	579902
	PN 10	Rp 4	579801
		100 mm	579802

Pumps with bronze pump housing			
Pump type	Pressure stage	Size	Product number
UPS 32	PN 10	Rp 1 1/4	96427029
		32 mm	96427030
UPS 40	PN 10	Rp 1 1/2	539711
		40 mm	539712
UPS 50	PN 10	Rp 2	549811
		50 mm	549812
UPS 65	PN 10	Rp 2 1/2	559811
		65 mm	559812
UPS 80	PN 6	Rp 3	96405735
		80 mm	569911
	PN 10	Rp 3	569812
		80 mm	569811
UPS 100	PN 6	Rp 4	96405737
	PN 10	Rp 4	96405738

Protection modules

Voltage [V]	Product number
1 x 230-240	96422219
3 x 230	96422220
3 x 400-415	96422221

Relay module

Relay modules for single-head pumps.

Voltage [V]	Product number
1 x 230-240	96406611
3 x 230	96406610
3 x 400-415	96406609

A relay module kit for twin-head pumps includes these parts:

- two relay modules with screws and screwdriver
- two screwed cable entries
- one intermediate cable
- two wiring diagrams for terminal box covers.

Voltage [V]	Product number
1 x 230-240	96409231
3 x 230	96409230
3 x 400-415	96409229

Insulation kits

Single-head pumps can be fitted with an insulation covering made of expanded polypropylene, EPP.

The insulation kit, which is tailored to the individual pump type, has an insulating thickness corresponding to the nominal diameter of the pump.

The thermal conductivity of EPP is very low (0.04 W/m°C), i.e. the insulating property is very good.

The insulation kit encloses the entire pump housing. It consists of two or three parts which are easily fitted around the pump.

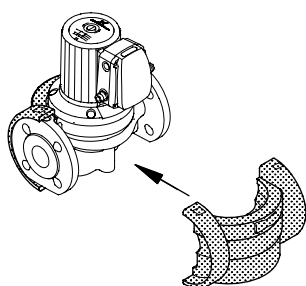

Fig. 20 Insulation kit

Product numbers of insulation kits

Pump type	Product number
UPS 32-30 F 220	96405871
UPS 32-60 F 220	96405873
UPS 32-120 F 220	96405873
UPS 40-30 F 250	96405874
UPS 40-60/4 F 250	96405875
UPS 40-60/2 F 250	96405877
UPS 40-120 F 250	96405877
UPS 40-180 F 250	96405878
UPS 50-30 F 280	96405879
UPS 50-60/4 F 280	96405880
UPS 50-60/2 F 280	96405881
UPS 50-120 F 280	96405882
UPS 50-180 F 280	96405883
UPS 65-30 F 340	96405884
UPS 65-60/4 F 340	96405885
UPS 65-60/2 F 340	96405886
UPS 65-120 F 340	96405887
UPS 65-180 F 340	96405888
UPS 80-30 F 360	96405889
UPS 80-60 F 360	96405890
UPS 80-120 F 360	96405891
UPS 100-30 F 450	96405892

TM02 1406 0702

Base plate

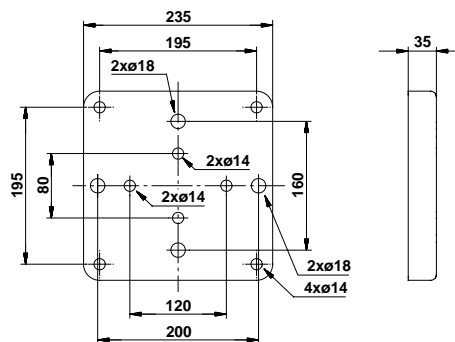

TM00 9835 0197

Fig. 21 Base plate

Product numbers of base plates

Pump type	Product number*
UPS 32-30, -60, -120 UPS 40-30, -60/4, -60/2, -120, -180 UPS 50-30, -60/4, -60/2, -120, -180 UPS 65-60/2, -120, -180	96405915
UPS 65-30, -60/4 UPS 80-30, -60, -120 UPS 100-30	96405914
UPS 40-185 UPS 50-185 UPS 65-185	495035

* Product numbers include a base plate and two bolts.

Only available for single-head pumps.

Blanking flanges

For twin-head pumps a blanking flange with pump housing seal is available as an optional extra. The blanking flange is used when servicing one of the power heads to enable uninterrupted operation of the other.

Product number of blanking flanges

Pump type	Product number
UPSD 32-30 F 220	
UPSD 32-60 F 220	
UPSD 32-120 F 220	
UPSD 40-30 F 250	545048
UPSD 40-60 F 250	
UPSD 40-60/2 F 250	
UPSD 40-120 F 250	
UPSD 50-30 F 280	
UPSD 50-60/4 F 280	565055
UPSD 50-60/2 F 280	545048
UPSD 50-120 F 280	
UPSD 50-180 F 280	565055
UPSD 65-30 F 340	
UPSD 65-60/4 F 340	
UPSD 65-60/2 F 340	545048
UPSD 65-120 F 340	
UPSD 65-180 F 340	
UPSD 80-30 F 360	565055
UPSD 80-60 F 360	
UPSD 80-120 F 360	
UPSD 100-30 F 450	

WebCAPS

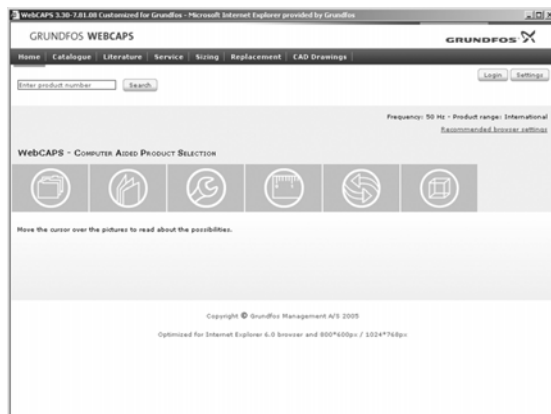

WebCAPS is a **Web**-based **Computer Aided Product Selection** program available on www.grundfos.com.

WebCAPS contains detailed information on more than 185,000 Grundfos products in more than 20 languages.

In WebCAPS, all information is divided into 6 sections:

- Catalogue
- Literature
- Service
- Sizing
- Replacement
- CAD drawings.

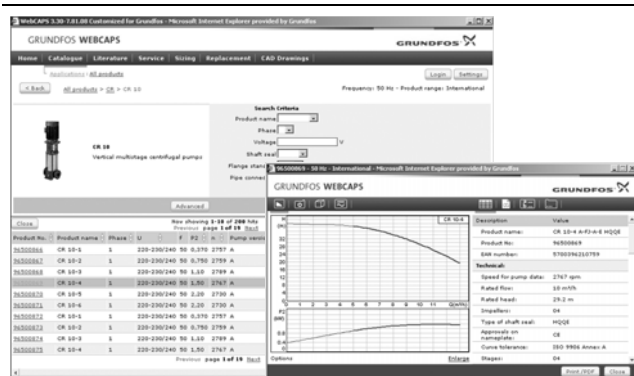

Catalogue

This section is based on fields of application and pump types, and contains

- technical data
- curves (QH, Eta, P1, P2, etc) which can be adapted to the density and viscosity of the pumped liquid and show the number of pumps in operation
- product photos
- dimensional drawings
- wiring diagrams
- quotation texts, etc.

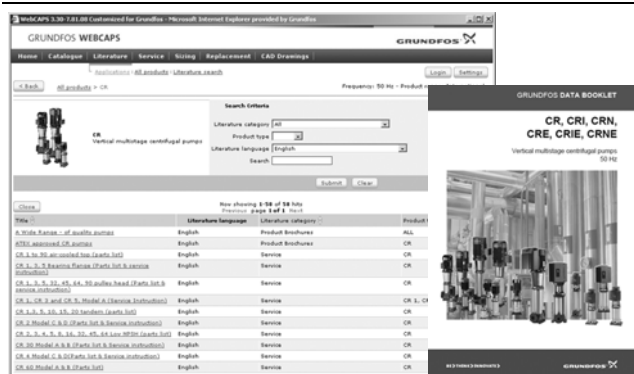

Literature

In this section you can access all the latest documents of a given pump, such as

- data booklets
- installation and operating instructions
- service documentation, such as Service kit catalogue and Service kit instructions
- quick guides
- product brochures.

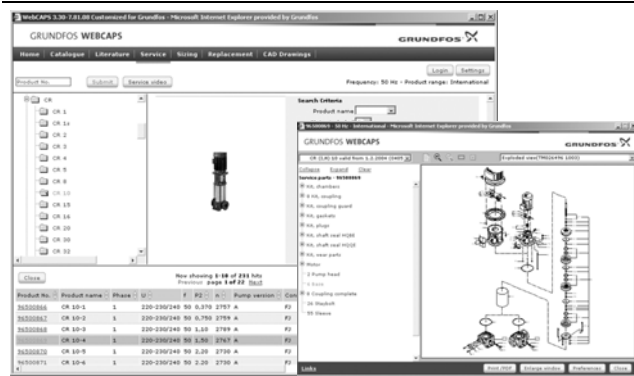

Service

This section contains an easy-to-use interactive service catalogue. Here you can find and identify service parts of both existing and discontinued Grundfos pumps. Furthermore, this section contains service videos showing you how to replace service parts.



Sizing

This section is based on different fields of application and installation examples, and gives easy step-by-step instructions in how to

- select the most suitable and efficient pump for your installation
- carry out advanced calculations based on energy consumption, payback periods, load profiles, life cycle costs, etc.
- analyse your selected pump via the built-in life cycle cost tool
- determine the flow velocity in wastewater applications, etc.

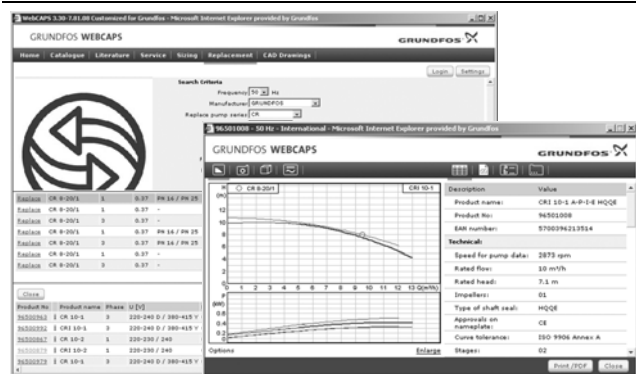

Replacement

In this section you find a guide to selecting and comparing replacement data of an installed pump in order to replace the pump with a more efficient Grundfos pump. The section contains replacement data of a wide range of pumps produced by other manufacturers than Grundfos.

Based on an easy step-by-step guide, you can compare Grundfos pumps with the one you have installed on your site. When you have specified the installed pump, the guide will suggest a number of Grundfos pumps which can improve both comfort and efficiency.

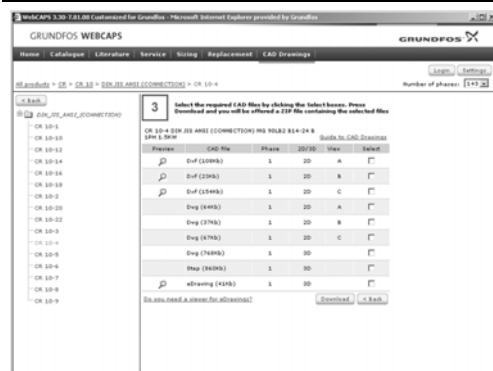

CAD drawings

In this section it is possible to download two-dimensional (2D) and three-dimensional (3D) CAD drawings of most Grundfos pumps.

These formats are available in WebCAPS:

- Two-dimensional drawings:
- .dxf, wireframe drawings
 - .dwg, wireframe drawings.
- Three-dimensional drawings:
- .dwg, wireframe drawings (without surfaces)
 - .stp, solid drawings (with surfaces)
 - .eprt, E-drawings.

WinCAPS



Fig. 22 WinCAPS CD-ROM

WinCAPS is a **Windows-based Computer Aided Product Selection** program containing detailed information on more than 185,000 Grundfos products in more than 20 languages.

The program contains the same features and functions as WebCAPS, but is an ideal solution if no Internet connection is available.

WinCAPS is available on CD-ROM and updated once a year.

V7124415 0307	GB
Repl. V7124415 0105	

Subject to alterations.