

FEKA VS GRINDER

SUBMERSIBLE PUMPS WITH SHREDDER FOR SEWAGE

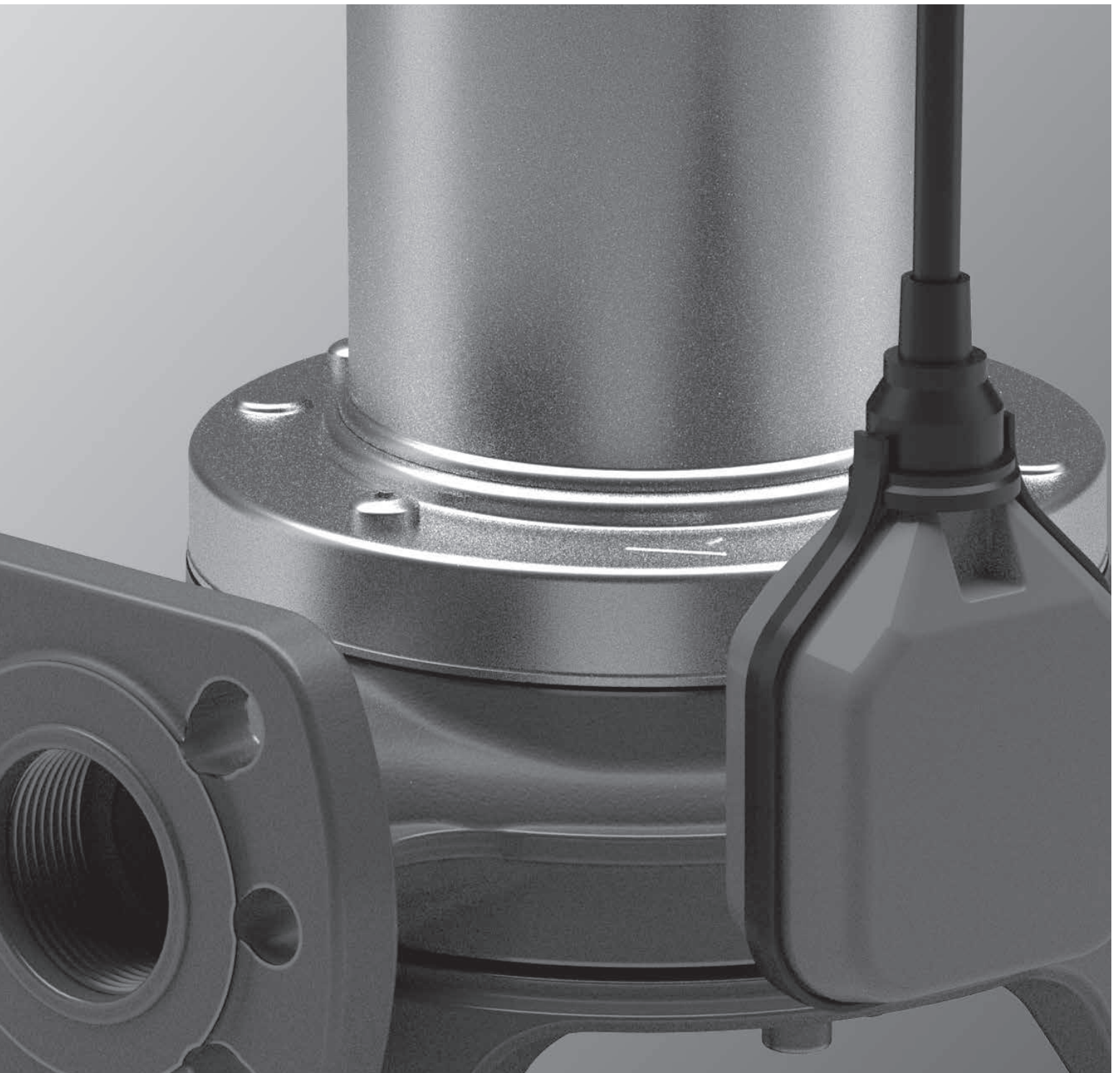

FEKA VS GRINDER

SUBMERSIBLE PUMP



TECHNICAL DATA

Flow rate: from 0 m³h to 14,4 m³h
Head: 25 m
Pumped liquid: sewage water, gray water
Free passage: n/a
Liquid temperature: from 0°C to +40°C for domestic use
Outlet: 1" 1/2 GAS - DN 32 and DN 40
Outlet direction: horizontal and vertical with curve kit accessory
Impeller: vortex in cast iron, there is a shredder
Motor protection degree: IP 68
Thermal classification of the motor insulation: F
Power cable type: H07RN8-F
Possible type of installation: fixed or mobile in vertical position
Maximum immersion depth: 7 meters

Submersible pump for draining wastewater in commercial building service. The pump is certified to the European Union standard EN 12050-1 which applies to lifting systems for waste water containing fecal material in buildings and construction sites. Thanks to the shredder, the pump is suitable for systems with small diameter pipes or those requiring high pressures. Pump suitable for fixed installations with coupling device or mobile installation if placed directly on the bottom of the tank. Construction according to CEI 2-3 CEI 61-69 (EN 60335-2-41) standards. Single-phase versions is available in automatic version with integrated float switch or in the manual version without float switch.

CONSTRUCTION FEATURES OF THE PUMP

The motor shaft is in AISI 316 stainless steel. Double mechanical seal with interposed oil chamber (non-toxic oil) in carbon/alumina on the motor side and silicon carbide/silicon carbide on the pump side. Seal holder cover, motor case, cap and handle are made in stainless steel. The pump body and the base are in cast iron. The shredding system is in AISI 630 stainless steel. The handle is covered in insulating rubber.

CONSTRUCTION FEATURES OF THE MOTOR

The motor is asynchronous, it is watertight, cooled by the pumped liquid. The rotor is mounted on greased-for-life ball bearings, oversized and selected to ensure low noise and durability. Standard thermo-amperometric protection for the single-phase version with capacitor inserted as standard, the three-phase version has a thermal protection which can be connected to a control panel.

MATERIALS

N°	PARTS*	MATERIALS	
1	PUMP HOUSING	CAST IRON	
2	PUMP BASE	CAST IRON	
3	IMPELLER	CAST IRON	
4	CUTTER BASE	STAINLESS STEEL	
5	CUTTER	STAINLESS STEEL	
6	SHAFT SEAL DISC	STAINLESS STEEL	
7	MOTOR CONNECTION FLANGE	STAINLESS STEEL	
8	LOWER BEARING SUPPORT	ALUMINUM	
9	DOUBLE MECHANICAL SEAL	PUMP SIDE	SIC/SIC
		MOTOR SIDE	CARBON / ALUMINA
10	MOTOR CASE	STAINLESS STEEL	
11	MOTOR SHAFT	STAINLESS STEEL	
12	UPPER BEARING SUPPORT	ALUMINUM	
13	COVER CONNECTION	STAINLESS STEEL	
14	HANDLE	STAINLESS STEEL AND INSULATING RUBBER	
15	SUPPLY CABLE	H07RN8-F	
16	FLOAT SWITCH CABE	H07RN-F	
17	O-RINGS	NBR	
18	CABLE GLAND	NICHEL-PLATED BRASS	

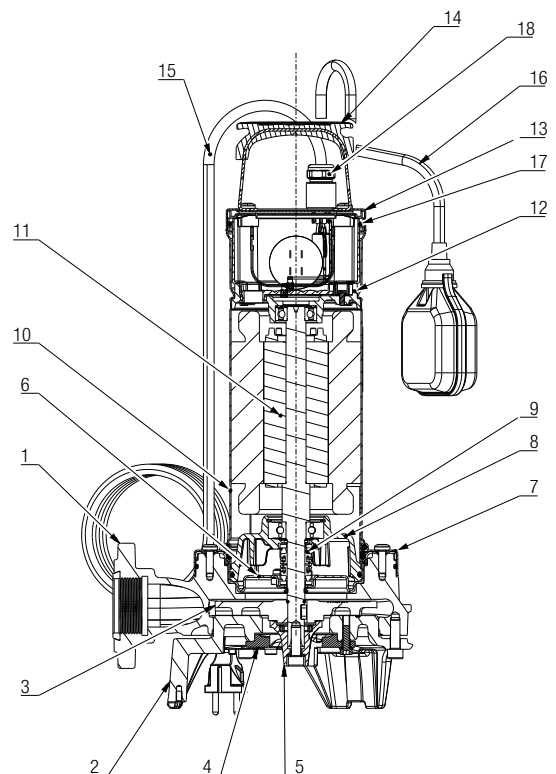

* In contact with the liquid

FEKA VS GRINDER - SUBMERSIBLE PUMPS WITH SHREDDER FOR SEWAGE

Liquid temperature range: from 0°C a +40°C for domestic use.

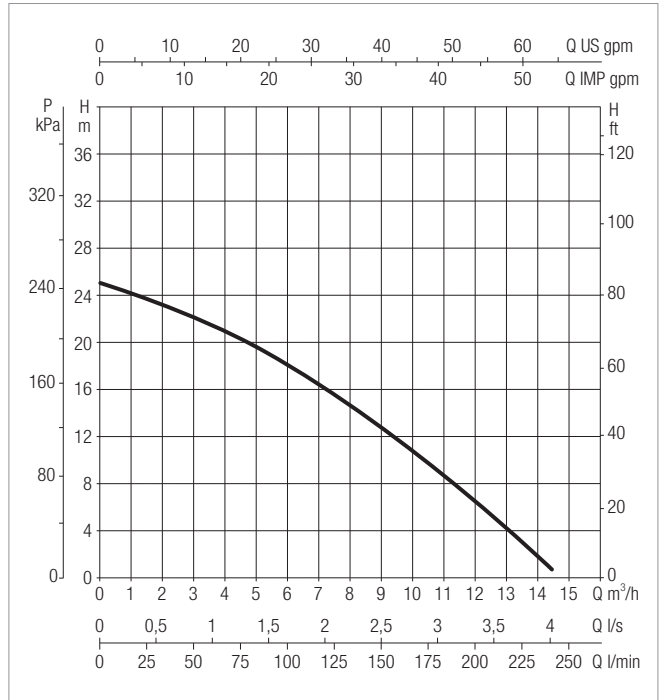
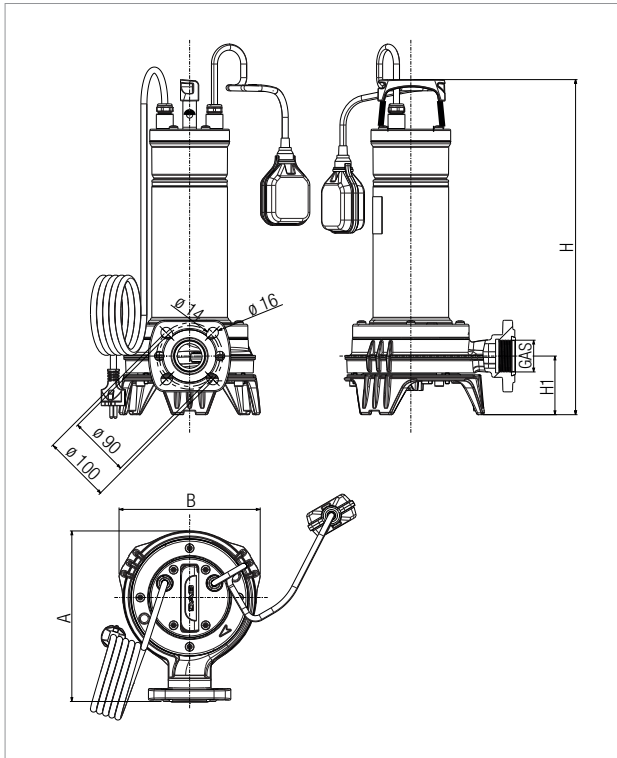

The performance curves are based on kinematic viscosity values = 1 mm²/s and density equal to 1000 kg/m³. Curve tolerance according to ISO 9906.

PERFORMANCE AT 50 HZ

MODEL	HYDRAULIC DATA										
	Q=m ³ /h	0	2	4	6	8	9	10	11	12	14
	Q=l/min	0	34	66	100	135	150	168	180	200	240
FEKA VS GRINDER 1000 MA	H (m)	25	23	21	18	14,5	12,8	10,5	9	6,5	0,67
FEKA VS GRINDER 1000 M-NA		25	23	21	18	14,5	12,8	10,5	9	6,5	0,67
FEKA VS GRINDER 1000 TNA		25	23	21	18	14,5	12,8	10,5	9	6,5	0,67

ELECTRICAL DATA

MODEL	ELECTRICAL DATA							
	POWER INPUT 50 Hz	P1 MAX W	P2 NOMINAL		I _n A	I _{st} A	CAPACITOR	
			kW	HP			µF	Vc
FEKA VS GRINDER 1000 MA	220 x 240V	1,3	1	1,3	6,4 A	29,9	35	450
FEKA VS GRINDER 1000 M-NA	220 x 240V	1,3	1	1,3	6,2 A	29,9	35	450
FEKA VS GRINDER 1000 TNA	380 x 415V	1,3	1	1,3	3 A	19,8	-	-

DIMENSIONAL DATA

MODEL	A	B	H	H1	GAS	DN1	HOLES	PACKING DIMENSIONS			VOLUME (mc)	WEIGHT Kg
								L/A	L/B	H		
FEKA VS GRINDER 1000	253	209	496	87	Rp 1" 1/2	DN32 PN10 / 6 DN40 PN6	4 2	290	230	560	0,037	23

DNA[®]

PUMPS SELECTOR



On-line product selection



DAB PUMPS LTD.

6 Gilbert Court
Newcomen Way
Severalls Business Park
Colchester
Essex
CO4 9WN - UK
salesuk@dwtgroup.com
Tel. +44 0333 777 5010



DAB PUMPS IBERICA S.L.

Calle Verano 18-20-22
28850 - Torrejón de Ardoz - Madrid
Spain
Info.spain@dwtgroup.com
Tel. +34 91 6569545
Fax: + 34 91 6569676



DAB PUMPS (QINGDAO) CO. LTD.

No.40 Kaituo Road, Qingdao Economic
& Technological
Development Zone
Qingdao City, Shandong Province - China
PC: 266500
sales.cn@dwtgroup.com
Tel. +86 400 186 8280
Fax +86 53286812210



DAB PUMPS BV

*Hofveld 6 C1
1702 Groot Bijgaarden - Belgium
info.belgium@dwtgroup.com
Tel. +32 2 4668353



DAB PUMPS HUNGARY KFT.

H-8800
Nagykanizsa, Buda Erő u.5
Hungary
Tel. +36 93501700



DAB PUMPS DE MÉXICO, S.A. DE C.V.

Av Amsterdam 101 Local 4
Col. Hipódromo Condesa,
Del. Cuauhtémoc CP 06170
Ciudad de México
Tel. +52 55 6719 0493



DAB PUMPS POLAND Sp. z o.o.

Ul. Janka Muzykanta 60
02188 Warszawa - Poland
polska@dabpumps.com.pl



DAB PUMPS OCEANIA PTY LTD

426 South Gippsland Highway,
Dandenong South VIC 3175 - Australia
info.oceania@dwtgroup.com
Tel. +61 1300 378 677



DAB PUMPS B.V.

Albert Einsteinweg, 4
5151 DL Drunen - Nederland
info.netherlands@dwtgroup.com
Tel. +31 416 387280
Fax +31 416 387299



DAB PUMPS INC.

3226 Benchmark Drive
Ladson, SC 29456 - USA
info.usa@dwtgroup.com
Tel. 1 - 843-797-5002
Fax 1-843-797-3366



DAB PUMPS GMBH

Am Nordpark 3
D - 41069 Mönchengladbach - Germany
info.germany@dwtgroup.com
Tel. +49 2161 47388-0
Fax +49 2161 47388-36



DAB PUMPS SOUTH AFRICA (PTY) LTD

Twenty One industrial Estate,
16 Purlin Street, Unit B, Warehouse 4
Olifantsfontein -1667 - South Africa
info.sa@dwtgroup.com
Tel. +27 12 361 3997



PT DAB PUMPS INDONESIA

Satrio Tower lantai 26
unit C-D, Jl. Prof. Dr. Satrio Kav. C4,
Kel. Kuningan Timur, Kec. Setiabudi, Kota Adm.
Jakarta Selatan, Prov. DKI Jakarta. - Indonesia
Tel. +62 2129222850