

Installation, Operation, and
Maintenance

898397_4.0

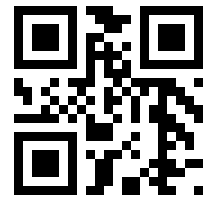

2008 Ready 8, 8S

Table of Contents

1 Introduction and Safety	3
1.1 Introduction.....	3
1.2 Safety terminology and symbols.....	3
1.3 User safety.....	4
1.4 Special hazards.....	4
1.5 Protecting the environment.....	5
1.6 Spare parts.....	5
1.7 Warranty.....	5
2 Transportation and Storage	6
2.1 Inspect the delivery.....	6
2.1.1 Inspect the package.....	6
2.1.2 Inspect the unit.....	6
2.2 Transportation guidelines.....	6
2.2.1 Lifting.....	6
2.3 Temperature ranges for transportation, handling and storage.....	7
2.4 Storage guidelines.....	7
3 Product Description	8
3.1 Products included.....	8
3.2 Pump design.....	8
3.3 Monitoring equipment.....	8
3.3.1 Level regulators.....	8
3.4 The data plate.....	9
3.5 Product denomination.....	10
4 Installation	11
4.1 Install the pump.....	11
4.1.1 Install with S-installation.....	12
4.2 Make the electrical connections.....	13
4.2.1 Connect the motor cable to the pump.....	15
4.2.2 Cable charts.....	16
4.3 Check the impeller rotation.....	17
5 Operation	18
5.1 Precautions.....	18
5.2 Start the pump.....	18
5.3 Clean the pump.....	19
6 Maintenance	20
6.1 Torque values.....	21
6.2 Service.....	21
6.3 Change the oil.....	21
6.4 Replace the impeller.....	22
6.4.1 Remove the impeller, drainage version.....	23
6.4.2 Remove the impeller, sludge version.....	24
6.4.3 Install the impeller, drainage version.....	25
6.4.4 Install the impeller, sludge version.....	26
6.5 Replace the motor cable.....	28
6.5.1 Remove the motor cable.....	28

6.5.2 Install the motor cable.....29

7 Troubleshooting..... 31

7.1 The pump does not start.....31

7.2 The pump does not stop when a level sensor is used..... 32

7.3 The pump starts-stops-starts in rapid sequence.....33

7.4 The pump runs but the motor protection trips..... 33

7.5 The pump delivers too little or no water.....34

8 Technical Reference.....36

8.1 Application limits..... 36

8.2 Motor data..... 36

8.3 Specific motor data: Ready 8..... 36

8.4 Specific motor data: Ready 8S..... 37

8.5 Dimensions and weights.....38

8.6 Performance curves..... 39

1 Introduction and Safety

1.1 Introduction

Purpose of the manual

The purpose of this manual is to provide necessary information for working with the unit. Read this manual carefully before starting work.

Read and keep the manual

Save this manual for future reference, and keep it readily available at the location of the unit.

Intended use



WARNING:

Operating, installing, or maintaining the unit in any way that is not covered in this manual could cause death, serious personal injury, or damage to the equipment and the surroundings. This includes any modification to the equipment or use of parts not provided by Xylem. If there is a question regarding the intended use of the equipment, please contact a Xylem representative before proceeding.

Other manuals

See also the safety requirements and information in the original manufacturer's manuals for any other equipment furnished separately for use in this system.

1.2 Safety terminology and symbols

About safety messages

It is extremely important that you read, understand, and follow the safety messages and regulations carefully before handling the product. They are published to help prevent these hazards:



- Personal accidents and health problems
- Damage to the product and its surroundings
- Product malfunction

Hazard levels

Hazard level	Indication
DANGER:	A hazardous situation which, if not avoided, will result in death or serious injury
WARNING:	A hazardous situation which, if not avoided, could result in death or serious injury
CAUTION:	A hazardous situation which, if not avoided, could result in minor or moderate injury
NOTICE:	Notices are used when there is a risk of equipment damage or decreased performance, but not personal injury.

Special symbols

Some hazard categories have specific symbols, as shown in the following table.

Electrical hazard	Magnetic fields hazard
 <p>Electrical Hazard:</p>	 <p>CAUTION:</p>

1.3 User safety

All regulations, codes, and health and safety directives must be observed.

The site

- Observe lockout/tagout procedures before starting work on the product, such as transportation, installation, maintenance, or service.
- Pay attention to the risks presented by gas and vapors in the work area.
- Always be aware of the area surrounding the equipment, and any hazards posed by the site or nearby equipment.

Qualified personnel

This product must be installed, operated, and maintained by qualified personnel only.

Protective equipment and safety devices

- Use personal protective equipment as needed. Examples of personal protective equipment include, but are not limited to, hard hats, safety goggles, protective gloves and shoes, and breathing equipment.
- Make sure that all safety features on the product are functioning and in use at all times when the unit is being operated.

1.4 Special hazards

Working in temporary installations

Certain industries, such as mining or construction, have a dynamic nature and require temporary installation of equipment. Due to the rugged nature of these applications, normal use of electrical equipment causes wear and tear that can result in insulation breaks, short-circuits, and exposed wires. To maximize safety when using the unit in rugged applications, the following conditions must be met:

- If electrical cables must be located such that they are at risk of being run over by heavy equipment, then provide mechanical protection to prevent physical damage to the cables.
- Visually inspect electrical equipment before use. Remove from service any equipment with exposed wires or visible damage.
- Use ground-fault circuit interrupters on all receptacles, or have an assured equipment grounding conductor program.

Biological hazards

The product is designed for use in liquids that can be hazardous to your health. Observe these rules when you work with the product:

- Make sure that all personnel who may come into contact with biological hazards are vaccinated against diseases to which they may be exposed.
- Observe strict personal cleanliness.



WARNING: Biological Hazard

Infection risk. Rinse the unit thoroughly with clean water before working on it.

Wash the skin and eyes

Follow these procedures for chemicals or hazardous fluids that have come into contact with your eyes or your skin:

Condition	Action
Chemicals or hazardous fluids in eyes	<ol style="list-style-type: none"> 1. Hold your eyelids apart forcibly with your fingers. 2. Rinse the eyes with eyewash or running water for at least 15 minutes. 3. Seek medical attention.
Chemicals or hazardous fluids on skin	<ol style="list-style-type: none"> 1. Remove contaminated clothing. 2. Wash the skin with soap and water for at least 1 minute. 3. Seek medical attention, if necessary.

1.5 Protecting the environment

Emissions and waste disposal

Observe the local regulations and codes regarding:

- Reporting of emissions to the appropriate authorities
- Sorting, recycling and disposal of solid or liquid waste
- Clean-up of spills

Exceptional sites



CAUTION: Radiation Hazard

Do NOT send the product to Xylem if it has been exposed to nuclear radiation, unless Xylem has been informed and appropriate actions have been agreed upon.

1.6 Spare parts



CAUTION:

Only use the manufacturer's original spare parts to replace any worn or faulty components. The use of unsuitable spare parts may cause malfunctions, damage, and injuries as well as void the warranty.

1.7 Warranty

For information about warranty, see the sales contract.

2 Transportation and Storage

2.1 Inspect the delivery

2.1.1 Inspect the package

1. Inspect the package for damaged or missing items upon delivery.
2. Note any damaged or missing items on the receipt and freight bill.
3. File a claim with the shipping company if anything is out of order.
If the product has been picked up at a distributor, make a claim directly to the distributor.

2.1.2 Inspect the unit

1. Remove packing materials from the product.
Dispose of all packing materials in accordance with local regulations.
2. Inspect the product to determine if any parts have been damaged or are missing.
3. If applicable, unfasten the product by removing any screws, bolts, or straps.
For your personal safety, be careful when you handle nails and straps.
4. Contact a sales representative if there is any issue.

2.2 Transportation guidelines

Precautions



DANGER: Crush Hazard

Moving parts can entangle or crush. Always disconnect and lock out power before servicing to prevent unexpected startup. Failure to do so could result in death or serious injury.

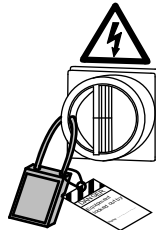

Position and fastening

The unit can be transported either horizontally or vertically. Make sure that the unit is securely fastened during transportation, and cannot roll or fall over.

2.2.1 Lifting

Always inspect the lifting equipment and tackle before starting any work.



WARNING: Crush Hazard

1) Always lift the unit by its designated lifting points. 2) Use suitable lifting equipment and ensure that the product is properly harnessed. 3) Wear personal protective equipment. 4) Stay clear of cables and suspended loads.

NOTICE:

Never lift the unit by its cables or hose.

2.3 Temperature ranges for transportation, handling and storage

Handling at freezing temperature

At temperatures below freezing, the product and all installation equipment, including the lifting gear, must be handled with extreme care.

Make sure that the product is warmed up to a temperature above the freezing point before starting up. Avoid rotating the impeller/propeller by hand at temperatures below the freezing point. The recommended method to warm the unit up is to submerge it in the liquid which will be pumped or mixed.

NOTICE:

Never use a naked flame to thaw the unit.

Unit in as-delivered condition

If the unit is still in the condition in which it left the factory - all packing materials are undisturbed - then the acceptable temperature range during transportation, handling and storage is: -50°C (-58°F) to $+60^{\circ}\text{C}$ ($+140^{\circ}\text{F}$).

If the unit has been exposed to freezing temperatures, then allow it to reach the ambient temperature of the sump before operating.

Lifting the unit out of liquid

The unit is normally protected from freezing while operating or immersed in liquid, but the impeller/propeller and the shaft seal may freeze if the unit is lifted out of the liquid into a surrounding temperature below freezing.

Follow these guidelines to avoid freezing damage:

1. Empty all pumped liquid, if applicable.
2. Check all liquids used for lubrication or cooling, both oil and water-glycol mixtures, for the presence of unacceptable amounts of water. Change if needed.

Water-glycol mixtures: Units equipped with an internal closed-loop cooling system are filled with a mixture of water and 30% glycol. This mixture remains a flowing liquid at temperatures down to -13°C (9°F). Below -13°C (9°F), the viscosity increases such that the glycol mixture will lose its flow properties. However, the glycol-water mixture will not solidify completely and thus cannot harm the product.

2.4 Storage guidelines

Storage location

The product must be stored in a covered and dry location free from heat, dirt, and vibrations.

NOTICE:

Protect the product against humidity, heat sources, and mechanical damage.

NOTICE:

Do not place heavy weights on the packed product.

Long-term storage

If the unit is stored more than six months, then the following apply:

- Before operating the unit after storage, it must be inspected with special attention to the seals and the cable entry.
- The impeller/propeller must be rotated every other month to prevent the seals from sticking together.

3 Product Description

3.1 Products included

Pump model	Standard	EX	MSHA	Drainage	Sludge
Ready 8, 2008.212	X			X	
Ready 8S, 2008.281	X				X

3.2 Pump design

The pump is submersible, and driven by an electric motor.

Intended use

The product is intended for moving waste water, sludge, raw and clean water. Always follow the limits given in [Technical Reference](#) on page 36. If there is a question regarding the intended use of the equipment, then contact a sales or authorized service representative before proceeding.



DANGER: Explosion/Fire Hazard

Special rules apply to installations in explosive or flammable atmospheres. Do not install the product or any auxiliary equipment in an explosive zone unless it is rated explosion-proof or intrinsically-safe. If the product is EN/ATEX-, MSHA- or FM-approved, then see the specific EX information in the Safety chapter before taking any further actions.

For information about pH, see [Technical Reference](#) on page 36.

Particle size

Version code 281: The pump can handle liquid containing particles that correspond to the pump housing inlet. The diameter of the pump housing inlet is 38 mm (1.5 in).

Version code 212: The pump can handle liquid containing particles that correspond to the holes in the strainer.

Number of holes	Hole dimensions
Version code 212: 96	11×5 mm (0.43×0.2 in)

Pressure class

MT Medium head

Impeller type

Version code 212: B Wear resistant
Version code 281: D Sludge

3.3 Monitoring equipment

The following applies to the monitoring equipment of the pump:

- The stator incorporates thermal contacts connected in series that activate the alarm at overtemperature.
- The thermal contacts open at 135°C (275°F).

3.3.1 Level regulators

About level regulators

Starting and stopping the pump at different water levels can be manual or automatic. If automatic start and stop is required, a level regulator can be ordered (as an option). The option is only available for standard pumps.

Features

Below are some of the features of the level regulators:

- The level regulator can be set at different operating levels by adjusting the length of cable.
- A clamping bracket situated at the lifting handle holds the level regulator cable in place.
- If continuous pumping is required, the level regulator can be placed in a special rubber bracket on the discharge connection to eliminate the level regulator function.

Illustration

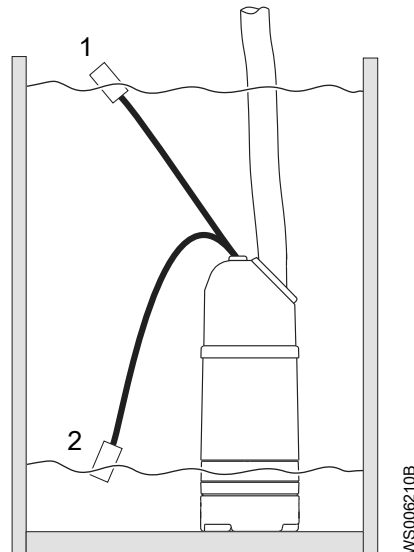

1. On
2. Off

Figure 1: The functionality of the level regulator

3.4 The data plate

Introduction

The data plate is located on the main body of the pump. The data plate lists key product specifications.

The data plate

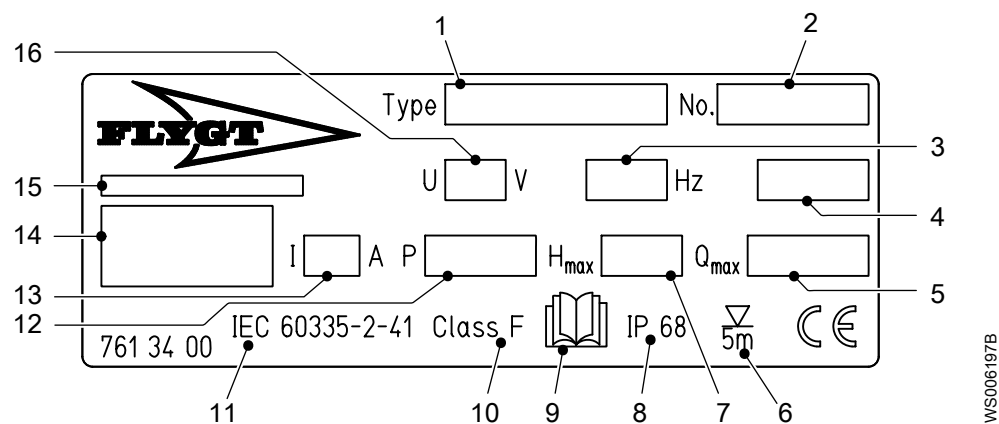

1. Pump model
2. Serial number
3. Phase; type of current; frequency
4. Product weight
5. Maximum capacity
6. Maximum submergence
7. Maximum head
8. Degree of protection

- 9. Read installation manual
- 10. Thermal class
- 11. International standard
- 12. Rated shaft power
- 13. Rated current
- 14. Manufacturer
- 15. Country of origin
- 16. Rated voltage

3.5 Product denomination

Reading instruction

In this section, code characters are illustrated accordingly:

X = letter

Y = digit

The different types of codes are marked up with a, b and c. Code parameters are marked up with numbers.

Codes and parameters

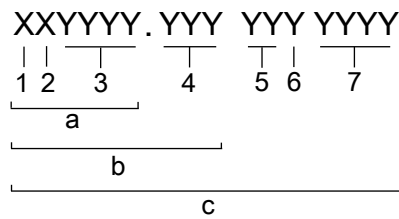

WS006265B

Type of Callout	Number	Indication
Type of code	a	Sales denomination
	b	Product code
	c	Serial number
Parameter	1	Hydraulic end
	2	Type of installation
	3	Sales code
	4	Version
	5	Production year
	6	Production cycle
	7	Running number

4 Installation

4.1 Install the pump

Before starting work, make sure that the safety instructions in the chapter [Introduction and Safety](#) on page 3 have been read and understood.



DANGER: Electrical Hazard

Before starting work on the unit, make sure that the unit and the control panel are isolated from the power supply and cannot be energized. This applies to the control circuit as well.

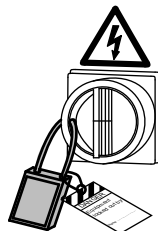

DANGER: Inhalation Hazard

Before entering the work area, make sure that the atmosphere contains sufficient oxygen and no toxic gases.

Hazardous atmospheres



DANGER: Explosion/Fire Hazard

Special rules apply to installations in explosive or flammable atmospheres. Do not install the product or any auxiliary equipment in an explosive zone unless it is rated explosion-proof or intrinsically-safe. If the product is EN/ATEX-, MSHA- or FM-approved, then see the specific EX information in the Safety chapter before taking any further actions.



WARNING: Explosion/Fire Hazard

Do not install CSA-approved products in locations that are classified as hazardous in the National Electric Code(TM), ANSI/NFPA 70-2005.

Authority regulation

Vent the tank of a sewage station in accordance with local plumbing codes.

Sedimentation prevention

In order to avoid sedimentation when the pumped liquid contains solid particles, the velocity of the liquid in the discharge line must exceed a certain value. Choose applicable minimum velocity from the table, and choose proper dimension of the discharge line accordingly.

Mixture	Minimum velocity, meter per second (feet per second)
Water + coarse gravel	4 (13)
Water + gravel	3.5 (11)
Water + sand, particle size <0.6 mm (0.024 in)	2.5 (8.2)
Water + sand, particle size <0.1 mm (0.004 in)	1.5 (4.9)

For more permanent installations with a heavily contaminated pumped liquid, a settling pump-sump is recommended.

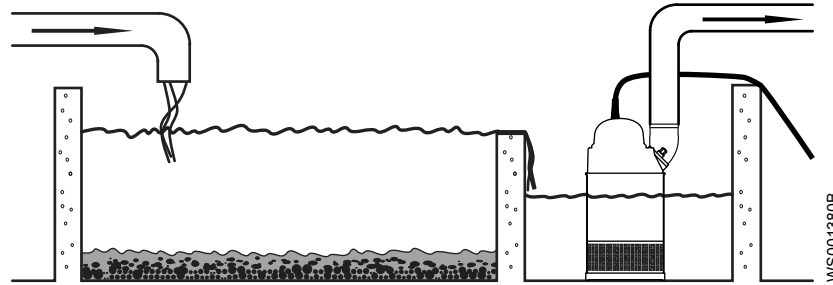
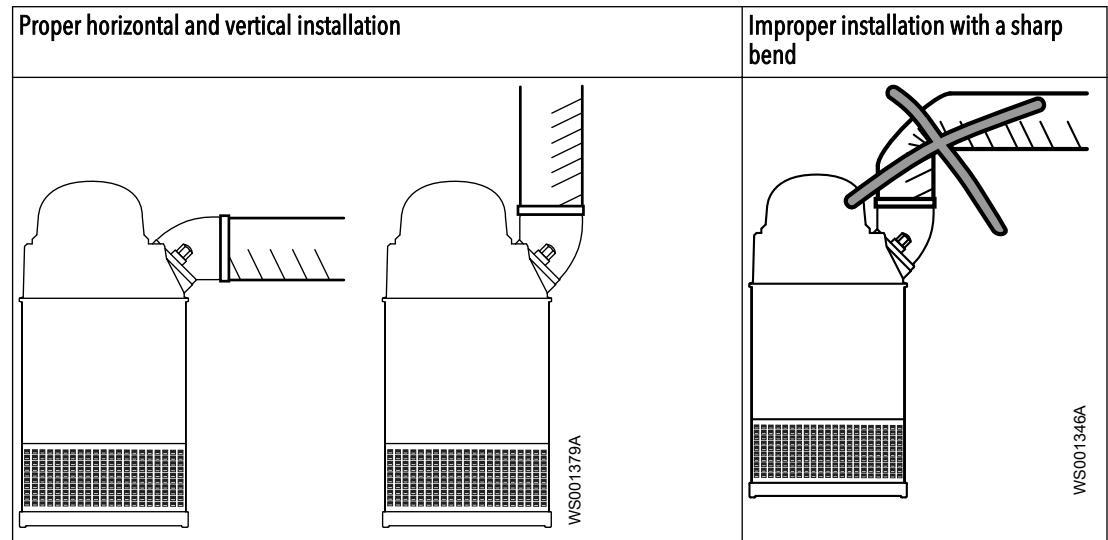

Figure 2: Settling pump-sump

Discharge line requirements

The discharge line can be run vertically or horizontally, but must be without sharp bends.



Fasteners

- Only use fasteners of the correct size and material.
- Replace all corroded or damaged fasteners.
- Make sure that all the fasteners are correctly tightened and that there are no missing fasteners.

4.1.1 Install with S-installation

In the S-installation, the pump is transportable and intended to operate either completely or partially submerged in the pumped liquid. The pump is equipped with a connection for hose or pipe.

These requirements and instructions only apply when the installation is made according to the dimensional drawing.

1. Run the cable so that it has no sharp bends. Make sure that it is not pinched, and cannot be sucked into the pump inlet.
2. Connect the discharge line.
3. Lower the pump into the sump.
4. Place the pump on the base and make sure it cannot fall over or sink.

Alternatively, the pump can be suspended with a lifting chain just above the sump bottom. Make sure that the pump cannot rotate at start-up or during operation.

5. Connect the motor cable and the starter and monitoring equipment according to the separate instructions.

Make sure that the impeller rotation is correct. For more information, see [Check the impeller rotation](#) on page 17.

4.2 Make the electrical connections

General precautions



DANGER: Electrical Hazard

Before starting work on the unit, make sure that the unit and the control panel are isolated from the power supply and cannot be energized. This applies to the control circuit as well.

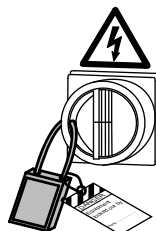

WARNING: Electrical Hazard

Risk of electrical shock or burn. A certified electrician must supervise all electrical work. Comply with all local codes and regulations.



WARNING: Electrical Hazard

There is a risk of electrical shock or explosion if the electrical connections are not correctly carried out, or if there is fault or damage on the product. Visually inspect equipment for damaged cables, cracked casings or other signs of damage. Make sure that electrical connections have been correctly made.



WARNING: Crush Hazard

Risk of automatic restart.



CAUTION: Electrical Hazard

Prevent cables from becoming sharply bent or damaged.

NOTICE:

Leakage into the electrical parts can cause damaged equipment or a blown fuse. Keep the cable ends dry at all times.

Requirements

These general requirements apply for electrical installation:

- The supply authority must be notified before installing the pump if it will be connected to the public mains. When the pump is connected to the public power supply, it may cause flickering of incandescent lamps when started.
- The mains voltage and frequency must agree with the specifications on the data plate. If the pump can be connected to different voltages, then the connected voltage is specified by a yellow sticker close to the cable entry.
- The fuses and circuit breakers must have the proper rating, and the pump overload protection (motor protection breaker) must be connected and set to the rated current

according to the data plate and if applicable the cable chart. The starting current in direct-on-line start can be up to six times higher than the rated current.

- The fuse rating and the cables must be in accordance with the local rules and regulations.
- If intermittent operation is prescribed, then the pump must be provided with monitoring equipment supporting such operation.
- The thermal contacts/thermistors must be in use.

Cables

These are the requirements to follow when you install cables:

- The cables must be in good condition, not have any sharp bends, and not be pinched.
- The cables must not be damaged and must not have indentations or be embossed (with markings, etc.) at the cable entry.
- The minimum bending radius must not be below the accepted value.
- If using a cable which has been used before, a short piece must be peeled off when refitting it so that the cable entry seal sleeve does not close around the cable at the same point again. If the outer sheath of the cable is damaged, then replace the cable. Contact a sales or authorized service representative.
- The voltage drop in long cables must be taken into account. The drive unit's rated voltage is the voltage measured at the cable connection point in the pump.
- For SUBCAB® cables, the twisted pair copper foil must be trimmed.
- All unused conductors must be insulated.

Grounding (earthing)

Grounding (earthing) must be done in compliance with all local codes and regulations.



DANGER: Electrical Hazard

All electrical equipment must be grounded (earthed). Test the ground (earth) lead to verify that it is connected correctly and that the path to ground is continuous.



WARNING: Electrical Hazard

If the power cable is jerked loose, then the ground (earth) conductor must be the last conductor to come loose from its terminal. Make sure that the ground (earth) conductor is longer than the phase conductors at both ends of the cable.



WARNING: Electrical Hazard

Risk of electrical shock or burn. You must connect an additional ground- (earth-) fault protection device to the grounded (earthed) connectors if persons are likely to come into contact with liquids that are also in contact with the pump or pumped liquid.

Ground (earth) conductor length

The ground (earth) conductor must be 180 mm (7.1 in) longer than the phase conductors in the junction box of the unit.

Check the ground (earth) continuity

NOTICE:

The two earth (ground) conductors in the pump are connected via the same conductor to ground (earth)

Check the ground (earth) continuity.

Measure between the ground (earth) conductor in the motor cable and one of the screws securing the strainer.

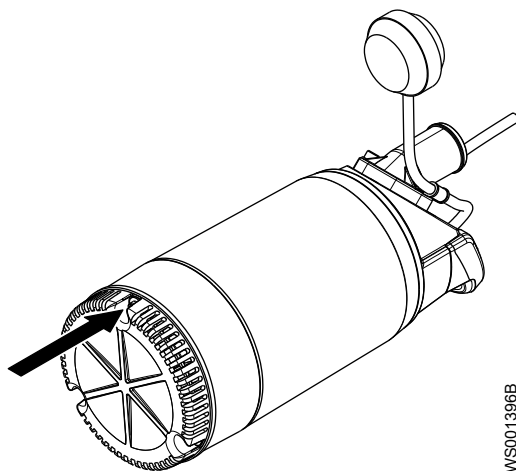

4.2.1 Connect the motor cable to the pump

NOTICE:

Leakage into the electrical parts can cause damaged equipment or a blown fuse. Keep the end of the motor cable dry at all times.

1. Check the data plate to see which connections are required for the power supply.
2. Connect the motor cable conductors, including ground (earth) , to the terminal or starter unit.
3. Make sure that the pump is correctly connected to ground (earth) .
4. Firmly tighten the cable entry into its bottom-most position.

The seal sleeve and the washers must conform to the outside diameter of the cables.

DANGER: Explosion/Fire Hazard

Special rules apply to installations in explosive or flammable atmospheres. Do not install the product or any auxiliary equipment in an explosive zone unless it is rated explosion-proof or intrinsically-safe. If the product is EN/ATEX-, MSHA- or FM-approved, then see the specific EX information in the Safety chapter before taking any further actions.



4.2.2 Cable charts

Connection locations

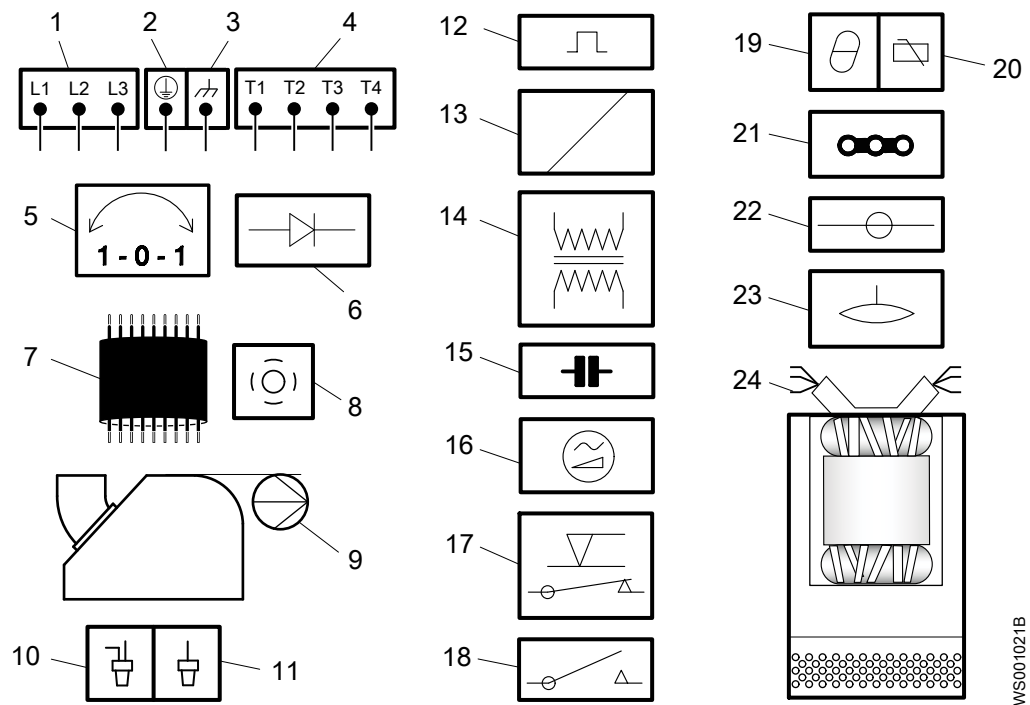

1	Starter equipment and main leads (L1, L2, L3)	13	Coil
2	Ground (earth)	14	Transformer
3	Functional ground	15	Capacitor
4	Control leads (T1, T2, T3, T4)	16	Softstarter
5	Phase shifter	17	Level regulator
6	Diode	18	Contacting, start relay or thermal relay
7	Motor cable	19	Thermal detector in stator
8	Screen	20	Thermal detector in main bearing
9	Pump	21	Jumper
10	Crimp connection	22	Terminal board, terminal plate
11	Crimp isolation	23	Leakage sensor
12	Motor protector	24	Stator leads (U1, U2, U5, U6, V1, V2, V5, V6, W1, W2, W5, W6, Z1, Z5, Z6)

Color code standard

Code	Description
BN	Brown
BK	Black
WH	White
OG	Orange
GN	Green
GNYE	Green-Yellow
RD	Red
GY	Grey
BU	Blue

Code	Description
YE	Yellow

Motor cable and starter unit connection to the terminal board

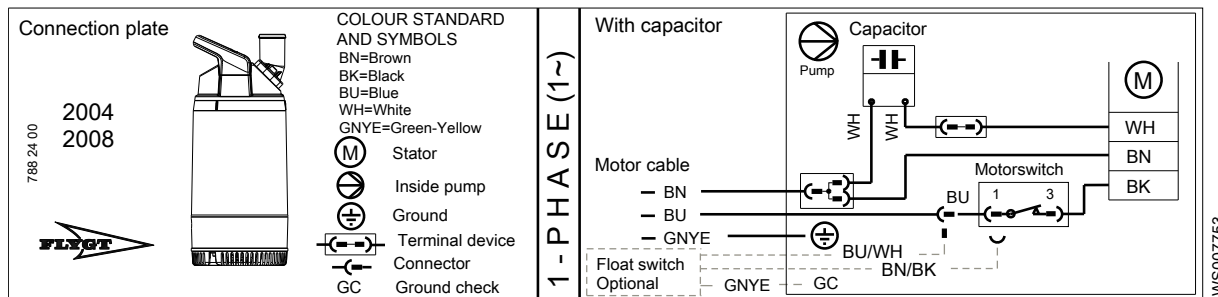

4.3 Check the impeller rotation



CAUTION: Crush Hazard

The starting jerk can be powerful. Make sure nobody is close to the unit when it is started.

Check the direction of rotation each time the cable has been re-connected and after phase or total supply failure.

1. Start the motor.
2. Stop the motor.
3. Check that the impeller rotates in the correct direction.

The correct direction of impeller rotation is clockwise when you look at the pump from above. When started, the pump will react in the opposite direction to the impeller rotation.

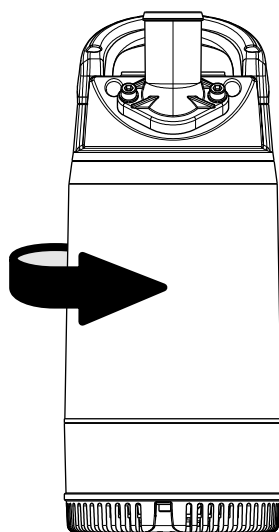

WS001398B

Figure 3: Start reaction

4. If the impeller rotates in the wrong direction, then do the following:
 - If the motor has a 1-phase connection, then contact a sales or authorized service representative.

5 Operation

5.1 Precautions

Before taking the unit into operation, check the following:

- All recommended safety devices are installed.
- The cable and cable entry have not been damaged.
- All debris and waste material has been removed.

NOTICE:

Never operate the pump with the discharge line blocked, or the discharge valve closed.



WARNING: Crush Hazard

Risk of automatic restart.

Distance to wet areas



WARNING: Electrical Hazard

Risk of electrical shock or burn. You must connect an additional ground- (earth-) fault protection device to the grounded (earthed) connectors if persons are likely to come into contact with liquids that are also in contact with the pump or pumped liquid.



CAUTION: Electrical Hazard

Risk of electrical shock or burn. The equipment manufacturer has not evaluated this unit for use in swimming pools. If used in connection with swimming pools then special safety regulations apply.

Noise level

NOTICE:

The sound power level of the product is lower than 70 dB(A). However, in some installations the resulting sound pressure level may exceed 70 dB(A) at certain operating points on the performance curve. Make sure that you understand the noise level requirements in the environment where the product is installed. Failure to do so may result in hearing loss or violation of local laws.

Single phase pumps



WARNING: Explosion/Fire Hazard

The start capacitor is not designed for many repeated start cycles in a short time. Always wait at least 15 seconds between starting attempts. Maximum allowed: 30 starts per hour.

5.2 Start the pump



CAUTION: Crush Hazard

The starting jerk can be powerful. Make sure nobody is close to the unit when it is started.

NOTICE:

Make sure that the rotation of the impeller is correct. For more information, see Check the impeller rotation.

1. Inspect the pump. Check that there is no physical damage to the pump or cables.
2. Check the oil level in the oil housing.
3. Remove the fuses or open the circuit breaker, and check that the impeller can rotate freely.



WARNING: Crush Hazard

Never put your hand into the pump housing.

4. Check that the monitoring equipment (if any) works.
5. Check that the impeller rotation is correct.
6. Start the pump.

5.3 Clean the pump

The pump must be cleaned if it has been running in very dirty water. If clay, cement or other similar dirt is left in the pump it may clog the impeller and seal, preventing the pump from working.

Let the pump run for a while in clean water, or flush it through the discharge connection.

6 Maintenance

Precautions

Before starting work, make sure that the safety instructions in the chapter [Introduction and Safety](#) on page 3 have been read and understood.



DANGER: Crush Hazard

Moving parts can entangle or crush. Always disconnect and lock out power before servicing to prevent unexpected startup. Failure to do so could result in death or serious injury.

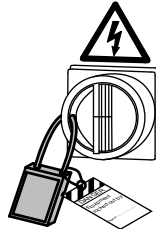

WARNING: Biological Hazard

Infection risk. Rinse the unit thoroughly with clean water before working on it.



CAUTION: Crush Hazard

Make sure that the unit cannot roll or fall over and injure people or damage property.

Make sure that you follow these requirements:

- Check the explosion risk before you weld or use electrical hand tools.
- Allow all system and pump components to cool before you handle them.
- Make sure that the product and its components have been thoroughly cleaned.
- Make sure that the work area is well-ventilated before you open any vent or drain valves, remove any plugs, or disassemble the unit.
- Do not open any vent or drain valves or remove any plugs while the system is pressurized. Make sure that the pump is isolated from the system and that pressure is relieved before you disassemble the pump, remove plugs, or disconnect piping.

Ground continuity verification

A ground (earth) continuity test must always be performed after service.

Maintenance guidelines

During the maintenance and before reassembly, always remember to perform these tasks:

- Clean all parts thoroughly, particularly O-ring grooves.
- Change all O-rings, gaskets, and seal washers.
- Lubricate all springs, screws, O-rings with grease.

During the reassembly, always make sure that existing index markings are in line.

The reassembled drive unit must always be insulation-tested and the reassembled pump must always be test-run before normal operation.

6.1 Torque values

All screws and nuts must be lubricated to achieve correct tightening torque. Screws that are screwed into stainless steel must have the threads coated with suitable lubricants to prevent seizing.

If there is a question regarding the tightening torques, then contact a sales or authorized service representative.

Screws and nuts

Table 1: Stainless steel, A2 and A4, torque Nm (ft-lbs)

Property class	M4	M5	M6	M8	M10	M12	M16	M20	M24	M30
50	1.0 (0.74)	2.0 (1.5)	3.0 (2.2)	8.0 (5.9)	15 (11)	27 (20)	65 (48)	127 (93.7)	220 (162)	434 (320)
70, 80	2.7 (2)	5.4 (4)	9.0 (6.6)	22 (16)	44 (32)	76 (56)	187 (138)	364 (268)	629 (464)	1240 (915)
100	4.1 (3)	8.1 (6)	14 (10)	34 (25)	66 (49)	115 (84.8)	248 (183)	481 (355)	–	–

Table 2: Steel, torque Nm (ft-lbs)

Property class	M4	M5	M6	M8	M10	M12	M16	M20	M24	M30
8.8	2.9 (2.1)	5.7 (4.2)	9.8 (7.2)	24 (18)	47 (35)	81 (60)	194 (143)	385 (285)	665 (490)	1310 (966.2)
10.9	4.0 (2.9)	8.1 (6)	14 (10)	33 (24)	65 (48)	114 (84)	277 (204)	541 (399)	935 (689)	1840 (1357)
12.9	4.9 (3.6)	9.7 (7.2)	17 (13)	40 (30)	79 (58)	136 (100)	333 (245)	649 (480)	1120 (825.1)	2210 (1630)

Hexagon screws with countersunk heads

For hexagon socket head screws with countersunk head, maximum torque for all property classes must be 80% of the values for property class 8.8 above.

6.2 Service

Regular service of the pump ensures more reliable operation.

Inspection

The pump should be inspected at least twice a year, more frequently under severe operating conditions.

Screw tightening

During assembly or service of the pumps we recommend that the screws be tightened to approximately 6–8 Nm (4.5–6 ft-lbs). The tightening torque ensures that the parts are correctly fastened and that the pumps will operate as intended.

NOTICE:

Make sure that the oil-plug and securing screws for the strainer or the pump housing are not tightened too hard.

To maintain screw tightness, use some mineral oil on all non-stainless steel screws.

When using stainless steel screws on stainless steel parts, apply Aral Degol GS 460 or National Chemseal Thread-Eze lubricant in order to prevent the screws from seizing.

6.3 Change the oil

A paraffin oil with viscosity close to ISO VG32 is recommended. The pump is delivered from the factory with this type of oil. Examples of suitable oil types are the following:

- Statoil MedicWay 32™
- BP Enerpar M 004™
- Shell Ondina 927™
- Shell Ondina X430™

In applications where poisonous properties are of less concern, a mineral oil with viscosity up to ISO VG32 can be used.

Empty the oil

1. Lay the pump on its side.
Lock the pump with supports to prevent it from rolling over.
2. Remove the oil screw.



CAUTION: Compressed Gas Hazard

Air inside the chamber may cause parts or liquid to be propelled with force. Be careful when opening. Hold a rag over the plug to prevent liquid from spraying out.

3. Turn the pump so that the oil hole faces downwards and let the oil run out into a container.

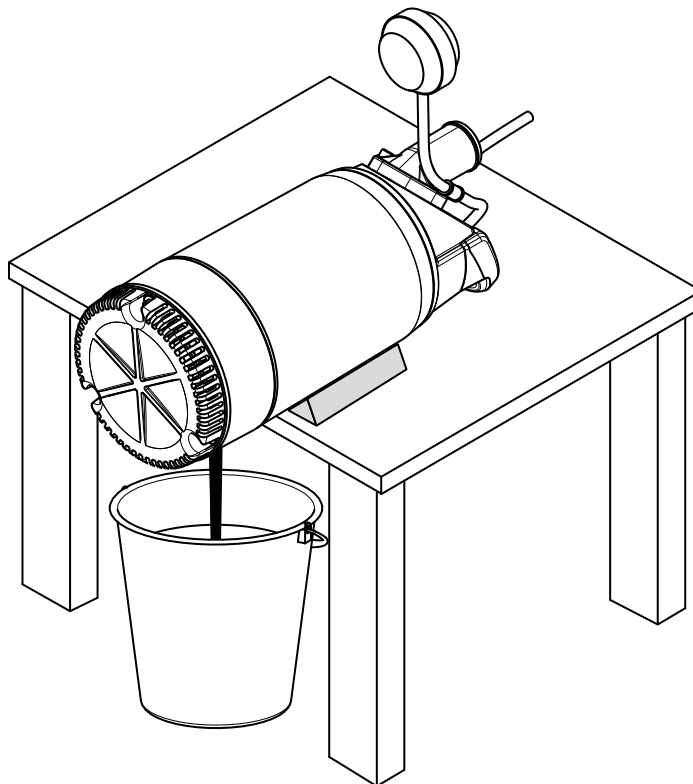

WS002100A

Fill with oil

1. Replace the oil screw O-ring.
2. Turn the pump so that the oil hole faces upwards and fill with new oil.
Quantity: 0.17 L (0.18 qt)
3. Put the oil screw back and tighten it.

6.4 Replace the impeller

6.4.1 Remove the impeller, drainage version



CAUTION: Cutting Hazard

Worn parts can have sharp edges. Wear protective clothing.

1. Remove the strainer.

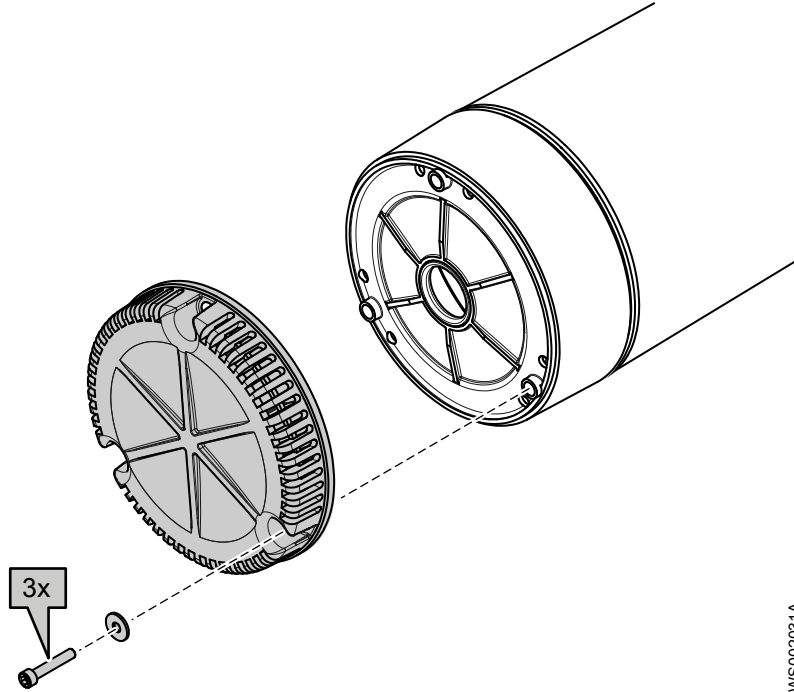

2. Remove the diffuser.

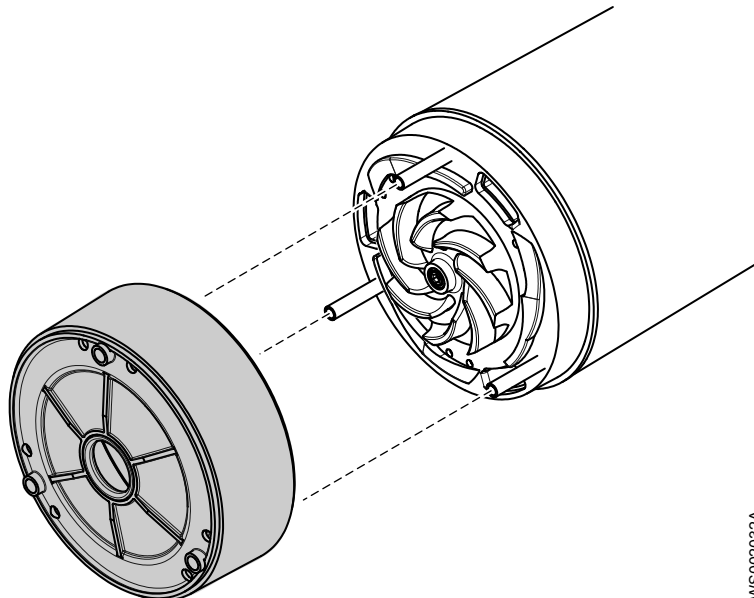

3. Remove the impeller:
 - a) Remove the impeller screw and washer.
 - b) Pull off the impeller.

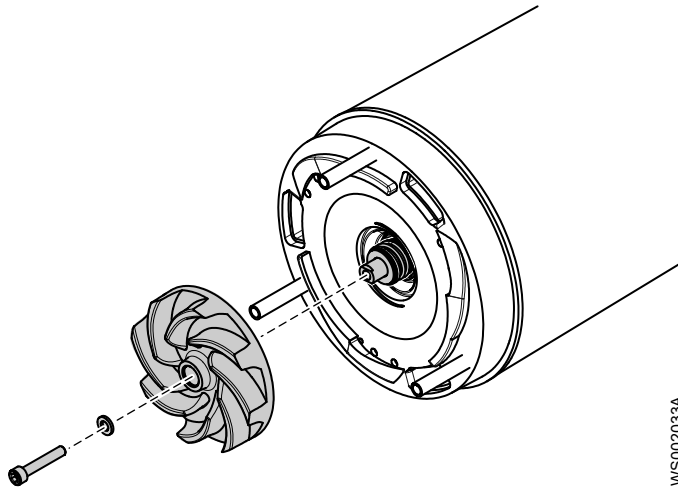

6.4.2 Remove the impeller, sludge version



CAUTION: Cutting Hazard

Worn parts can have sharp edges. Wear protective clothing.

1. Remove the pump housing unit.

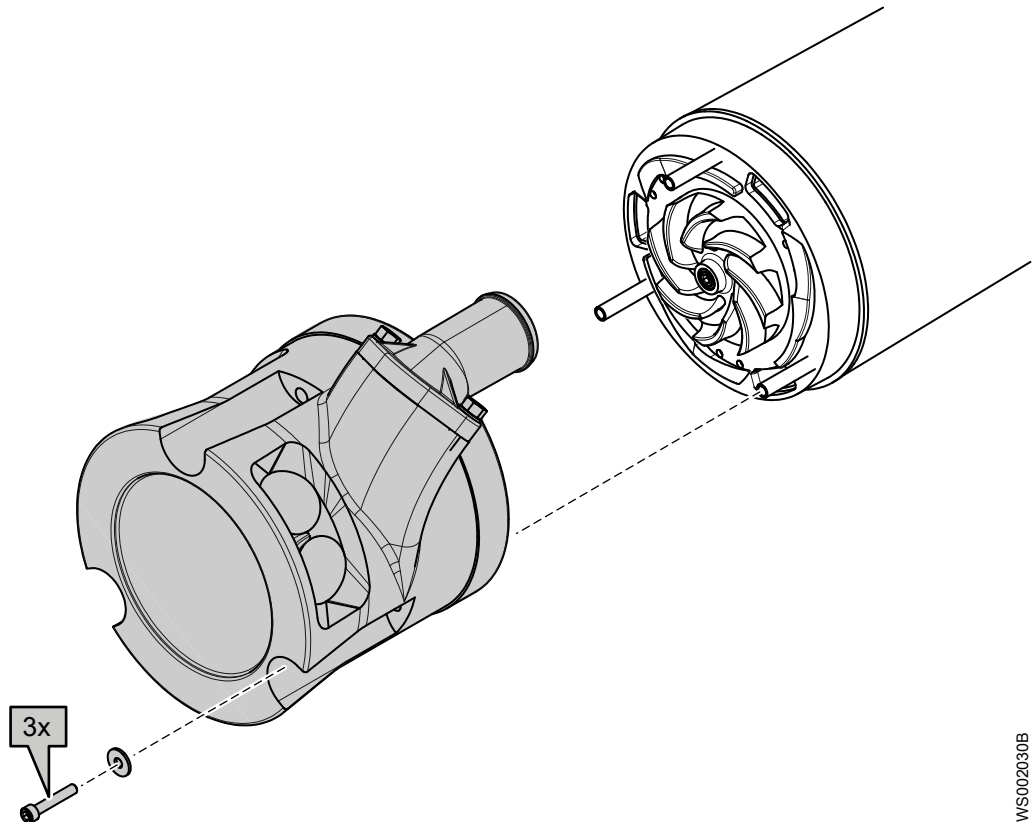

2. Remove the impeller:
 - a) Remove the impeller screw and washer.
 - b) Pull off the impeller.

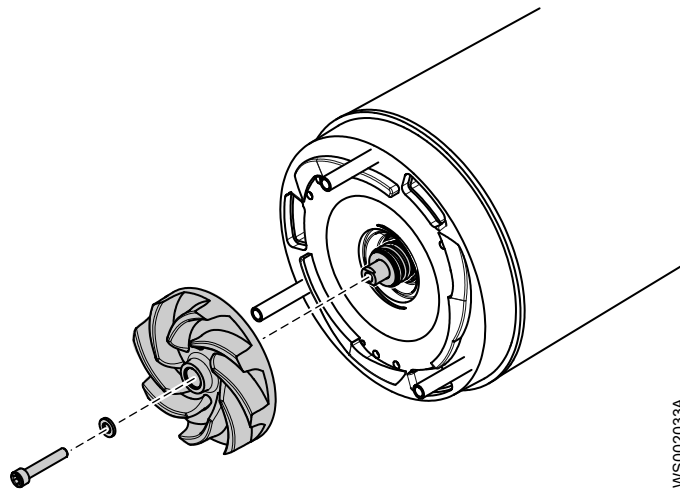

6.4.3 Install the impeller, drainage version

1. Prepare the shaft. Polish off any flaws with a fine emery cloth.
The end of the shaft must be clean and free from burrs.
2. Check that the impeller screw is clean and easy to screw into the shaft end.
This is to prevent the shaft from rotating with the impeller screw.
3. Fasten the impeller:
 - a) Place the washer on the impeller screw.
 - b) Mount the impeller.
Make sure that the impeller hub disk center is aligned with the slotted shaft end.

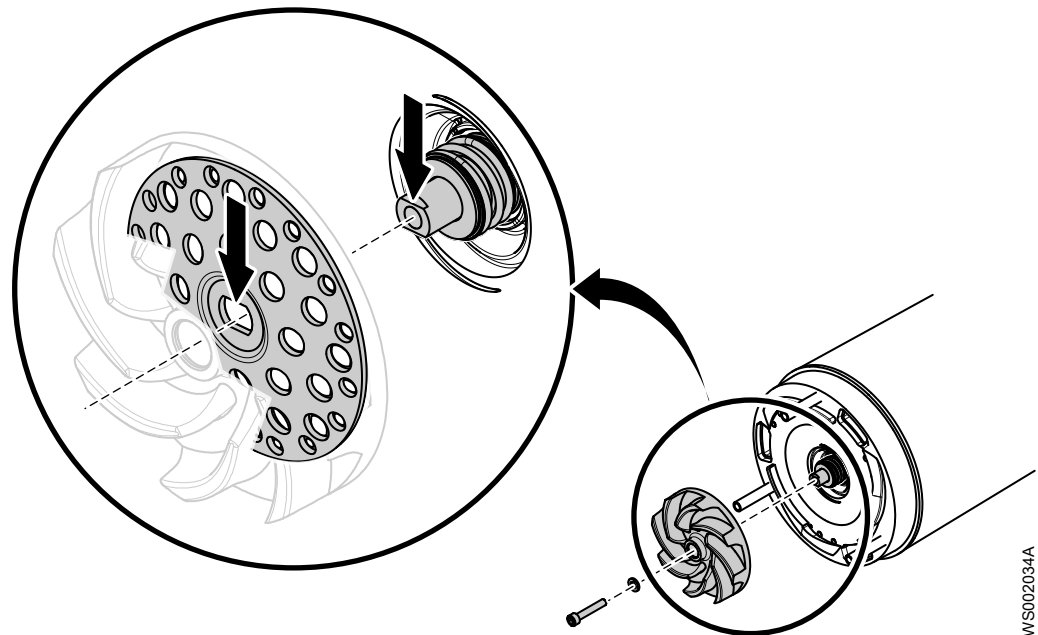

- c) Tighten the impeller screw.
Tightening torque: 9.3 Nm (6.9 ft-lb)
 - d) Check that the impeller can rotate freely.
4. Mount the diffuser unit.

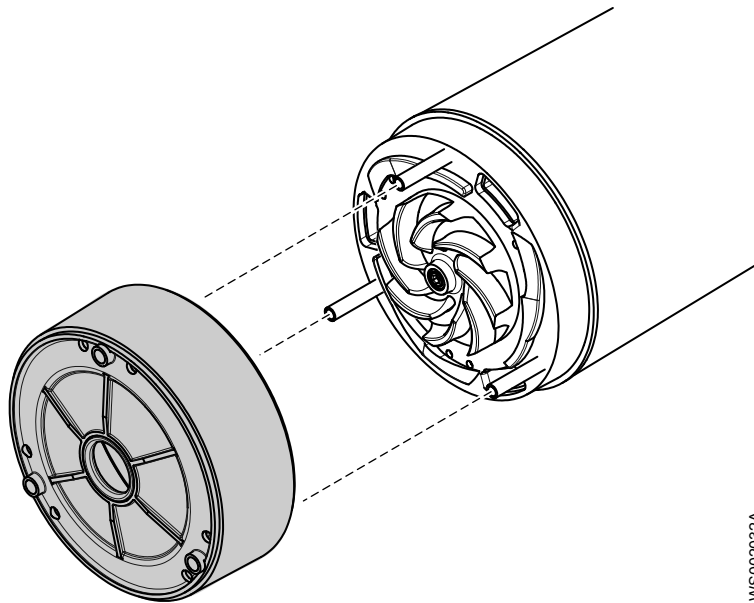

WS002032A

5. Mount the strainer and the screws.
Tightening torque: 9.3 Nm (6.9 ft-lb)

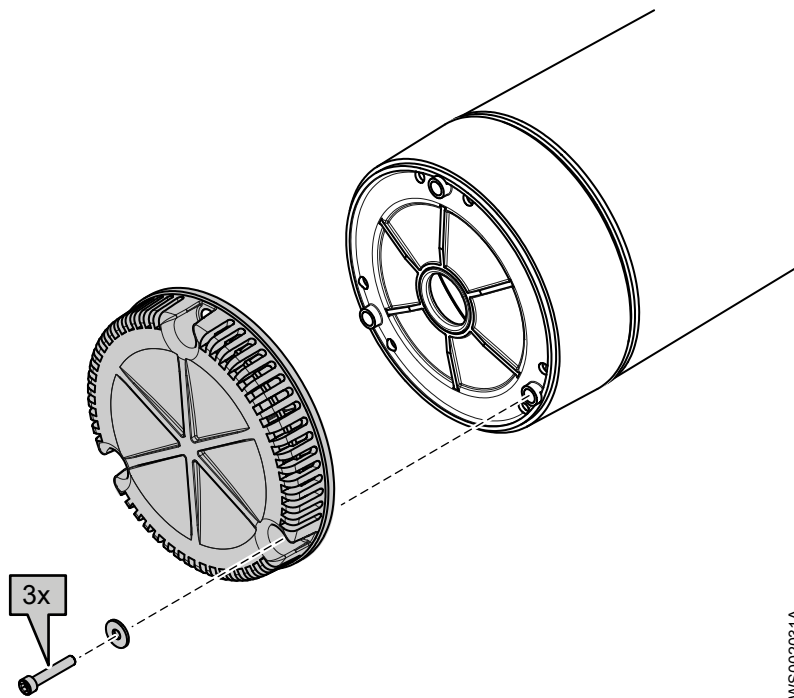

WS002031A

6.4.4 Install the impeller, sludge version

1. Prepare the shaft. Polish off any flaws with a fine emery cloth.
The end of the shaft must be clean and free from burrs.
2. Check that the impeller screw is clean and easy to screw into the shaft end.
This is to prevent the shaft from rotating with the impeller screw.
3. Fasten the impeller:
 - a) Place the washer on the impeller screw.
 - b) Mount the impeller.
Make sure that the impeller hub disk center is aligned with the slotted shaft end.

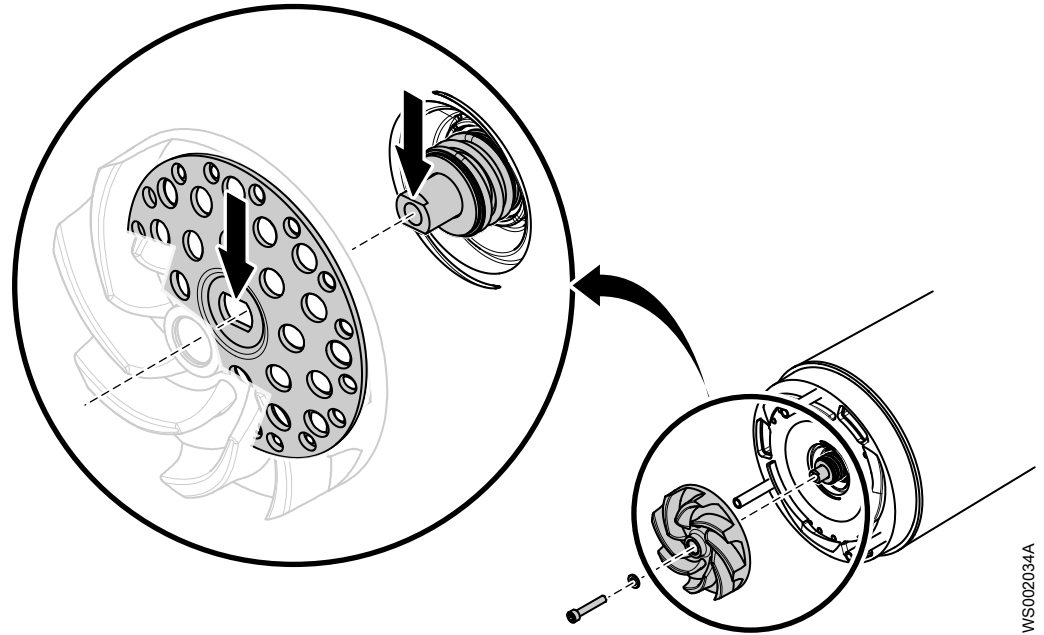

- c) Tighten the impeller screw.
Tightening torque: 9.3 Nm (6.9 ft-lbs)
 - d) Check that the impeller can rotate freely.
4. Mount the pump housing unit.

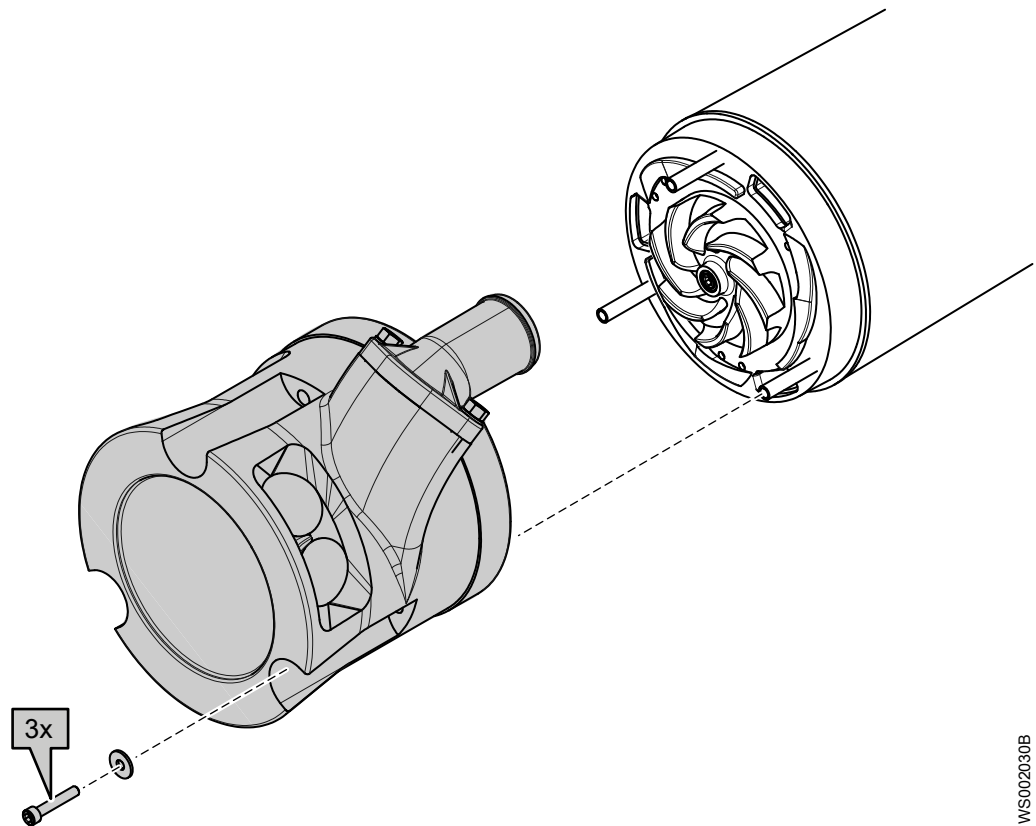

5. Tighten the screw(s).
Tightening torque: 9.3 Nm (6.9 ft-lbs)

6.5 Replace the motor cable

6.5.1 Remove the motor cable

1. Loosen the cable entry.

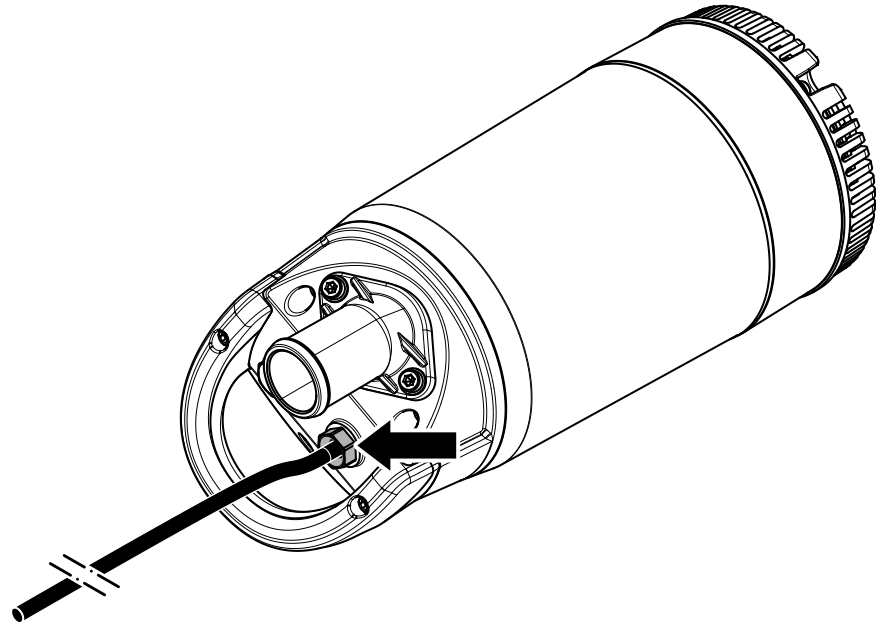

WS003053A

2. Remove the pump top.

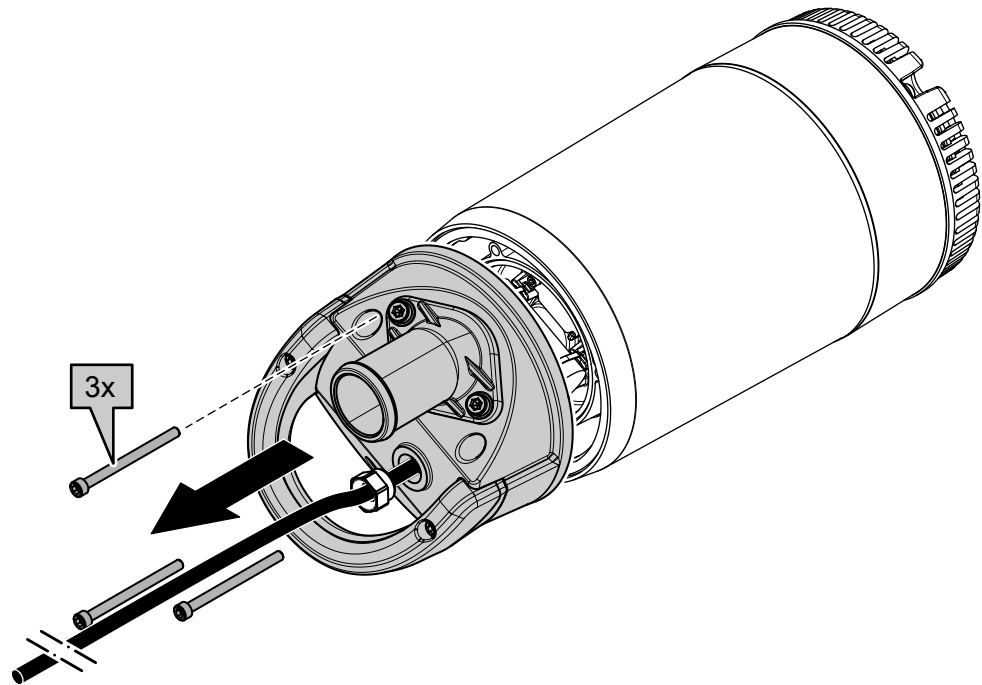

WS003054A

3. Disconnect the motor cable from the terminals:
 - a) Disconnect the power lead(s).
 - b) Disconnect the ground (earth) lead(s).
4. Remove the motor cable.

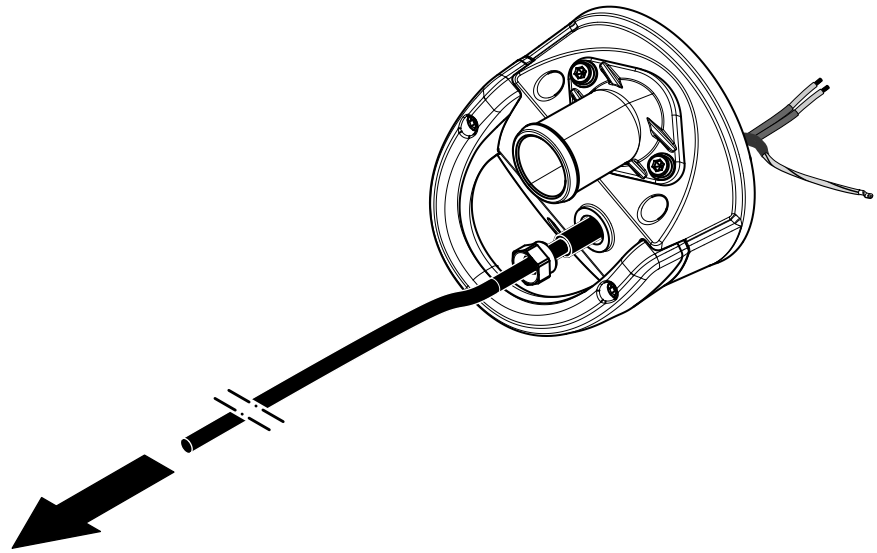

W5003055A

6.5.2 Install the motor cable

1. Pull the cable through the pump top.

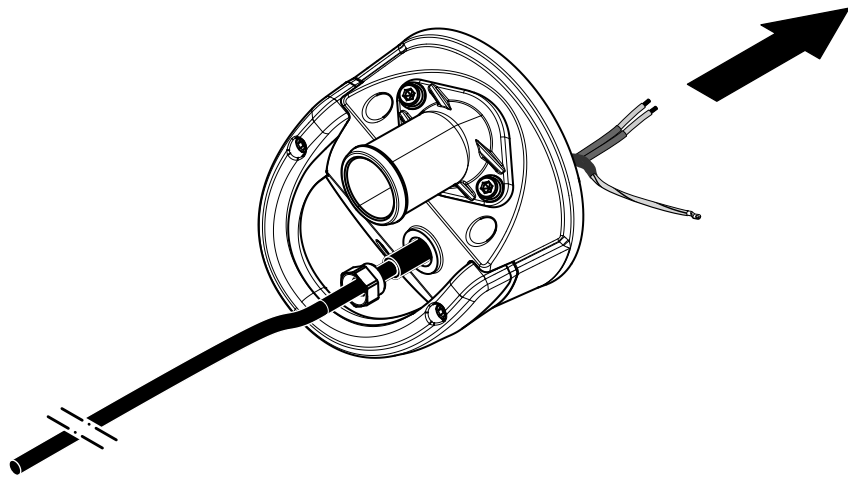

W5003057A

2. Connect the terminals. See [Make the electrical connections](#) on page 13.
If the cable is damaged, then cut off the damaged part and install new terminals.
 - a) Connect the ground (earth) lead(s).
 - b) Connect the power lead(s).
3. Install the pump top.

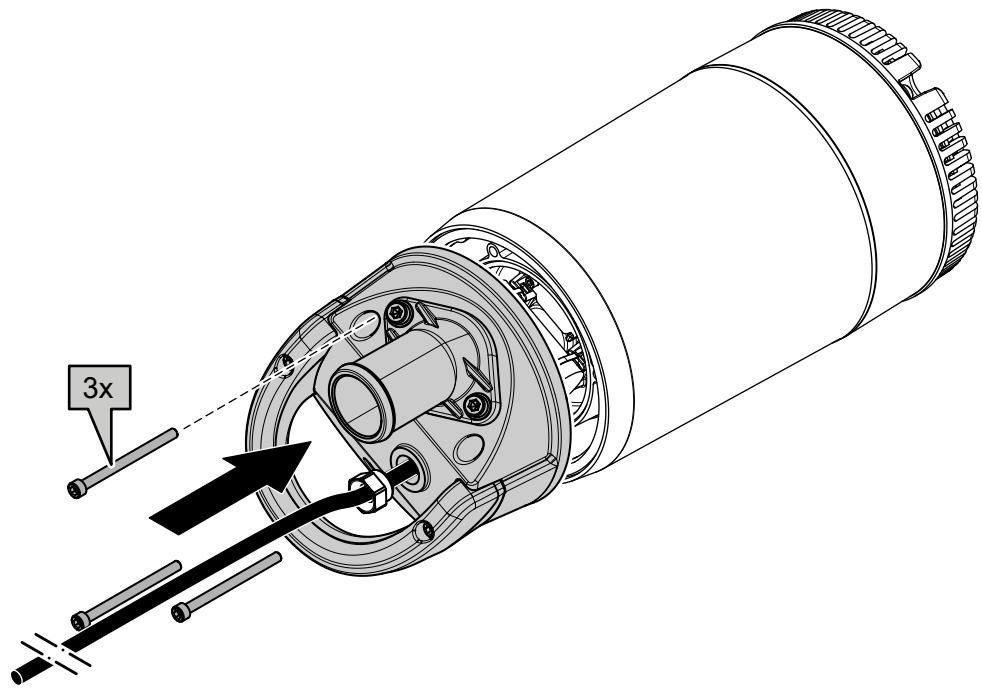

4. Tighten the cable entry.
Make sure that it bottoms out.

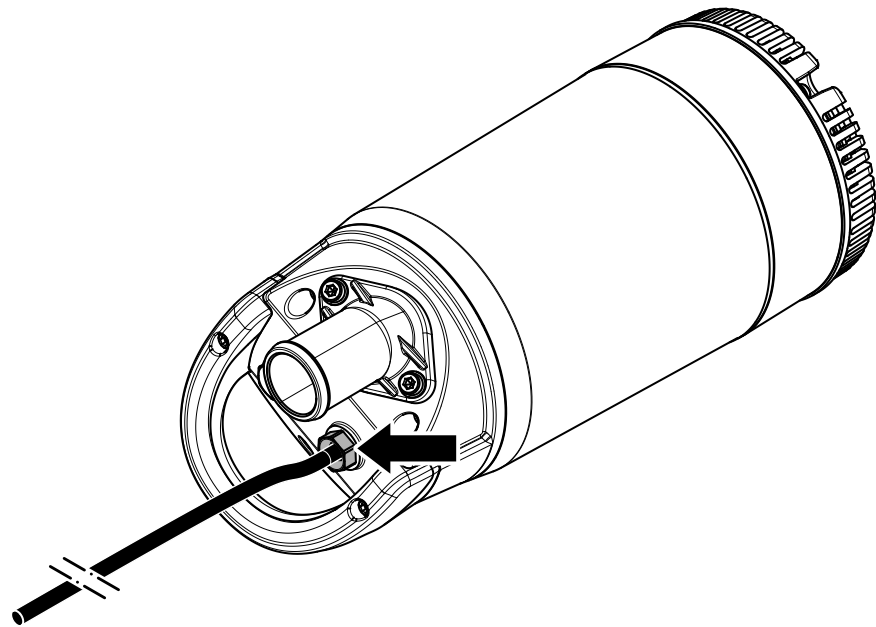

WS003056A

WS003053A

7 Troubleshooting

Introduction



DANGER: Electrical Hazard

Troubleshooting a live control panel exposes personnel to hazardous voltages. Electrical troubleshooting must be done by a qualified electrician.

Follow these guidelines when troubleshooting:

- Disconnect and lock out the power supply except when conducting checks that require voltage.
- Make sure that no one is near the unit when the power supply is reconnected.
- When troubleshooting electrical equipment, use the following:
 - Universal instrument multimeter
 - Test lamp (continuity tester)
 - Wiring diagram

7.1 The pump does not start



DANGER: Crush Hazard

Moving parts can entangle or crush. Always disconnect and lock out power before servicing to prevent unexpected startup. Failure to do so could result in death or serious injury.

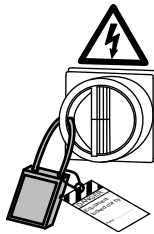

NOTICE:

Do NOT override the motor protection repeatedly if it has tripped. Doing so may result in equipment damage.

Cause	Remedy
An alarm signal has been triggered on the control panel.	Check that: <ul style="list-style-type: none"> • The impeller rotates freely. • The sensor indicators do not indicate an alarm. • The overload protection is not tripped.
The pump does not start automatically, but can be started manually.	Check that: <ul style="list-style-type: none"> • The start level regulator is functioning. Clean or replace if necessary. • All connections are intact. • The relay and contactor coils are intact. • The control switch (Man/Auto) makes contact in both positions. Check the control circuit and functions.

Cause	Remedy
The installation is not receiving voltage.	Check that: <ul style="list-style-type: none"> • The main power switch is on. • There is control voltage to the start equipment. • The fuses are intact. • There is voltage in all phases of the supply line. • All fuses have power and that they are securely fastened to the fuse holders. • The overload protection is not tripped. • The motor cable is not damaged.
The impeller is stuck.	Clean: <ul style="list-style-type: none"> • The impeller • The sump in order to prevent the impeller from clogging again.

If the problem persists, then contact a sales or authorized service representative.

Always state the serial number of the product, see [Product Description](#) on page 8.

7.2 The pump does not stop when a level sensor is used



DANGER: Crush Hazard

Moving parts can entangle or crush. Always disconnect and lock out power before servicing to prevent unexpected startup. Failure to do so could result in death or serious injury.

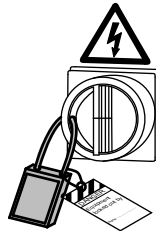

Cause	Remedy
The pump is unable to empty the sump to the stop level.	Check that: <ul style="list-style-type: none"> • There are no leaks from the piping and/or discharge connection. • The impeller is not clogged. • The non-return valve(s) are functioning properly. • The pump has adequate capacity. For information: Contact a sales or authorized service representative.
There is a malfunction in the level-sensing equipment.	<ul style="list-style-type: none"> • Clean the level regulators. • Check the functioning of the level regulators. • Check the contactor and the control circuit. • Replace all defective items.
The stop level is set too low.	Raise the stop level.

If the problem persists, then contact a sales or authorized service representative.

Always state the serial number of the product, see [Product Description](#) on page 8.

7.3 The pump starts-stops-starts in rapid sequence

Cause	Remedy
The pump starts due to back-flow which fills the sump to the start level again.	Check that: <ul style="list-style-type: none"> • The distance between the start and stop levels is sufficient. • The non-return valve(s) work(s) properly. • The length of the discharge pipe between the pump and the first non-return valve is sufficiently short.
The self-holding function of the contactor malfunctions.	Check: <ul style="list-style-type: none"> • The contactor connections. • The voltage in the control circuit in relation to the rated voltages on the coil. • The functioning of the stop-level regulator. • Whether the voltage drop in the line at the starting surge causes the contactor's self-holding malfunction.

If the problem persists, then contact a sales or authorized service representative.

Always state the serial number of the product, see [Product Description](#) on page 8.

7.4 The pump runs but the motor protection trips



DANGER: Crush Hazard

Moving parts can entangle or crush. Always disconnect and lock out power before servicing to prevent unexpected startup. Failure to do so could result in death or serious injury.

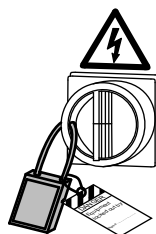

NOTICE:

Do NOT override the motor protection repeatedly if it has tripped. Doing so may result in equipment damage.

Cause	Remedy
The motor protection is set too low.	Set the motor protection according to the data plate and if applicable the cable chart.
The impeller is difficult to rotate by hand.	<ul style="list-style-type: none"> • Clean the impeller. • Clean out the sump. • Check that the impeller is properly trimmed.
The drive unit is not receiving full voltage on all three phases.	<ul style="list-style-type: none"> • Check the fuses. Replace fuses that have tripped. • If the fuses are intact, then notify a certified electrician.
The phase currents vary, or they are too high.	Contact a sales or authorized service representative.

Cause	Remedy
The insulation between the phases and ground in the stator is defective.	<ol style="list-style-type: none"> 1. Use an insulation tester. With a 1000 V DC megger, check that the insulation between the phases and between any phase and ground is > 5 megaohms. 2. If the insulation is less, then do the following: Contact a sales or authorized service representative.
The density of the pumped fluid is too high.	<p>Make sure that the maximum density is 1100 kg/m³ (9.2 lb/US gal)</p> <ul style="list-style-type: none"> • Change the impeller, or • Change to a more suitable pump • Contact a sales or authorized service representative.
The ambient temperature exceeds the maximum ambient temperature.	The pump must not be used for such an application.
The cooling system is clogged.	If the flow through the system has been partly restricted, then rinse and clean.
There is a malfunction in the overload protection.	Replace the overload protection.

If the problem persists, then contact a sales or authorized service representative.

Always state the serial number of the product, see [Product Description](#) on page 8.

7.5 The pump delivers too little or no water



DANGER: Crush Hazard

Moving parts can entangle or crush. Always disconnect and lock out power before servicing to prevent unexpected startup. Failure to do so could result in death or serious injury.

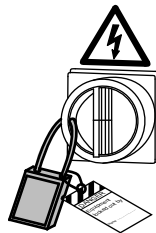

NOTICE:

Do NOT override the motor protection repeatedly if it has tripped. Doing so may result in equipment damage.

Cause	Remedy
The impeller rotates in the wrong direction.	<ul style="list-style-type: none"> • If it is a 1-phase pump, then do the following: Contact a sales or authorized service representative.
One or more of the valves are set in the wrong positions.	<ul style="list-style-type: none"> • Reset the valves that are set in the wrong position. • Replace the valves, if necessary. • Check that all valves are correctly installed according to media flow. • Check that all valves open correctly.
The impeller is difficult to rotate by hand.	<ul style="list-style-type: none"> • Clean the impeller. • Clean out the sump. • Check that the impeller is properly trimmed.
The pipes are obstructed.	To ensure a free flow, clean out the pipes.
The pipes and joints leak.	Find the leaks and seal them.

Cause	Remedy
There are signs of wear on the impeller, pump, and casing.	Replace the worn parts.
The liquid level is too low.	<ul style="list-style-type: none">• Check that the level sensor is set correctly.• Depending on the installation type, add a means for priming the pump, such as a foot valve.

If the problem persists, then contact a sales or authorized service representative.

Always state the serial number of the product, see [Product Description](#) on page 8.

8 Technical Reference

8.1 Application limits

Data	Description
Media (liquid) temperature	5–35°C (41–95°F)
pH of the pumped media (liquid)	5–8
Media (liquid) density	1100 kg/m ³ (9.2 lb per US gal) maximum
Depth of immersion	Maximum 5 m (16.5 ft)
Other	For the specific weight, current, voltage, power ratings, and speed of the pump, see the data plate of the pump. For other applications, contact a sales or authorized service representative for information.

8.2 Motor data

Feature	Description
Motor type	Squirrel-cage induction motor
Frequency	50 Hz or 60 Hz
Supply	1-phase
Maximum starts per hour	15 evenly-spaced starts per hour
Code compliance	IEC 60034-1
Voltage variation without overheating	±10%, if it does not run continuously at full load
Voltage imbalance tolerance	2%
Stator insulation class	F (155°C [311°F])

Motor encapsulation

Motor encapsulation is in accordance with IP68.

8.3 Specific motor data: Ready 8

1-phase, 50 Hz

Motor type:

- 2,770 rpm
- 750 W (1.0 hp)

Voltage (V)	Rated current (A)	Starting current (A)
115	8.7	43
230	4.2	19
240	4	20

1-phase, 60 Hz

Motor type:

- 3,270 rpm
- 820 W (1.1 hp)

Voltage (V)	Rated current (A)	Starting current (A)
115	9.8	40
230	4.8	17

8.4 Specific motor data: Ready 8S

1-phase, 50 Hz

Motor type:

- 2,800 rpm
- 900 W (1.2 hp)

Voltage (V)	Rated current (A)	Starting current (A)
115	11	43
230	5.2	19
240	5	20

1-phase, 60 Hz

Motor type:

- 3,330 rpm
- 820 W (1.1 hp)

Voltage (V)	Rated current (A)	Starting current (A)
115	9.8	40
230	4.8	17

8.5 Dimensions and weights

Ready 8

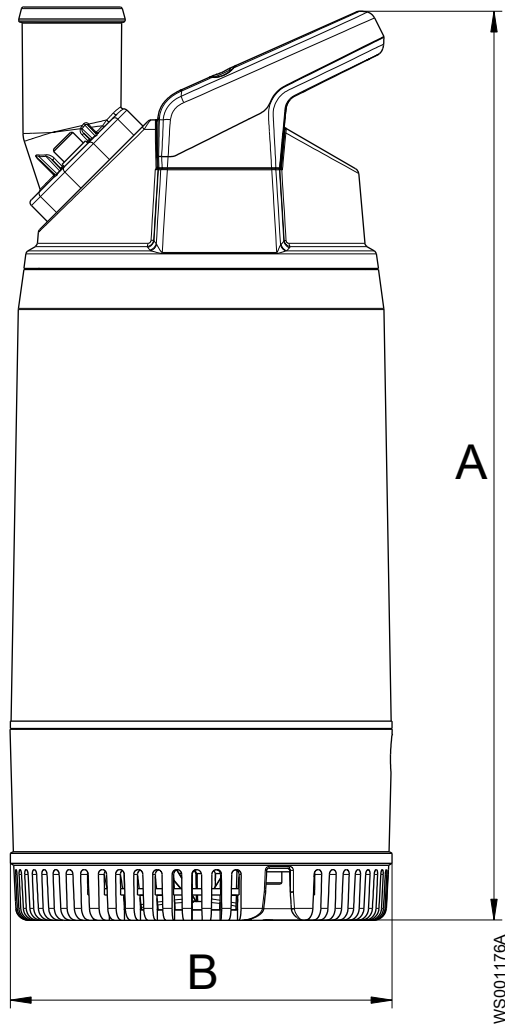

A	438 mm (17.2 in)
B	Ø184 mm (7.2 in)

Weight without motor cable: 14.5 kg (32 lb)

Ready 8S

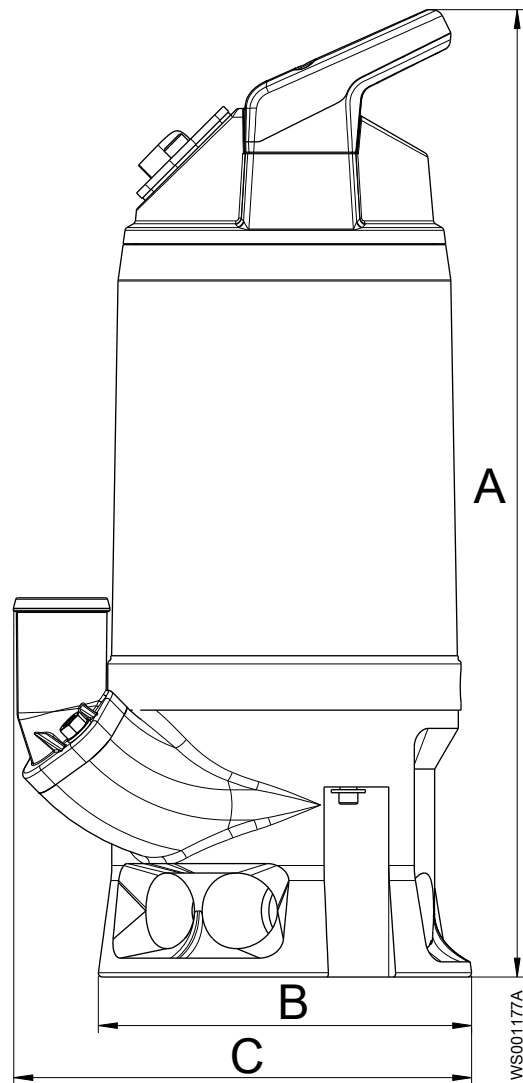

A	512 mm (20.2 in)
B	Ø197 mm (7.8 in)
C	Ø263 mm (10.4 in)

Weight without motor cable: 17 kg (37 lb)

8.6 Performance curves

Test standard

Pumps are tested in accordance with ISO 9906:2012, HI 11.6:2012.

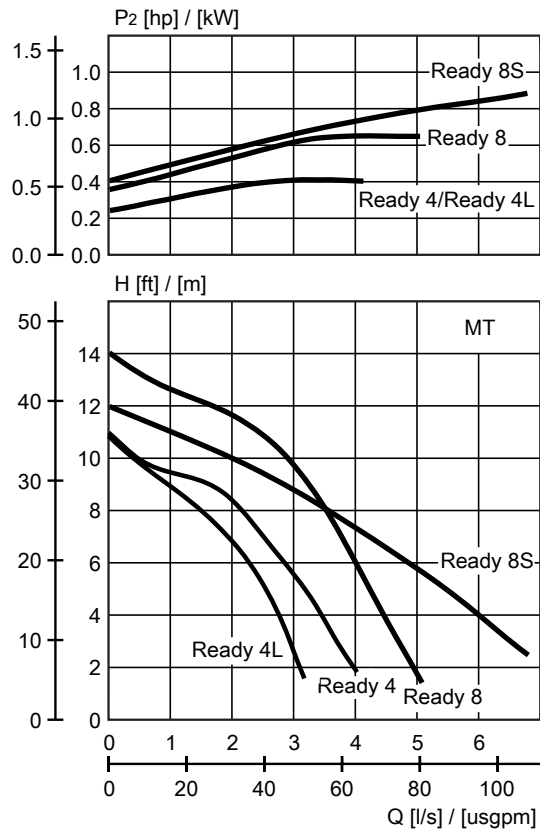

Figure 4: 50 Hz

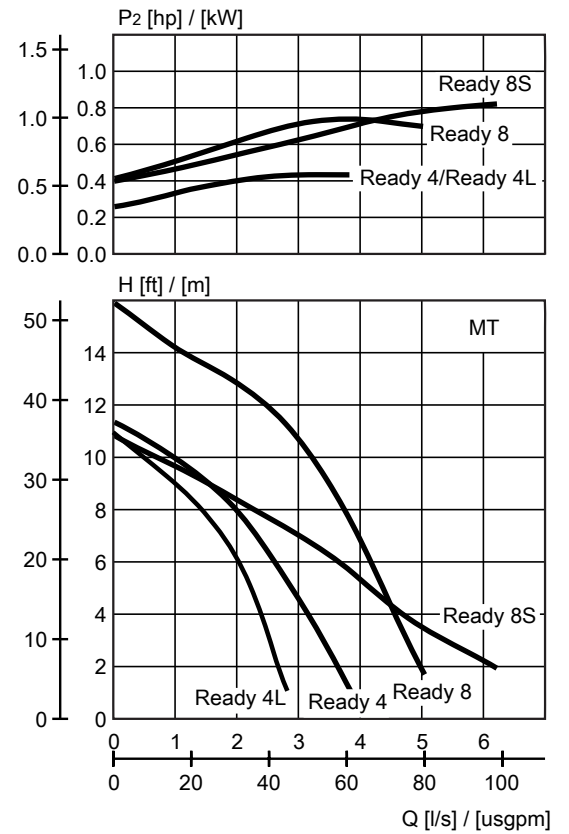

Figure 5: 60 Hz

Xylem |'zīləm|

- 1) The tissue in plants that brings water upward from the roots;
- 2) a leading global water technology company.

We're a global team unified in a common purpose: creating advanced technology solutions to the world's water challenges. Developing new technologies that will improve the way water is used, conserved, and re-used in the future is central to our work. Our products and services move, treat, analyze, monitor and return water to the environment, in public utility, industrial, residential and commercial building services, and agricultural settings. With its October 2016 acquisition of Sensus, Xylem added smart metering, network technologies and advanced data analytics for water, gas and electric utilities to its portfolio of solutions. In more than 150 countries, we have strong, long-standing relationships with customers who know us for our powerful combination of leading product brands and applications expertise with a strong focus on developing comprehensive, sustainable solutions.

For more information on how Xylem can help you, go to www.xylem.com



1300 4 BBENG
www.brownbros.com.au



0508 4 BBENG
www.brownbros.co.nz