

# Sanifos 610

## Grey water, black water

Sanifos 610 is a lifting station designed to lift rainwater and sewage from houses, commercial premises or a group of dwellings. It consists of a 610 litre tank and 1 or 2 pumps with integrated float switch(es) and the bottom of the tank is self-cleaning. It is available in 5 different single-phase or three-phase versions with a grinder pump or vortex pump. The lifting station comes with shut-off valves and non-return valve(s). The 2-pump versions come with an interactive monitoring system: the Smart control box.



### PERFORMANCE

- Max. head: 16 m
- Max. flow rate: 28 m<sup>3</sup>/h

DEPENDING ON MODEL

### PRODUCT BENEFITS

- Easy installation: pre-mounted pipework
- 4 drilling zones available for incoming water solutions
- 5 versions available: single or dual pump, single or three phase
- 2 types of pump available, either grinder or vortex
- Smart control box is available as an option



See page 10



### DELIVERED AS STANDARD (Depending on model chosen)



- Tank with pre-assembled hydraulics, 2 isolation valves and non-return valves, 3 floats installed in the tank, 1 or 2 Sanipump GR or VX, handling chain, waterproof terminal block, cable gland, smart control box (with 2 pump versions)

Sanipump VX S



Sanipump GR S



### OPTIONAL EXTRAS



Sanifos 280 extension  
Barcode: 3308815081298  
Product code: 40502



Sanifos Alarm for 1 pump versions if required  
Barcode: 3308815081625  
Product code: 40501



## DIMENSIONS

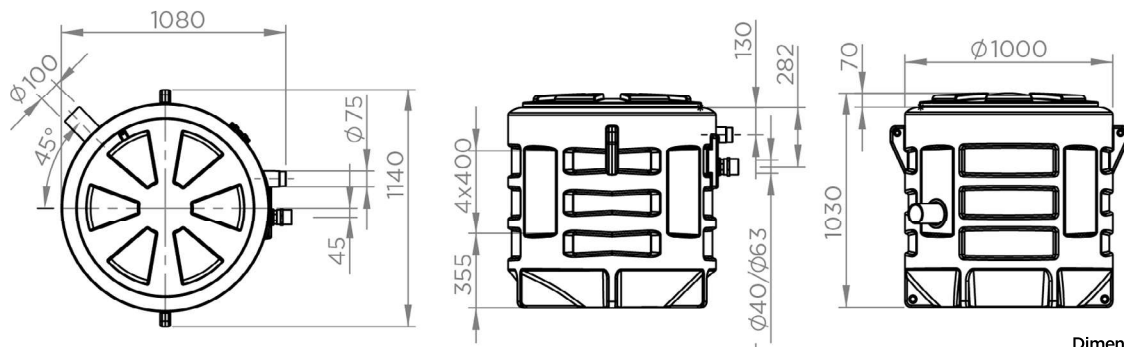

Dimensions (mm)

## CURVE

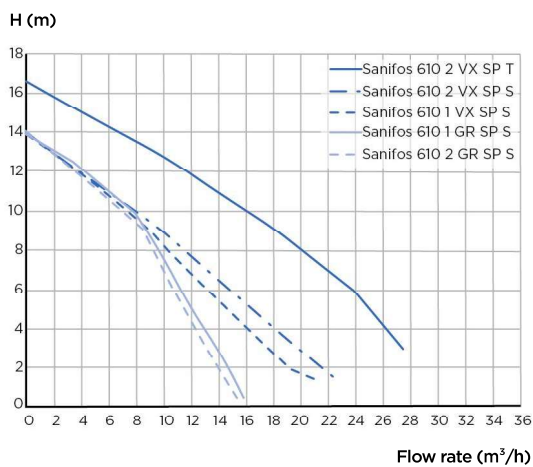

## CONNECTIONS



- External inlet diameter: 50/100 mm
- External discharge diameter: 50 mm
- ↔ External ventilation diameter: 75 mm

	Sanifos 610 1 GR SP S	Sanifos 610 1 VX SP S	Sanifos 610 2 GR SP S	Sanifos 610 2 VX SP S	Sanifos 610 2 VX SP T
Type of control box			Smart	Smart	Smart
Number of pumps	1	1	2	2	2
Material					
Tank	PE	PE	PE	PE	PE
Pipework	PVC	PVC	PVC	PVC	PVC
Electrical features					
Voltage (V)	230	230	230	230	400
Frequency (Hz)	50-60	50-60	50-60	50-60	50-60
Power consumption P1 (W)	1500	1500	1500	1500	2800
Power output P2 (W)	1050	1050	1050	1050	2240
Revolutions per minute (RPM)	2800	2800	2800	2800	2900
Electrical class	I	I	I	I	I
Motor insulation class	F	F	F	F	F
Mode of operation	S3 30%	S3 15%	S3 30%	S3 15%	-
Immersion depth (m)	5	5	5	5	5
Power cable: Length (m)	10	10	10	10	2.5
Power cable: Type of cable, section (mm <sup>2</sup> )	H07 RN-F 3G, 1.5	H07 RN-F 3G, 1.5	H07 RN-F 3G, 1.5	H07 RN-F 3G, 1.5	H07 RN-F 5G, 2.5
Hydraulics					
Max. head (m)	14.1	14	14.1	13.4	16.8
Max. flow rate (m <sup>3</sup> /h)	15.78	21	15.6	22.8	28.8
External inlet diameter (mm)	50/100	50/100	50/100	50/100	50/100
External discharge diameter (mm)	50	63	50	63	63
External ventilation diameter (mm)	75	75	75	75	75
Total volume (L)	610	610	610	610	610
Useable volume (L)	150	160	170	170	170
Alarm level (mm)			570	570	570
Min. incoming water connection (mm)	325	325	325	325	325
Max. incoming water connection (mm)	670	670	670	670	670
Type of impeller	Pro X K2 grinder	vortex	Pro X K2 grinder	vortex	vortex
Type of activation	float	float	float	float	float
Identification and logistics					
Gross weight (kg)	100	100	115	115	115
Barcode	3308815081687	3308815083094	3308815083087	3308815083100	3308815081663
Product code	40003	40004	40005	40006	40007

S = Single phase, T = Three phase.