

AQUABOOST

iBolt Pump – 03 Range

The Aquaboost iBolt pump range features a horizontal multistage pump controlled by an air-cooled variable speed frequency inverter mounted directly on the pump motor.

The iBolt pump 03 range includes 0304, 0306 and 0308 pump variants capable of delivering flow rates up to 5.0 m³/hour and capable of producing head pressures of up to 9.0 bar.



Features

- Flow rates up to 5.0 m³/h
- Head pressure up to 9.0 bar
- 304 stainless steel pump
- Dry run protection
- Stainless steel / brass discharge fittings
- Nickel plated WRAS approved ball valves
- Air cooled inverter
- BMS volt free contacts
- Hydraulic kit, base plate and anti-vibration mount options available

Application

- Cold water pressure and flow boosting in a range of domestic, commercial and industrial applications

Product Code Structure

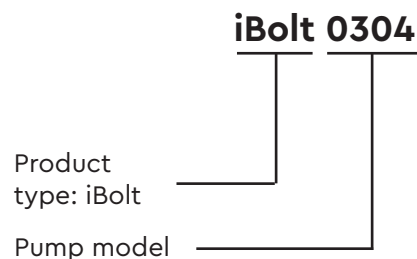

Performance Characteristics iBolt Pump - 03 Range

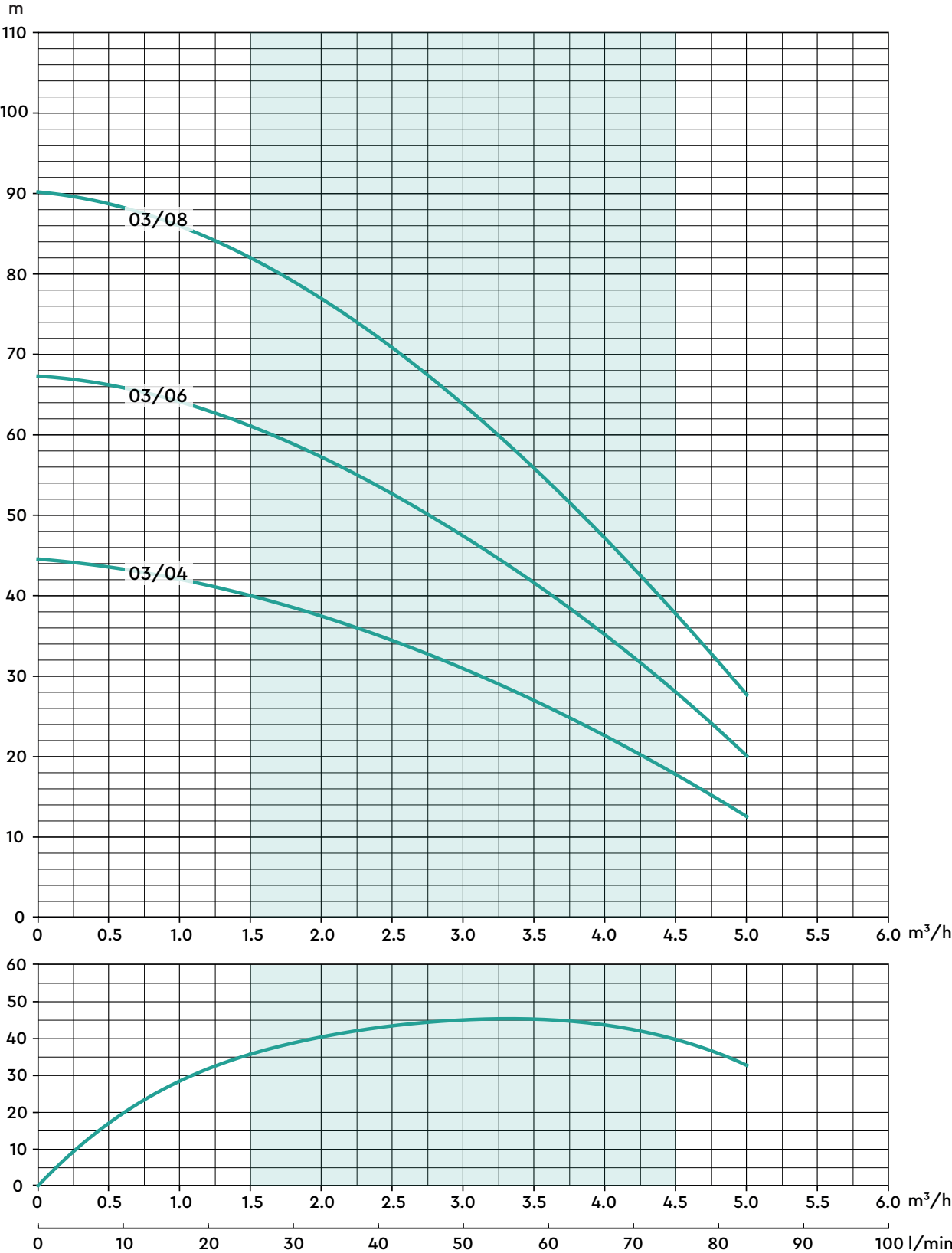

Technical Specification iBolt Pump – 03 Range

Model		iBolt Pump 0304 47345	iBolt Pump 0306 47346	iBolt Pump 0308 47378
General	Warranty	2 years		
	Conformity certification	UKCA, CE		
Features	Pump control system	Variable speed (via pressure transducer)		
	Pump control mode	Duty		
	Dry run protection	✓	✓	✓
	BMS volt-free contacts	✓	✓	✓
	Noise	<70 dB(A)		
Performance	Nominal head	3.0 bar	4.7 bar	6.4 bar
	Maximum head – closed valve	4.4 bar	6.7 bar	9.0 bar
	Nominal flow rate	3.0 m ³ /h		
	Maximum flow rate	5.0 m ³ /h		
	Minimum static inlet pressure	0.1 bar		
	Maximum static inlet pressure	1 bar		
	Maximum static outlet pressure	1.3 bar		
	Maximum ambient air temperature	40 °C		
Connections	Inlet	1 ¼"		
	Outlet	1"		
Pump	Pump type	Centrifugal multistage		
	Pump body	Stainless steel		
	Impeller	Stainless steel		
	Mechanical seal	EPDM / Carbon / Ceramic		
	Motor type	Induction (current overload sensor)		
	Duty rating	Continuous		
Electrical	Power supply / phase / frequency	230 V a.c./1/50 Hz		
	Current – full load	2.9 Amps	3.8 Amps	5.3 Amps
Physical	Enclosure protection	IP55		
	Width	176.5 mm		
	Depth	387 mm	435 mm	520 mm
	Height	300 mm	300 mm	315 mm
	Weight	13 Kg	15 Kg	19 Kg

Dimensions iBolt Pump - 03 Range

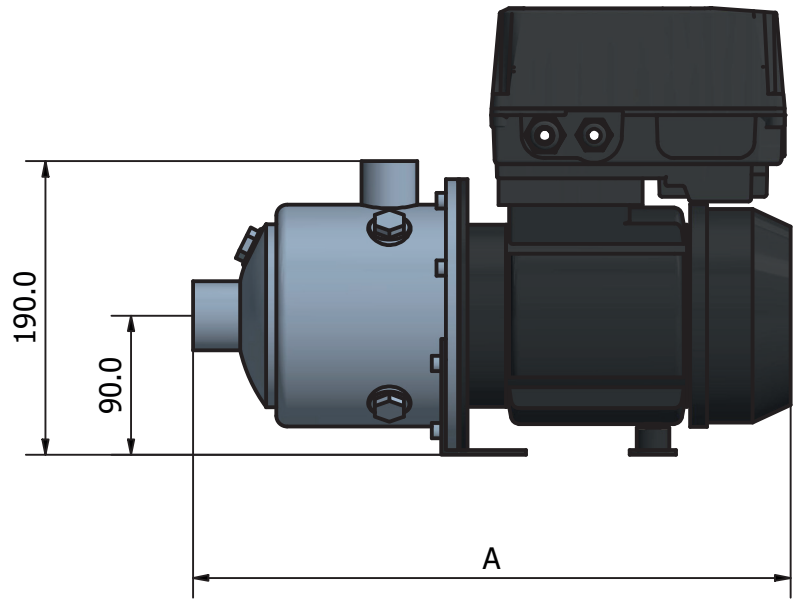
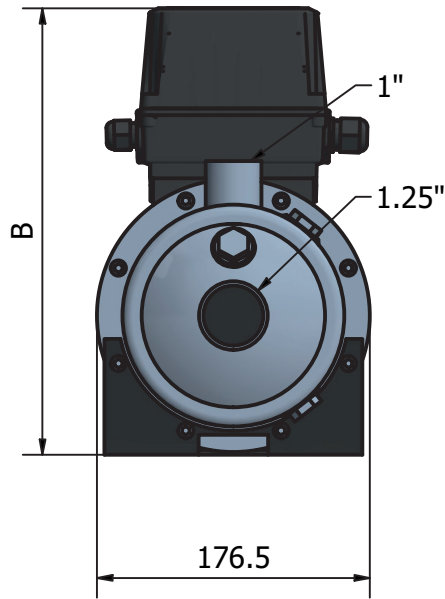

Dimension Table		
Pump Type	A (mm)	B (mm)
0304	387	300
0306	435	300
0308	520	315

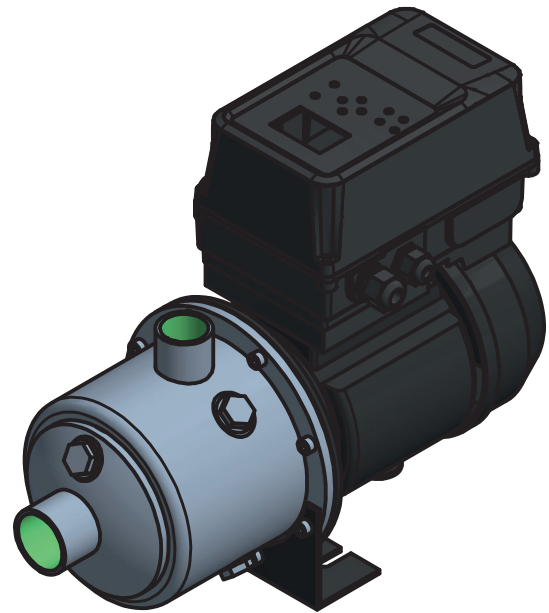

Scan QR Code for:

- Quick install information
- Operation & Maintenance manuals
- Wiring diagram
- Troubleshooting guides



Stuart Turner Limited reserves the right to amend specifications without notice.

Stuart Turner Ltd, Market Place, Henley-on-Thames, Oxfordshire, RG9 2AD

Tel: +44 (0) 1491 572655

www.stuart-turner.co.uk

Pt. No. 21139 Issue 0422-01-02