

AC-3P-MD



MAGNETICALLY DRIVEN, SINGLE-STAGE CENTRIFUGAL



PLEASE NOTE THAT PUMP MAY DIFFER FROM PRODUCT SHOWN

- ☑ Seal-less Magnetic drive pump
- ☑ Up to 33l/min flow
- ☑ Up to 4.5m head
- ☑ Available in 115V or 230V
- ☑ Extensively used in chemical recirculation, marine air conditioning, chemical transfer, scrubber systems, and many more

PERFORMANCE

SPECIFICATION

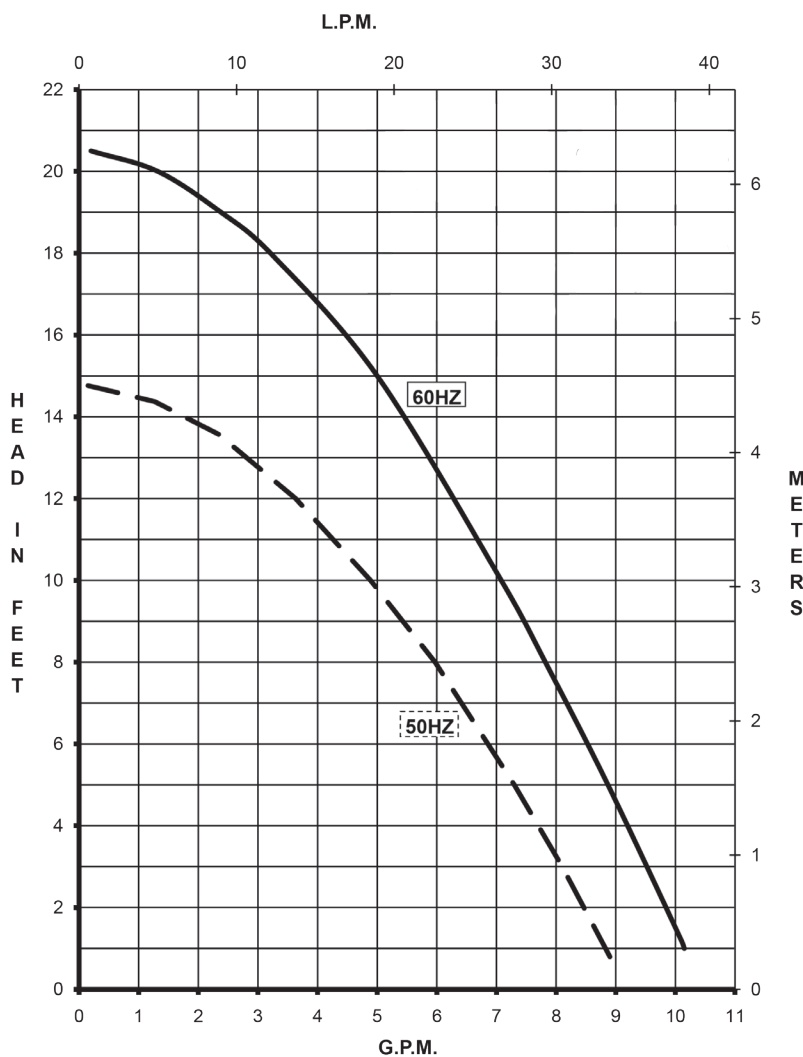

FEATURES

Temp:	Max 87°C
Pressure:	3.4 Bar (System)
Inlet:	3/4" FPT
Outlet:	1/2" MPT

WETTED MATERIALS

Front Cover:	PP
O Ring:	Viton
Shaft:	Ceramic
Thrust Washer:	Ceramic
Magnet:	Ceramic Magnet
Rear Housing:	PP



March May Ltd, Howard Road, Eaton Socon, St. Neots, Cambridgeshire, PE19 8NZ, UK

Tel: +44 (0) 1480 214444 Fax: +44 (0) 1480 405336 E-mail: sales@marchmay.co.uk Website: www.marchmay.co.uk

AC-3P-MD



MAGNETICALLY DRIVEN, SINGLE-STAGE CENTRIFUGAL

DIMENSIONS

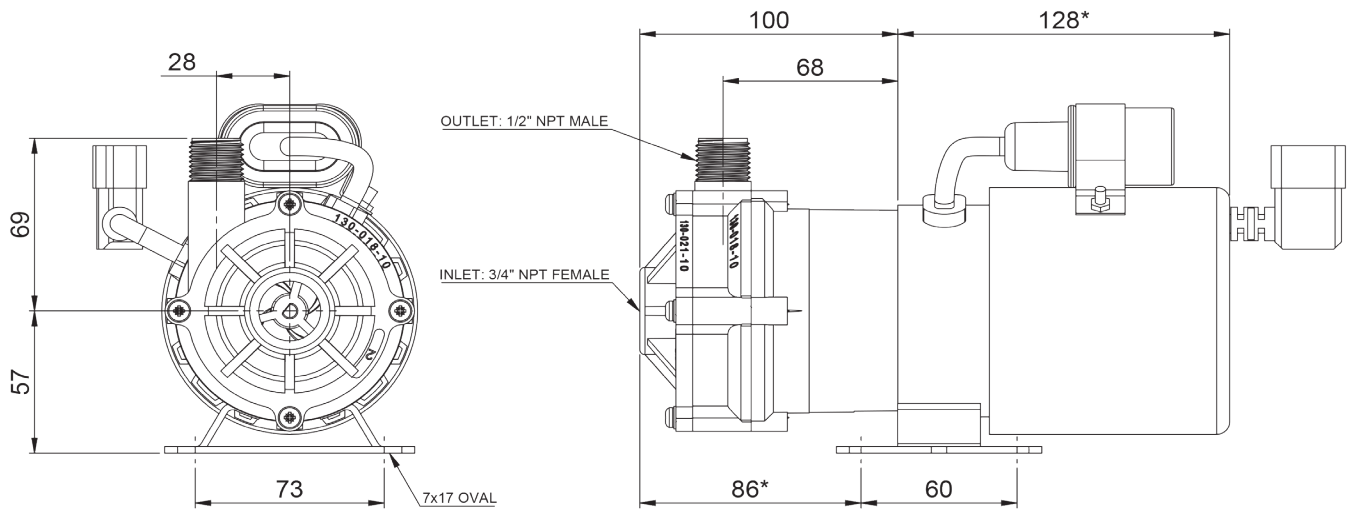

ALL DIMENSIONS GIVEN ARE IN MM

PARTS LIST

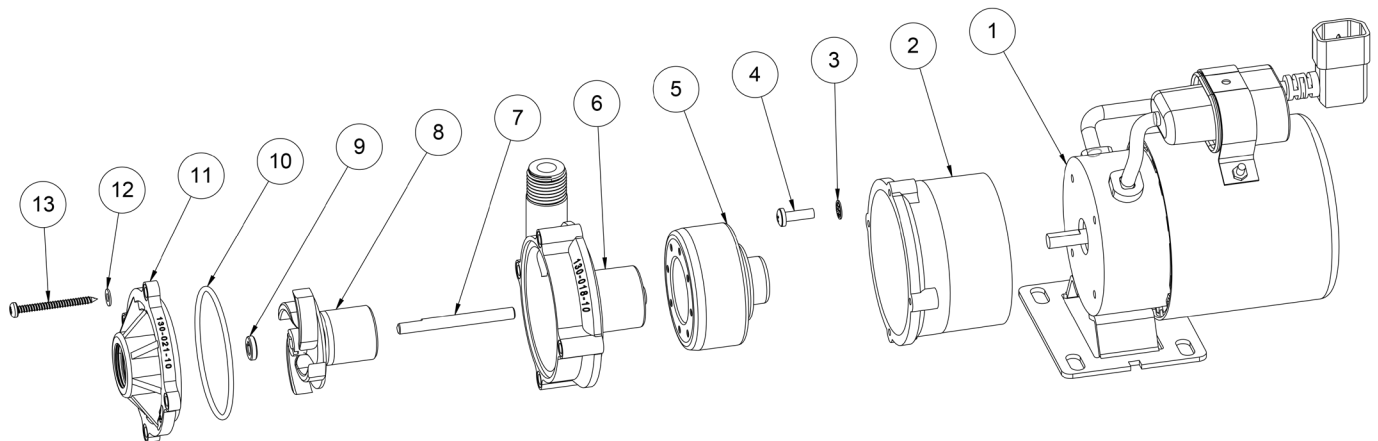

REF	DESCRIPTION	CODE	REF	DESCRIPTION	MATERIAL
1	Motor	UE96-915-00C	8	Impeller Encapsulated	0130-020-01
2	Motor Bracket	0001-030-UK	9	Thrust Washer	0130-028-UK
3	Bracket Fixing Washers	0135-200-UK	10	O Ring	0130-033-UK
4	Bracket Fixing Screws	0130-100-UK	11	Front Cover	0130-021-10
5	Drive Magnet	0130-043-02	12	Housing Washer St/St	0150-200-UK
6	Pump Housing	0130-018-10	13	Housing Screw St/St	0150-100-UK
7	Spindle	0130-024-UK			



March May Ltd, Howard Road, Eaton Socon, St. Neots, Cambridgeshire, PE19 8NZ, UK

Tel: +44 (0) 1480 214444 Fax: +44 (0) 1480 405336 E-mail: sales@marchmay.co.uk Website: www.marchmay.co.uk