

# SCALA1

Installation and operating instructions



## English (GB) Installation and operating instructions

## Original installation and operating instructions

## Table of contents

<b>1. General information</b> . . . . .	<b>5</b>
1.1 Hazard statements . . . . .	5
1.2 Notes . . . . .	5
1.3 Target group . . . . .	6
<b>2. Product introduction</b> . . . . .	<b>6</b>
2.1 Product description of SCALA 1 . . . . .	6
2.2 Intended use . . . . .	6
2.3 Pumped liquids . . . . .	6
2.4 Identification . . . . .	6
<b>3. Receiving the product</b> . . . . .	<b>7</b>
3.1 Inspecting the product . . . . .	7
3.2 Scope of delivery . . . . .	7
<b>4. Installation requirements</b> . . . . .	<b>7</b>
4.1 Location . . . . .	7
4.2 Maximum system pressure . . . . .	7
<b>5. Mechanical installation</b> . . . . .	<b>7</b>
5.1 Positioning and mounting the product . . . . .	7
5.2 Connecting the pipe system . . . . .	8
5.3 Installation examples . . . . .	10
<b>6. Electrical connection</b> . . . . .	<b>12</b>
6.1 Connecting products with a plug . . . . .	12
6.2 Connecting products without a plug . . . . .	12
6.3 Motor protection . . . . .	12
<b>7. Starting up the product</b> . . . . .	<b>12</b>
7.1 Priming the product . . . . .	12
7.2 Starting up the pump . . . . .	12
7.3 Operation . . . . .	13
7.4 Shaft seal run-in . . . . .	13
<b>8. Control functions</b> . . . . .	<b>13</b>
8.1 Operating panel . . . . .	13
8.2 Auto reset . . . . .	14
8.3 Dry-running protection . . . . .	14
8.4 Anti-cycling . . . . .	14
8.5 Maximum runtime . . . . .	14
<b>9. Setting the product</b> . . . . .	<b>14</b>
9.1 Initial setup with Grundfos Go Remote . . . . .	14
9.2 Expert settings . . . . .	14
9.3 Resetting to factory settings . . . . .	17
<b>10. SCALA1 twin booster configuration</b> . . . . .	<b>17</b>
10.1 Operation modes and parameters . . . . .	17
10.2 Setting SCALA1 twin booster system . . . . .	18
<b>11. Service</b> . . . . .	<b>19</b>
11.1 Maintenance . . . . .	19
11.2 Customer service information . . . . .	19
11.3 Service kits . . . . .	19
<b>12. Starting up after standstill</b> . . . . .	<b>19</b>
12.1 Deblocking the pump . . . . .	20
12.2 Taking the product out of operation . . . . .	20
<b>14. Storage</b> . . . . .	<b>20</b>
<b>15. Fault finding</b> . . . . .	<b>21</b>
15.1 Grundfos Eye SCALA1 . . . . .	21
15.2 The pump does not start . . . . .	22
15.3 The pump is not running . . . . .	22
15.4 The pump is running . . . . .	23
15.5 The pump cuts out during operation . . . . .	23
15.6 The pump performance is insufficient . . . . .	23
15.7 The pump starts and stops too frequently . . . . .	24
15.8 The pump does not stop . . . . .	24
15.9 The pump gives electric shocks . . . . .	24
15.10 Twin booster system fault finding . . . . .	24
15.11 Fault resetting . . . . .	24
<b>16. Technical data</b> . . . . .	<b>26</b>
16.1 Operating conditions . . . . .	26
16.2 Mechanical data . . . . .	26
16.3 Electrical data . . . . .	27
16.4 Dimensions and weights . . . . .	27
16.5 Air handling mode performance curves . . . . .	28
<b>17. Approvals</b> . . . . .	<b>29</b>
17.1 Bluetooth technology information . . . . .	29
17.2 FCC/ISED general requirements . . . . .	29
<b>18. Disposing of the product</b> . . . . .	<b>30</b>
18.1 Disposing of hazardous or toxic materials . . . . .	30

## 1. General information

This appliance can be used by children aged from 8 years and above and persons with reduced physical, sensory or mental capabilities or lack of experience and knowledge if they have been given supervision or instruction concerning use of the appliance in a safe way and understand the hazards involved.

Children shall not play with the appliance. Cleaning and user maintenance shall not be made by children without supervision.



Read this document before you install the product. Installation and operation must comply with local regulations and accepted codes of good practice.

## 1.1 Hazard statements

The symbols and hazard statements below may appear in Grundfos installation and operating instructions, safety instructions and service instructions.

**DANGER**

Indicates a hazardous situation which, if not avoided, will result in death or serious personal injury.

**WARNING**

Indicates a hazardous situation which, if not avoided, could result in death or serious personal injury.

**CAUTION**

Indicates a hazardous situation which, if not avoided, could result in minor or moderate personal injury.

The hazard statements are structured in the following way:

**SIGNAL WORD****Description of the hazard**

Consequence of ignoring the warning

- Action to avoid the hazard.

## 1.2 Notes

The symbols and notes below may appear in Grundfos installation and operating instructions, safety instructions and service instructions.



Observe these instructions for explosion-proof products.



A blue or grey circle with a white graphical symbol indicates that an action must be taken.



A red or grey circle with a diagonal bar, possibly with a black graphical symbol, indicates that an action must not be taken or must be stopped.



If these instructions are not observed, it may result in malfunction or damage to the equipment.



Tips and advice that make the work easier.

### 1.3 Target group

These installation and operating instructions are intended for professional as well as non-professional users.

## 2. Product introduction

### 2.1 Product description of SCALA 1

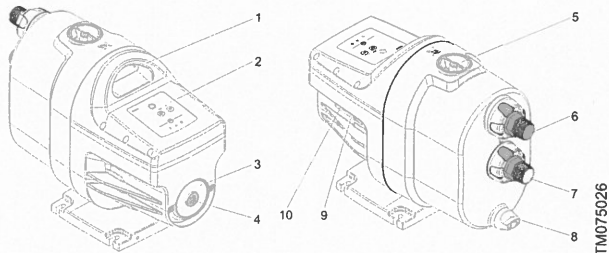

Pos.	Description
1	Lifting handle
2	Operating panel
3	Nameplate
4	Plug for access to pump shaft
5	Priming plug
6	Outlet connection
7	Inlet connection
8	Drain plug
9	External input connection
10	Twin connection

### 2.2 Intended use



Only use the product according to the specifications stated in these installation and operating instructions.

The product is suitable for pressure boosting of clean water in domestic water-supply systems.

### 2.3 Pumped liquids

#### DANGER Explosion risk

Death or serious personal injury

- Do not use the product for flammable liquids such as diesel oil, petrol or similar liquids. The product must only be used for water.

#### WARNING

#### Electric shock

Death or serious personal injury

- Do not use the product for aggressive liquids. The product must only be used for water.

#### WARNING

#### Toxic material

Death or serious personal injury

- Do not use the product for toxic liquids. The product must only be used for water.



If the water contains sand, gravel or other debris, there is a risk of pump blockage and pump damage. Install a filter on the inlet side or apply a floating strainer to protect the pump.

The product is suitable for pumping clean, thin, non-aggressive and non-explosive liquids without solid particles or fibres.

The product is designed for fresh water with a maximum chloride content of 300 ppm and a free chlorine content below 1 ppm.

Examples of liquids:

- drinking water
- rainwater.

### 2.4 Identification

#### 2.4.1 Nameplate for SCALA1

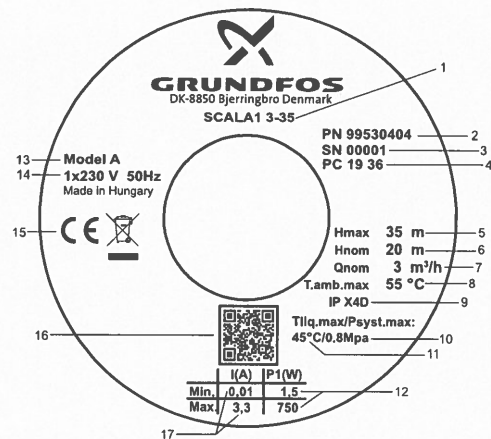

Example of nameplate

Pos.	Description
1	Type designation
2	Product number
3	Serial number
4	Production code (year and week)
5	Max. head
6	Nominal head
7	Nominal flow rate
8	Max. ambient temperature
9	Enclosure class
10	Max. operating pressure
11	Max. liquid temperature
12	Minimum and maximum rated power
13	Model
14	Voltage and frequency
15	Approvals
16	Product QR code
17	Minimum and maximum rated current

TM075340

## 2.4.2 Type key for SCALA1

Example:

SCALA1 . 5- . 25 . 1x230V . 50 Hz . SCHUKO

	Description
SCALA1	Type range
3	Max. flow rate [m <sup>3</sup> /h]
5	
25	Max. head [m]
35	
45	
55	
1x230V	
1x115V	
50 Hz	Frequency [Hz]
60 Hz	
SCHUKO (Type E/F)	Plug type
No plug	
Thailand (Type O)	
Australia (Type I)	
UK (Type G)	
US (Type NEMA 5-15, NEMA 6-15)	
Argentina (Type I)	

## 3. Receiving the product

### 3.1 Inspecting the product

On receipt of the product, do the following:

1. Check that the product is as ordered.  
If the product is not as ordered, contact the supplier.
2. Make sure that the supply voltage and frequency correspond to the values stated on the product nameplate.

### 3.2 Scope of delivery

The box contains the following items:

- 1 Grundfos SCALA1 pump
- 1 quick guide
- 1 safety instructions booklet.

## 4. Installation requirements

### 4.1 Location

The product can be installed both indoors and outdoors.

Please observe the following:

- Install the product to enable easy inspection, maintenance, and service.
- We recommend that you place the product as close as possible to the liquid to be pumped.
- We recommend that you install the product near a drain or in a drip tray connected to a drain in order to lead away possible condensation from cold surfaces.

#### 4.1.1 Installation of the product in a frosty environment

Be aware of the risk of frost in the environment where the pump is installed, especially in areas where frost may occur.

#### 4.1.2 Minimum space

The pump requires a minimum space of 495 x 225 x 340 mm (19.5 x 8.9 x 13.4 inches).

Even though the pump does not require much space, we recommend that you leave enough space for service and maintenance access.

### 4.2 Maximum system pressure



Make sure that the system in which the pump is installed is designed for the maximum pump pressure

The maximum inlet pressure depends on the head at the actual duty point. The sum of the inlet pressure and the head must not exceed the maximum system pressure.

We recommend installing a pressure-relief valve to protect the pump so that the outlet pressure does not exceed the maximum system pressure.

## 5. Mechanical installation

### WARNING

#### Electric shock

Death or serious personal injury



- Switch off the power supply before you start any work on the product. Make sure that the power supply cannot be switched on accidentally.

### WARNING

#### Electric shock

Death or serious personal injury



- Mount the product horizontally to avoid condensation in the electrical insulation inside the control box.

### WARNING

#### Chemical hazard

Death or serious personal injury



- Before the pump is used for supplying drinking water, flush the pump thoroughly with clean water.

### WARNING

#### Biological hazard

Death or serious personal injury



- Before the pump is used for supplying drinking water, flush the pump thoroughly with clean water.

### 5.1 Positioning and mounting the product



Always place the product in a horizontal position. A higher inclination can cause electric shock due to condensation in the electrical insulation inside the control box.

1. Place the product in a horizontal position with a maximum inclination angle of  $\pm 5^\circ$ . The base plate must face downwards.
2. Fasten the product to a solid horizontal foundation by means of screws through the holes in the base plate.

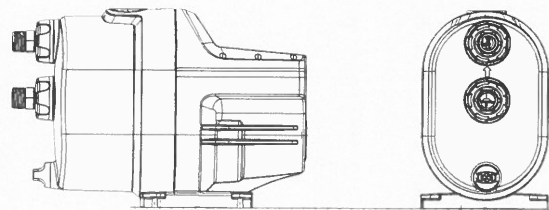

Horizontal foundation

TM075005

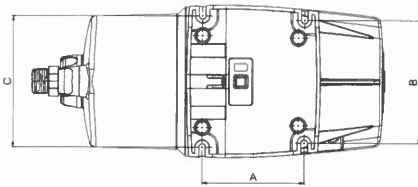

TM075004

Base plate

	[mm (in)]
A	135 (5.3)
B	163 (6.4)
C	174 (6.9)

**5.2 Connecting the pipe system**

- ! Make sure that the pump is not stressed by the pipe system.
- ! Always loosen and tighten the union nuts on the inlet and outlet ports by hand. Damage to the inlet and outlet parts increases the risk of leakage.
- 💡 We recommend that you install isolating valves on the inlet and outlet side of the pump.

1. Turn the union nuts by hand to loosen the inlet and outlet ports.
2. Seal the pipe fittings with thread sealing tape.
3. Carefully screw the inlet and outlet connections onto pipe fittings using a pipe wrench or a similar tool. Keep the union nut on the pipe fitting if you have removed it from the pump. The pump is equipped with flexible connections,  $\pm 5^\circ$ , to facilitate the connection of inlet and outlet pipes.
4. Fasten the connections to the inlet and outlet ports by holding the connection with one hand and tightening the union nut with the other hand.

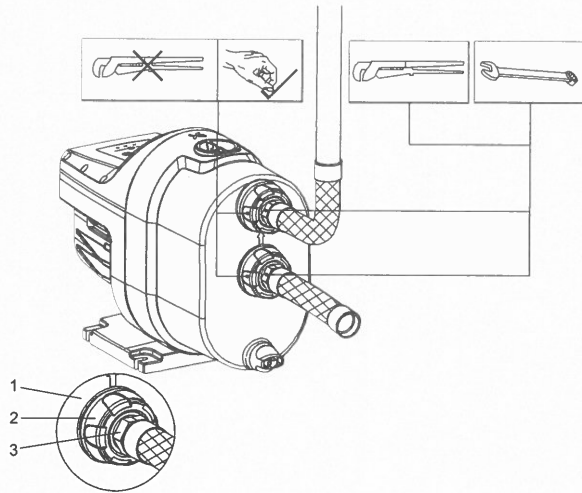

TM075341

*Inlet pipe with a gradual upward slope towards the pump*

**Example:**

Pos.	Description
1	Inlet and outlet port
2	Union nut
3	Pipe fitting

**5.2.1 Inlet and outlet pipes**

Follow these general precautions when connecting the inlet and outlet pipes.

- ! Do not let the pump support the pipes. Use pipe hangers or other supports at proper intervals to provide pipe support near the pump.
- ! The internal diameter of the pipes must never be smaller than the diameter of the pump ports.
- Install the pipes so that air pockets are avoided, especially on the inlet side of the pump.
- Use eccentric reducers with the tapered side down.
- Make sure the pipes are as straight as possible to avoid unnecessary bends and fittings. We recommend long-radius 90° pipe bends to decrease friction loss.
- Run the inlet pipe as direct as possible and, ideally, make sure that the length is at least ten times the pipe diameter.
- If possible, run a horizontal inlet line. We recommend a gradual upward slope for pumps operating in suction-lift conditions.
- A short pipe must be of the same diameter as the inlet port or larger.
- A long pipe must be one or two sizes larger than the inlet port, depending on the length.

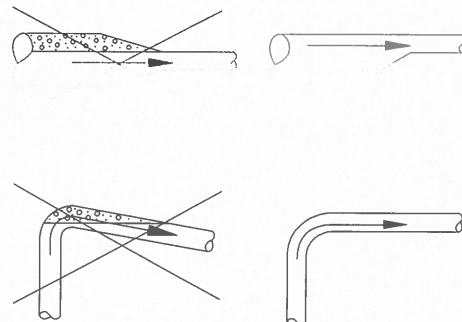

TM040338

*Recommended pipe installation to avoid friction and air pockets*

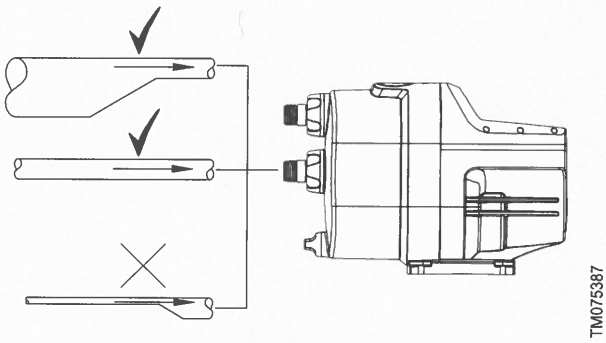

TM075387

Correct pipe sizing for connection to the pump inlet or outlet

### 5.2.2 Maximum tapping point

We recommend that you install the unit so that the height between the unit and the highest tapping point does not exceed the values shown in the table below.

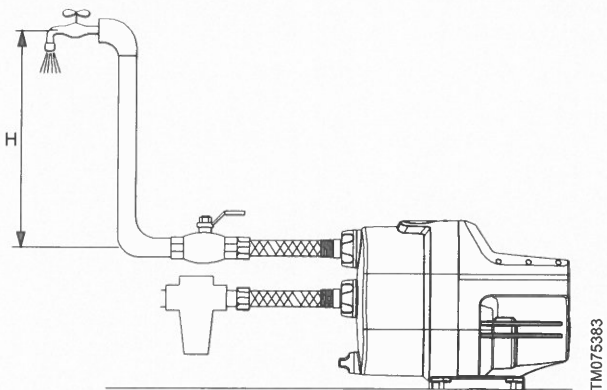

TM075383

Maximum tapping point

Model	Maximum height [m]
3-25	10
3-35	15
3-45	20
5-25	10
5-55	25

In case the highest tapping point is higher than the values in this table, the external input may be used.

### 5.3 Installation examples

We recommend that you follow the installation examples. Valves are not supplied with the pump.

#### 5.3.1 Suction from a well

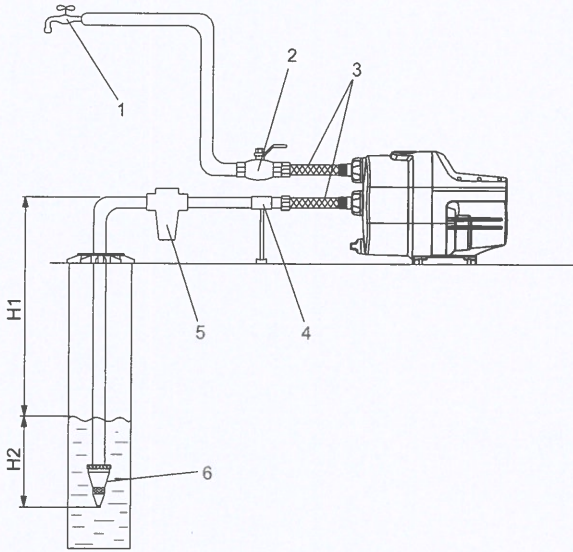

TM075006

Pos.	Description
1	Highest tapping point
2	Isolating valve
3	Flexible hoses
4	Pipe support
5	Inlet filter
6	Foot valve with strainer
H1	Maximum suction lift: 8 m
H2	Inlet pipe must be submerged at least 0.5 m

#### 5.3.2 Suction from a tank

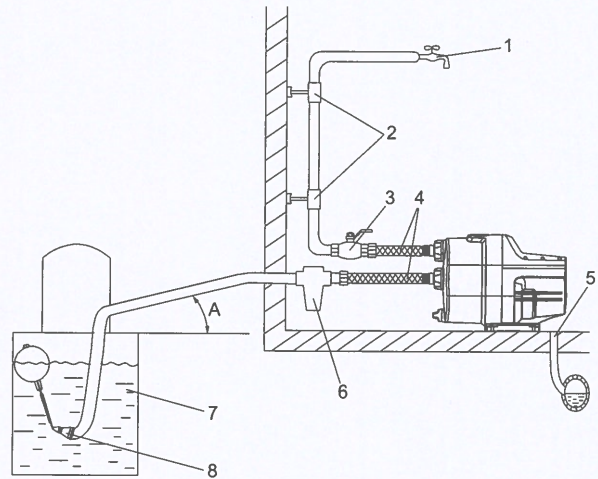

TM075007

Pos.	Description
1	Highest tapping point
2	Pipe hangers
3	Isolating valve
4	Flexible hoses
5	Drain to sewer
6	Inlet filter
7	Freshwater tank
8	Foot valve with strainer
9	Minimum 1-degree inclination

### 5.3.3 Mains water pressure boosting

**!** In some countries, boosting from the city water mains is prohibited. Please follow local regulations regarding this application.

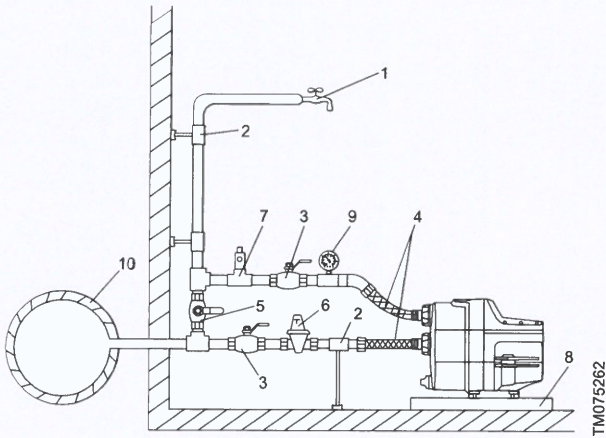

Pos.	Description
1	Highest tapping point
2	Pipe hangers and supports
3	Isolating valves
4	Flexible hoses
5	Bypass valve
6	Optional pressure-reducing valve on the inlet side if the pressure can exceed 8 bar (115 psi).
7	Optional pressure relief valve on the outlet side if the installation cannot withstand the outlet pressure.
8	Drip tray. Install the pump on a small stand to prevent the ventilation holes from being flooded.
9	Pressure gauge
10	Mains water pipe

### 5.3.4 Inlet pipe length

The overview below shows the different possible inlet pipe lengths, depending on the vertical pipe length. The overview is only intended as a guide.

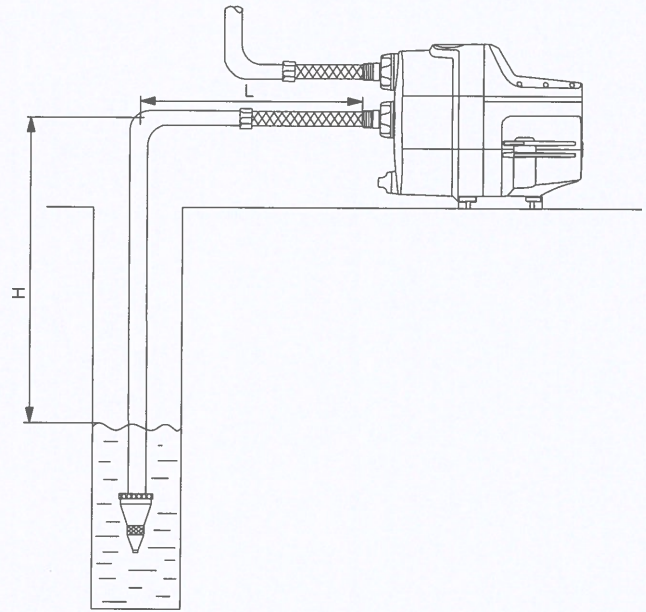

Inlet pipe length

DN 32		DN 40	
H	L	H	L
[m (ft)]	[m (ft)]	[m (ft)]	[m (ft)]
0 (0)	68 (223)	0 (0)	207 (679)
3 (10)	43 (141)	3 (10)	129 (423)
6 (20)	17 (56)	6 (20)	52 (171)
7 (23)	9 (30)	7 (23)	26 (85)
8 (26)	0 (0)	8 (26)	0 (0)

**Pre-conditions:**

Maximum flow velocity: 1 l/s (16 gpm).

Inside roughness of pipes: 0.01 mm (0.0004 in).

Size	Inside pipe diameter [mm (in)]	Pressure loss [mm (psi/ft)]
DN 32	28 (1.1)	0.117 (5/100)
DN 40	35.2 (1.4)	0.0387 (1.6/100)



## 6. Electrical connection

### WARNING

#### Electric shock

Death or serious personal injury



- Switch off the power supply before you start any work on the product. Make sure that the power supply cannot be switched on accidentally.

### WARNING

#### Electric shock

Death or serious personal injury



- The protective earth (PE) of the power outlet must be connected to the protective earth of the pump. The plug must have the same PE connection system as the power outlet.



All electrical connections must be carried out by qualified persons in accordance with local regulations.



If the power cable is damaged, it must be replaced by the manufacturer, the manufacturer's service partner or a similarly qualified person.



Make sure that the electrical installation supports the rated current [A] of the product. See the nameplate of this product.

### 6.1 Connecting products with a plug

#### WARNING

#### Electric shock

Death or serious personal injury



- Make sure that the power plug delivered with the product is in compliance with local regulations.
- The plug must have the same protective earth (PE) connection system as the power outlet. If not, use a suitable adapter if allowed by local regulations.



Do not turn on the power supply until the pump has been filled with liquid.

1. Switch off the power supply to the power socket.
2. Connect the plug to the power socket.

### 6.2 Connecting products without a plug

#### WARNING

#### Electric shock

Death or serious personal injury



- Power cables without a plug must be connected to a supply disconnecting device incorporated in the fixed wiring according to the local wiring rules.
- The protective earth (PE) of the power outlet must be connected to the protective earth of the pump. The plug must have the same PE connection system as the power outlet.



Do not turn on the power supply until the pump has been filled with liquid.

If the product is delivered with a cable but without a plug, connect the cable to the external main switch or attach a plug.

#### Connecting the cable to an external main switch

1. Strip the cable.
2. Thread each individual wire to the correct terminal in the external main switch.

#### Wiring a plug

1. Strip the cable.

2. Loosen the two screws holding the cable clamp and pull the cable through.
3. Thread each individual wire to the correct terminal.
4. Tighten the terminal screws and the cable clamp screw. Make sure not to overtighten the cable clamp screw.

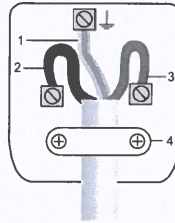

Example, plug wiring

Pos.	Description
1	PE: Earth, yellow and green wire
2	N: Neutral, blue wire
3	L: Live, brown wire
4	Cable clamp

### 6.3 Motor protection

The pump incorporates current- and temperature-dependent motor protection. If the pump is blocked or otherwise overloaded, the built-in thermal switch will cut out. When the motor has cooled sufficiently, it will restart automatically.

No external motor protection is required.

## 7. Starting up the product



Do not turn on the power supply until the pump has been filled with liquid.

### 7.1 Priming the product

1. Unscrew the priming plug and pour at least 1.7 litres (0.45 gallons) of water into the pump housing.
2. Screw the priming plug on again.

#### Example:

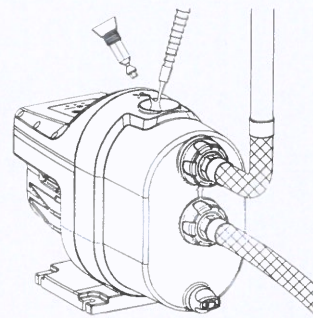

Priming the pump



If the suction depth exceeds 6 m (20 ft), it may be necessary to prime the pump more than once.



Always tighten priming and drain plugs by hand.

### 7.2 Starting up the pump

After installing and priming, follow the following steps to start up the pump.

1. Prime the pump according to the priming instructions.

TM072505

TM075342

- Open all isolating valves.
- Open the tapping point that is the highest or furthest away from the pump to let out air trapped in the system.
- Turn on the pump's power supply. All the symbols on the operating panel will light up briefly. The **Stop** icon remains on.
- Press the **Start/Stop** button to start the pump. If there is a suction lift, it may take up to five minutes before the pump delivers water depending on the length and diameter of the inlet pipe.
- When the water flows through the tapping point without air, close the tapping point. The pump will stop after approx. 10 seconds.
- The startup is now completed, and the pump is ready for operation.

### 7.3 Operation

#### 7.3.1 Normal operation

When water is consumed in the water supply system, the pump starts if the starting conditions of the pump are fulfilled. This happens, for example, when a tap is opened, making the pressure in the system drop.

The pump stops when the consumption stops, i.e. when the tap is closed.

#### 7.3.1.1 Starting and stopping conditions

##### Starting conditions

The pump starts when at least one of the following conditions is fulfilled:

- The flow is higher than  $Q_{min}$  (1.5 l/min).
- The pressure is lower than  $p_{start}$ .

##### Stopping conditions

The pump stops with a time delay of 10 seconds when both of the following conditions are fulfilled:

- The flow is lower than  $Q_{min}$  (1.5 l/min).
- The pressure is higher than  $p_{start}$ .

The  $p_{start}$  values are shown in Technical data.

#### 7.4 Shaft seal run-in

The shaft seal faces are lubricated by the pumped liquid. A slight leakage from the shaft seal of up to 10 ml per day or 8 to 10 drops per hour may occur. Under normal conditions, the leaking liquid will evaporate. As a result, no leakage will be detected.

When the pump is started for the first time, or when the shaft seal has been replaced, a certain run-in period is required before the leakage is reduced to an acceptable level. The time required for this depends on the operating conditions, that is, every time the operating conditions change, a new run-in period will be started.

Leaking liquid will drain through the drain holes in the motor flange.

Install the product in such a way that leakage cannot cause undesirable collateral damage.

## 8. Control functions

### 8.1 Operating panel



TMD75407

Symbol	Description
	<b>Grundfos Eye:</b> The indicator light shows the operating status of the product.
	<b>Start/Stop:</b> Press the button to make the product ready for operation or to start and stop the product. <b>Start:</b> If you press the button when the product is stopped, the product starts if no other functions with higher priority have been enabled. <b>Stop:</b> If you press the button when the product is running, the product always stops.
	<b>Stop</b> Pump is stopped. The stop icon will light up on the display.
	Bluetooth connect button enables communication with Grundfos GO Remote. Connection indicator light. It will light up when the connection to Grundfos GO Remote is established.
	<b>Reset</b> Reset the alarms.

The following alarm lights indicate an issue with installation:

	Leakage in the system.
	Dry-running or water shortage.
	The maximum running time has been exceeded.

## 8.2 Auto reset

This function allows the pump to automatically check if the operating conditions are back to normal. If the operating conditions are back to normal, the alarm indication will be reset automatically.

The factory setting is: **ON**

The auto reset function works as follows:

Alarm	Auto reset action	Configurable	Default
Dry run	The pump will attempt eight restarts at five-minute intervals. If not successful, this cycle will be repeated after 24 hours. In twin configuration Duty/Assist, there is no reset if only one pump is in dry run alarm. If both pumps are in dry run, the reset will be staggered. In twin configuration Duty/Standby, the pump will attempt to restart immediately independent of the second pump.	YES	ON
Anti-cycling	This function will attempt to reset after 12 hours, and the pump will return to normal operation.	YES	ON
Max. runtime	None	Fixed disabled	
Missed twin pump	Auto reset is performed by the system when communication is reestablished.	Fixed enabled	

## 8.3 Dry-running protection



If a dry-running alarm has been activated, the cause should be identified before the pump is restarted to prevent damage to the pump.

The unit incorporates dry-running protection that automatically stops the pump in case of dry-running. The dry-running protection functions differently during priming and operation.

### 8.3.1 Dry-running during priming

If the unit does not detect pressure and flow within 5 minutes after it has been connected to a power supply, and the pump has started, the dry-running alarm is activated.

### 8.3.2 Dry-running during operation

If the unit does not detect pressure and flow within 40 seconds during normal operation, the dry-running alarm is activated.

### 8.3.3 Resetting of dry-running alarm

If the dry-running alarm has been activated, the pump can be restarted manually by pressing [Reset]. If the unit does not detect pressure and flow within 40 seconds after restarting, the dry-running alarm is reactivated.

This protection is always **ON**.



Dry-running or water shortage.

## 8.4 Anti-cycling

If there is a minor leakage in the system, or a tap has not been closed entirely, the unit will start and stop the pump periodically. To avoid cycling, the anti-cycling function of the unit will stop the pump and indicate an alarm. The anti-cycling function can be configured in Grundfos GO Remote.

### Off

If the pump starts 40 times in a fixed pattern, a LED icon will signalize cycling. The pump will remain in normal operation.



If the pump starts and stops in a fixed pattern, there is a leakage in the system, and the pump will stop and show red Grundfos Eye and LED icon indication.

The factory setting for this function is **OFF**.



Leakage in the system.

## 8.5 Maximum runtime

This function is a timer that can turn off the pump if it runs continuously for a certain amount of time. This time period can be adjusted via Grundfos GO Remote.

### Off

The pump will run depending on the operating conditions disregarding the continuous operation.

### On

The pump will stop after the specified period of continuous operation, and it will show the alarm **Maximum runtime exceeded**. This alarm will always need to be reset manually.

The factory setting for this function is **OFF**.



Maximum runtime exceeded.

## 9. Setting the product

### 9.1 Initial setup with Grundfos Go Remote

#### 9.1.1 Startup wizard on Grundfos GO Remote

The product is designed for Bluetooth communication with Grundfos GO Remote.

Once you have connected your product to Grundfos GO Remote, a startup wizard appears. Follow the instructions to make your settings.

Grundfos GO Remote enables you to set functions and gives you access to status overviews, technical product information and current operating parameters.

#### 9.1.2 Connecting to Grundfos GO Remote

Before connecting the product to Grundfos GO Remote, the Grundfos GO Remote app must be downloaded to your smartphone or tablet. The app is free of charge and available for iOS and Android devices.

1. Open Grundfos GO Remote on your device. Make sure that Bluetooth is enabled.  
Your device must be within reach of the product to establish Bluetooth connection.
2. Press the Bluetooth **CONNECT** button on Grundfos GO Remote.
3. Press the connect button on the operating panel. The blue LED above the connect button is flashing until your device is connected. Once the connection is established, the LED will be permanently on.  
Grundfos GO Remote is now loading the data for the product.

### 9.2 Expert settings

Grundfos GO Remote allows you to enable additional conditions for pump operation.

### 9.2.1 External input

This pump allows connecting external input as an additional condition to the pump operation.

External input may be beneficial in the following situations:

- level switch in roof tank filling to stop the pump when the tank is full
- inlet pressure switch to stop the pump in case of raised inlet pressure
- moisture detection switch in irrigation applications to run the pump only when the ground is dry.

External input must be 24 V digital input and can be connected through the opening on the pump body. The cable length is limited to 30 m.



External input can only be set up with Grundfos GO Remote.

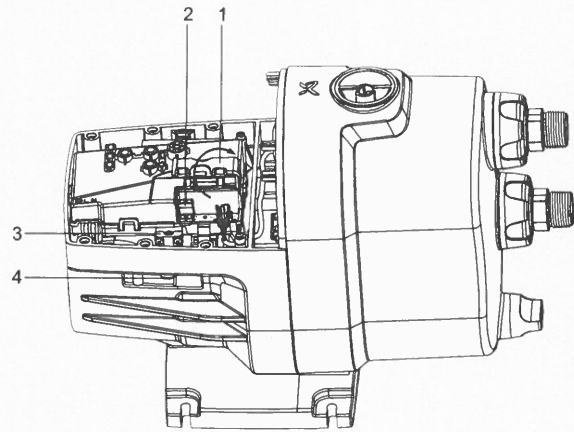

TM075384

#### 9.2.1.1 Setting up external input

##### WARNING

##### Electric shock

Death or serious personal injury



- Switch off the power supply before you start any work on the product. Make sure that the power supply cannot be switched on accidentally.

##### WARNING

##### Electric shock

Death or serious personal injury



- The protective earth (PE) of the power outlet must be connected to the protective earth of the pump. The plug must have the same PE connection system as the power outlet.



All electrical connections must be carried out by qualified persons in accordance with local regulations.



If the power cable is damaged, it must be replaced by the manufacturer, the manufacturer's service partner or a similarly qualified person.



Make sure that the electrical installation supports the rated current [A] of the product. See the nameplate of this product.

#### Connecting external input

Pos.	Description
1	Lid on PCB cover
2	Terminals
3	Cable clip
4	Cable gland

1. Remove the screws and lift the pump cover.
2. Open the lid on the PCB cover.
3. Pull the cable through the gland and the clip.
4. Connect to the terminals.
5. Fix the clip to hold cable in place.
6. Close the lid.
7. Return the pump cover and screw it in place.
8. Power on the pump and connect with Grundfos GO Remote.

### 9.2.1.2 Roof tank filling

In the installation below, the level switch is used to signal the pump to run when the water level in the tank drops.

The example below shows the float switch in the input closed position. In this case, the pump should not run, and Grundfos GO Remote settings indicate that the input is closed.

If you exceed the maximum tapping point of the pump, the external input should run on input only.

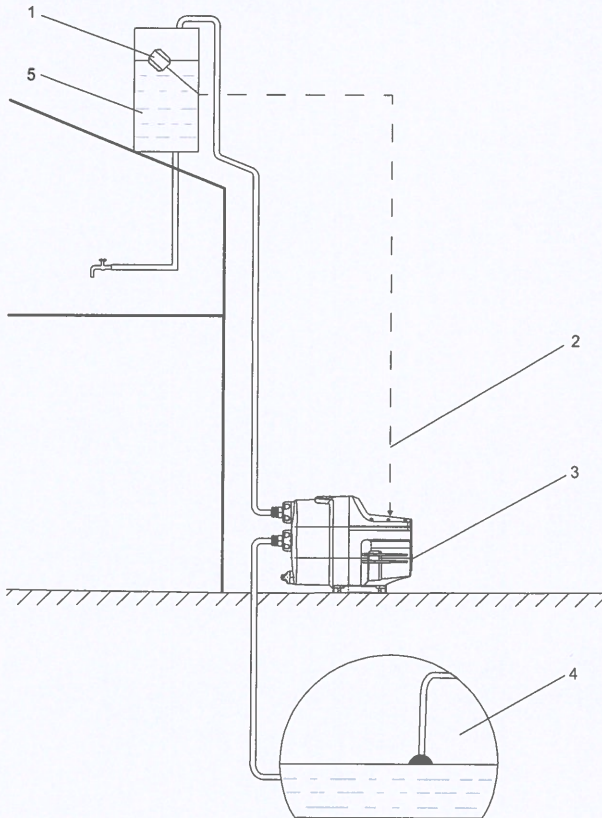

TM075330

Pos.	Description
1	Float switch
2	External input (switch) cable
3	Pump
4	Water source (tank)
5	Roof tank

### 9.2.2 Calendar function

The operation of SCALA1 can be scheduled in the calendar function of the Grundfos GO Remote app.

This function determines when the pump is allowed to run and when not. It is particularly beneficial for irrigation and agriculture purposes, where the pump should be active only within a certain

#### 9.2.2.1 Enabling calendar function

To enable this function, go to Grundfos GO Remote app and follow these steps:

1. Connect to the pump.
2. Go to **Scheduling**.
3. Press **Save schedule**.

The pump will now run on demand, but only within the time period set in the calendar function.



When the pump has been stopped by the calendar function, it will be indicated on the HMI by a steady yellow Grundfos Eye.

### 9.2.3 Performance modes

Different performance modes can be selected for SCALA1. Selecting the correct mode is dependent on the installation.

There are 3 performance modes for SCALA1:

- self-priming
- air handling
- positive inlet.

The default mode is self-priming, which will be the desired mode for most installations.

Performance mode	Description	Benefits
Self-priming	The self-priming valve is fully opened.	Best performance and lowest noise level in suction applications.
Air handling <sup>1</sup>	When there is air in the installations, it can accumulate in the hydraulics. Partially closing the self-priming valve can provide assistance.	Improves the pump's capability to handle air in the water.
Positive inlet	If the installation has a positive inlet pressure, the pump is always primed, and the self-priming valve can be fully closed.	Removes sound associated with self-priming valve movement in installations with positive inlet pressure.

<sup>1</sup> This performance mode will result in some performance loss and a slight increase in noise level. Please refer to technical data for more information.

**9.2.3.1 Selecting the performance mode**

If the performance mode needs to be changed from the default setting, follow these steps:

1. Remove the pump cover.
  - a. Unscrew and remove the priming plug from the pump.
  - b. Loosen and remove the inlet and outlet connections from the pump.
  - c. Loosen and pull away the pump cover to remove it from the pump.

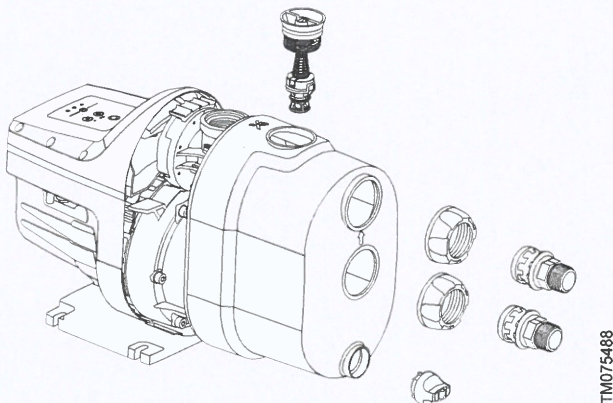

Remove the pump cover

2. Locate the performance mode knob.
3. Using a size 10 hex key, turn the knob to the desired selection.

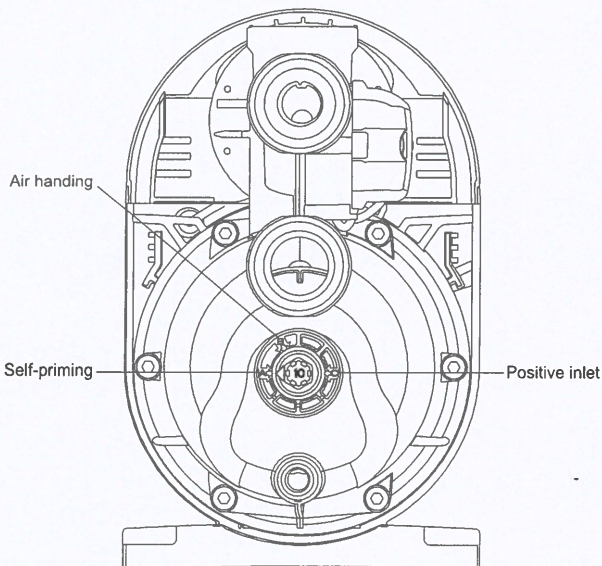

Rotate knob to select performance mode.

4. Return the pump cover and reconnect the priming plug and connections.

**9.3 Resetting to factory settings**

To reset the pump to factory settings via the HMI:

1. Press and hold [Enable/Disable] and [Reset] buttons simultaneously for 5 seconds.



Enable/Disable button



Reset button

It is also possible to reset to factory settings in Grundfos GO Remote.

**10. SCALA1 twin booster configuration**

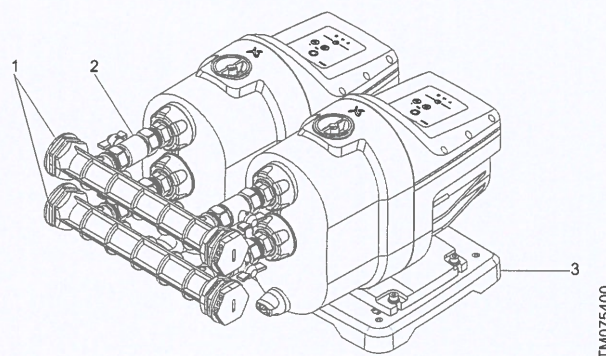

SCALA1 twin booster system

Pos.	Description
1	Inlet and outlet manifolds
2	Isolation valves
3	Twin base plate
Not pictured: communication cable and fixing screws	

SCALA1 can be easily set up as a twin boosting system by using the accessory set and Grundfos GO Remote.

In the twin setup, the two SCALA1 pumps communicate together via a cable included in the accessory set.

The twin boosting system is beneficial when the water flow demand is higher, or a system with a standby pump is required.

Once connected, a priority will be assigned automatically to the pumps.

In the twin booster configuration, an HMI on one pump will act as system HMI, meaning that all actions done on one pump HMI will be propagated to the other pump in the system.

All the alarms and functions of the pump are also available for the twin system.

**10.1 Operation modes and parameters**

Once SCALA1 is installed as a twin booster system, it can run in two different operation modes.

**Duty/Standby**

In Duty/Standby operation mode, only one pump will run at a time in the twin system. This means that the maximum performance of the system will be the same as the maximum performance of a single SCALA1 unit. In case one pump fails to start, the other one will run. The pumps will switch priority at the start based on the alternation settings.

## Duty/Assist

Running in Duty/Assist operation mode brings more flow on the outlet side, as both pumps can run at the same time. A pump with an assigned priority will start first and, in case it cannot deliver the necessary flow, the second pump will start. In case one pump fails to start, the system will continue running with one pump. The pumps will switch priority at the start based on the alternation settings.

Alternation can be set based on runtime or number of starts. This is done through the Grundfos GO Remote application, either in the initial setup or through the Settings tab on the Dashboard screen.



"No alternation" is only available for selection when operating in Duty/Assist.

## 10.2 Setting SCALA1 twin booster system

### WARNING

#### Electric shock

Death or serious personal injury



- Switch off the power supply before you start any work on the product. Make sure that the power supply cannot be switched on accidentally.

### WARNING

#### Electric shock

Death or serious personal injury



- The protective earth (PE) of the power outlet must be connected to the protective earth of the pump. The plug must have the same PE connection system as the power outlet.



All electrical connections must be carried out by qualified persons in accordance with local regulations.



If the power cable is damaged, it must be replaced by the manufacturer, the manufacturer's service partner or a similarly qualified person.



Make sure that the electrical installation supports the rated current [A] of the product. See the nameplate of the product.

Twin base plate, manifolds and communication cable are available in the SCALA twin accessory set.

To enable the twin operation of two SCALA1 pumps, follow the steps below.

1. Position both pumps on the twin base plate without fastening them.
2. Open the cover of both pumps by removing the screws.
3. Punch open the vacant hole/slot on the side of the pump body and pull one end of the communication cable through the hole.

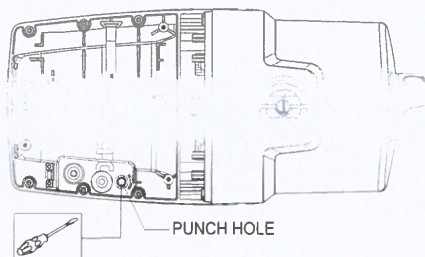

Punch hole for communication cable

4. Plug in the communication cable in the control board of the pump.

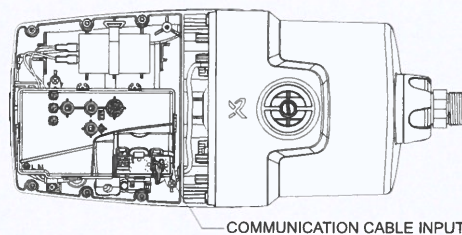

Connect communication cable

5. Connect the other end of the communication cable to the second pump according to the instructions in steps 2 - 4.
6. Fasten both pumps to the base plate.
7. Connect the inlet and outlet manifolds to both pumps.
8. Prime both pumps according to the priming instructions.

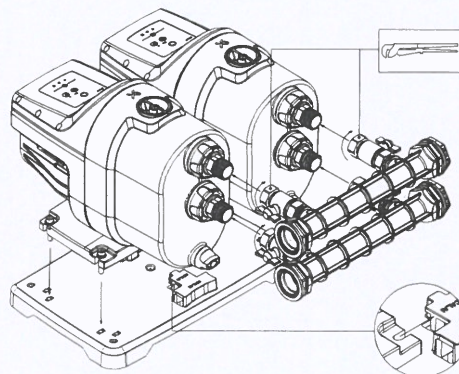

Fasten pumps to base plate and connect inlet and outlet manifolds

9. Follow the startup instructions.
10. Connect to Grundfos GO Remote and follow the initial setup screen.
11. Press the connect button on the operating panel of one of the pumps to establish the connection between the twin pumps
12. Follow the instructions in Grundfos GO Remote for setting up the twin booster system.

### 10.2.1 Setting SCALA1 twin booster with Grundfos GO Remote

Setting the twin booster with Grundfos GO Remote can be done in two ways:

- initial setup: run on first connection, or through the assist tab in the Dashboard
- settings tab in the Dashboard.

Choose the correct parameters for:

- operation mode
- alternation type
- alteration value.

- If the SCALA1 booster system is set up as Duty/Standby with alternation on the number of starts = 1, this means that every time the system starts a different pump is running.
- If the SCALA1 booster system is set up as Duty/Standby with alternation on the number of starts = 5, this means that pump 1 will start first for 5 times before switching the priority to pump 2.
- If the SCALA1 booster system is set up as Duty/Assist with alternation on runtime = 5h, this means that pump 1 will start first every time until the system reaches 5 hours of operating time. Then the priority will be swapped between pumps.

TM075388

TM075386

TM075385

**Range and default values for alternation**

	Minimum	Default	Maximum	Resolution
Alternation of starts and stops	1	1	100	1
Alternation runtime [h]	0.5	5	100	0.5

**11. Service****WARNING****Electric shock**

Death or serious personal injury



- Switch off the power supply before you start any work on the product. Make sure that the power supply cannot be switched on accidentally.

**WARNING****Chemical hazard**

Death or serious personal injury



- Make sure that the product has only been used for water. If the product has been used for pumping aggressive liquids, flush the system with clean water before you start work on the product.

**WARNING****Biological hazard**

Death or serious personal injury



- Make sure that the product has only been used for water. If the product has been used for pumping aggressive liquids, flush the system with clean water before you start work on the product.

**WARNING****Pressurised system**

Death or serious personal injury



- Before dismantling the pump, drain the system or close the isolating valves on both sides of the pump. Slowly loosen the drain plug and unpressurise the system.

**CAUTION****Impurities in the water**

Minor or moderate personal injury



- Before the pump is used for supplying drinking water, flush the pump thoroughly with clean water.
- Use spare parts approved by Grundfos.



Only qualified persons are allowed to service the pump.

**11.1 Maintenance**

The pump is maintenance-free, but we recommend that you check and clean the condensation plugs and integrated non-return valve once per year or as needed.

**11.1.1 Cleaning of condensation plugs**

1. Remove the condensation plugs carefully with a suitable tool, for example, a small screwdriver
2. Rinse the condensation plugs with water.
3. Reinsert the condensation plugs carefully by pressing them in place with a finger.

**Example:**

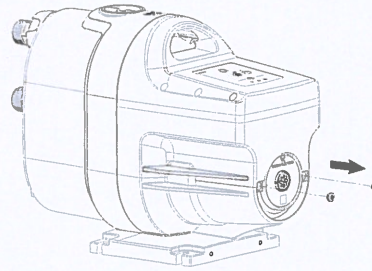

*Cleaning the condensation plugs*

**11.1.2 Cleaning of the integrated non-return valve**

1. Turn off the power supply and disconnect the power plug.
2. Shut off the water source.
3. Open the tap to release the pressure in the pipe system.
4. Close the isolating valves and/or drain the pipes.
5. Gradually open and remove the priming plug. The plug and non-return valve are one unit.
6. Clean the integrated non-return valve with warm water and a soft brush.
7. Assemble the components in reverse order.

**Example:**

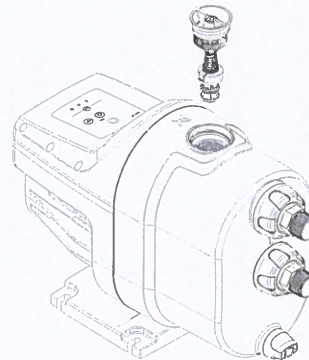

*Integrated non-return valve*

**11.2 Customer service information**

For further information on service parts, see Grundfos Product Center on [www.product-selection.grundfos.com](http://www.product-selection.grundfos.com).

**11.3 Service kits**

For further information on service kits, see Grundfos Product Center on [www.product-selection.grundfos.com](http://www.product-selection.grundfos.com).

**12. Starting up after standstill****WARNING****Electric shock**

Death or serious personal injury



- Switch off the power supply before you start any work on the product. Make sure that the power supply cannot be switched on accidentally.

TM075337

TM075336



**WARNING**  
**Electric shock**

Death or serious personal injury

- Check that the product is intact and not cracked. Especially if the product was not drained before standstill or was exposed to frost.

**CAUTION**  
**Impurities in the water**

Minor or moderate personal injury

- Before the pump is used for supplying drinking water, flush the pump thoroughly with clean water.

If the product has been standing still for a period of time, for example, during winter, follow these instructions before startup.

1. Check that the product is intact and not cracked. Especially if the product was not drained before standstill or has been exposed to frost.
2. Check that the pump is not blocked by following the deblocking instructions.
3. Before the pump is used for supplying drinking water, flush the pump thoroughly with clean water.
4. If the pump has been drained, it must be filled with liquid before startup. Follow the priming instructions.
5. Follow the startup instructions. The pump will remember the controller settings even if it is turned off.

**12.1 Deblocking the pump****WARNING**  
**Electric shock**

Death or serious personal injury

- Switch off the power supply before you start any work on the product. Make sure that the power supply cannot be switched on accidentally.

**WARNING**  
**Moving parts**

Death or serious personal injury

- Make sure that the product cannot start unexpectedly while deblocking the pump shaft.

1. Remove the plug incorporated in the end cover. Use a suitable tool to remove the plug.
2. Deblock the pump shaft if it has seized up as a result of inactivity.

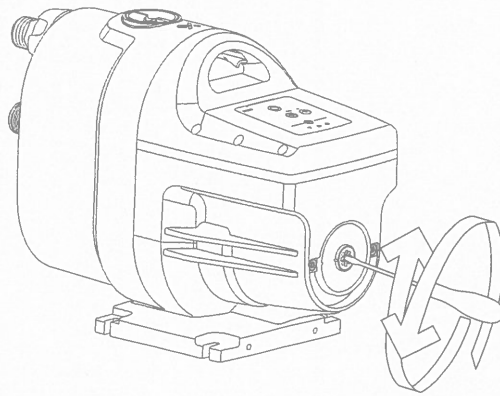
**Example:**

TM075258

*Deblocking the pump***13. Taking the product out of operation****WARNING**  
**Electric shock**

Death or serious personal injury

- Switch off the power supply before you start any work on the product. Make sure that the power supply cannot be switched on accidentally.

If the product is taken out of operation for a period of time, for example, during winter, it must be disconnected from the power supply and placed in a dry location.

Follow these steps:

1. Disconnect the product from the power supply.
2. Open a tap to release the pressure in the pipe system.
3. Close the isolating valves and drain the pipes.
4. Gradually loosen the drain plug to release the pressure in the product.
5. Drain the product by removing the drain plug.
6. Store the product according to the recommended storing conditions.

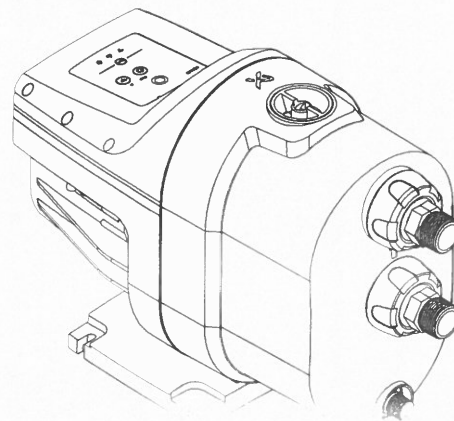
**Example:**

TM 075258

*Draining the pump***14. Storage**

The storage location must be protected from rain, humidity, condensation, direct sunlight and dust.



The product is not frost resistant. Store the product in a frost-free location.



Drain the product before storage.

If the product is to be stored for a certain period of time, for example, during winter, drain it by removing the drain plug and store the product indoors in a dry location.

Temperature range during storing must be from -40 to 70 °C (-40 to 158 °F).

Maximum relative humidity during storage: 95 % RH.

### 15.1 Grundfos Eye SCALA1

Grundfos Eye indicates the operating conditions of the motor on the motor operating panel.

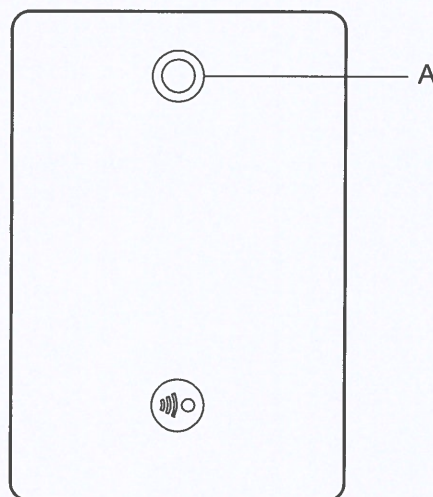

TM054846

## 15. Fault finding

### CAUTION

#### Hot surface

Minor or moderate personal injury



- Do not run the pump continuously with a closed inlet or outlet valve.

### CAUTION

#### Hot or cold liquid

Minor or moderate personal injury







- Make sure that escaping hot or cold liquid does not cause injury to persons or damage to the equipment.

### Grundfos Eye indicator light

Grundfos Eye	Cause	Remedy
	No lights are on.	The power is off. The motor is not running.
	Two opposite green lights are permanently on.	The power is on. The motor is not running.
	Two opposite green lights are rotating.	The power is on. The motor is running. The indicator lights are rotating in the direction of rotation of the motor when seen from the non-drive end.
	Two opposite red indicator lights are flashing simultaneously.	Alarm. The motor has stopped.
	Two opposite yellow lights are permanently on.	The pump was stopped by external input, calendar function or twin communication failure.
	Two yellow and four green lights are permanently on.	The pump is performing a self-test.











## 15.2 The pump does not start

Grundfos Eye	Indicator light	Automatic reset	Cause	Remedy
	-	-	The fuses in the electrical installation have blown.	Replace the fuses. If the new fuses blow as well, check the electrical installation.
	-	-	The earth leakage circuit breaker or the voltage-operated circuit breaker has been tripped.	Cut in the circuit breaker.
	-	-	No power supply.	Contact the power supply authorities.
	-	-	The difference between SCALA1 unit and the tapping point is too large.	Adjust the installation or select a SCALA1 unit with a higher head.





Cause

Remedy



## 15.3 The pump is not running

Grundfos Eye	Indicator light	Automatic reset	Cause	Remedy
	-	-	Power supply failure.	Switch on the power supply. Check the cables and cable connections for defects and loose connections. Check for blown fuses in the electrical installation.
		Yes	Dry-running or water shortage.	Check the water source, and prime the pump.
			Impurities are blocking the inlet pipe.	Clean the inlet pipe.
			The foot or non-return valve is blocked in a closed position.	Clean, repair or replace the foot or non-return valve.
			Leakage in the inlet pipe.	Repair the inlet pipe.
			Air in the inlet pipe or the pump.	Prime the inlet pipe and the pump. Check the inlet conditions of the pump.
		No	Maximum runtime has been exceeded.	Check the installation for leakage and reset the alarm.
		Yes	The internal non-return valve is defective or blocked in completely or partially open position.	Clean, repair or replace the non-return valve.
			Small leakage is detected by the anti-cycling function. Alarm is on.	Check the taps and reconsider the usage pattern, e.g. ice machines, water evaporators for air-conditioning, etc.
	-	No	The shaft seal is seized up.	
			The pump is blocked by impurities.	See section 10. Starting up the product after the standstill.
	No	No	Overheating due to seized-up or choked-up pump.	Contact your pump supplier
	No	No	Too low or too high supply voltage.	Check the supply voltage and correct the fault, if possible.
	No	-	The pump has been stopped by external input or calendar function.	





**Cause** **Remedy** **15.4 The pump is running**

Grundfos Eye	Indicator light	Automatic reset	Cause	Remedy
		No	The non-return valve is not properly closed, or the pipe system is leaking. This happens when cycling alarm and/or leakage alarm are disabled.	Check and repair the pipe system, or clean, repair or replace the non-return valve.
		No	Small continuous consumption.	Check the taps and reconsider the usage pattern (ice machines, water evaporators for air-conditioning, etc.).



**Cause** **Remedy** **15.5 The pump cuts out during operation**  
**Condition**

Grundfos Eye	Indicator light	Automatic reset	Cause	Remedy
	-	-	Overheating due to excessive liquid temperature above 45 °C.	Supply cold liquid to the pump.
	-	-	Overheating caused by – high ambient temperature 55 °C – overloaded motor – seized-up motor or pump.	Contact your pump supplier.
	-	-	Supply voltage too low.	Check the supply voltage and correct the fault, if possible.



**Cause** **Remedy** **15.6 The pump performance is insufficient**

Grundfos Eye	Indicator light	Automatic reset	Cause	Remedy
	-	-	Pump inlet pressure is too low.	Check pump inlet conditions.
	-	-	Pump is undersized.	Replace the pump with a larger pump.
	-	-	Inlet pipe, inlet strainer or pump are partially blocked by impurities.	Clean the inlet pipe or the pump.
	-	-	Leakage in the inlet pipe.	Repair the inlet pipe.
	-	-	Drive the inlet pipe and the pump. Check pump inlet conditions.	Drive the inlet pipe and the pump. Check pump inlet conditions.

Cause	Remedy	15.7 The pump starts and stops too frequently
-------	--------	---

Grundfos Eye	Indicator light	Automatic reset	Cause	Remedy
	-	-	Leakage in suction pipe or air in the water.	Restore the water supply or repair suction pipe.
	-	-	A tap has not been closed entirely after use.	Check that all taps have been closed. See section Anti-cycling.
	-	-	Minor leakage in the system.	Check the system for leakages. See section Anti-cycling.

Cause	Remedy	15.8 The pump does not stop
-------	--------	-----------------------------

Grundfos Eye	Indicator light	Automatic reset	Cause	Remedy
	-	-	The pump cannot deliver the necessary discharge pressure.	Replace the pump.
	-	-	The existing pipes are leaking or defective.	Repair the pipes.
	-	-	The non-return valve is blocked or missing.	Clean the valve or fit a non-return valve.

Cause	Remedy	15.9 The pump gives electric shocks
-------	--------	-------------------------------------

Grundfos Eye	Indicator light	Automatic reset	Cause	Remedy
-	-	-	Defective earth connection.	Connect the earth connection to the pump according to local regulations.

Cause	Remedy	15.10 Twin booster system fault finding
-------	--------	---

In twin configuration, the same fault finding applies.

SCALA1 alarms act in the following way:

- Dry-run alarm: Pump alarm: stops one pump first and then the other in case of dry-running.
- Max. runtime: System alarm: stops the entire system.
- Cycling protection: System alarm: stops the entire system.

#### Pumps deliver different performances

Grundfos Eye	Indicator light	Automatic reset	Cause	Remedy
	-	-	Two different models of SCALA1 connected.	Connect the same size models.

#### Only one pump is operating in the twin pump system

Grundfos Eye	Indicator light	Automatic reset	Cause	Remedy
	-	-	Communication failure.	Check the system and each pump using the fault finding above. Check or replace the twin communication cable.

Cause	Remedy
	<ol style="list-style-type: none"> <li>1. Eliminate the fault cause and reset the pump manually by pressing the [Reset] button.</li> <li>2. Enable the <b>Auto reset</b> function.</li> </ol>

#### 15.11 Fault resetting

A fault indication can be reset in one of the 2 following ways:

**Example:**



If the fault disappears by itself, the pump will attempt to reset automatically, and the fault indication will disappear. The fault indication will still be visible in the Grundfos GO Remote alarm log.

## 16. Technical data

### 16.1 Operating conditions

SCALA1					
	3-25	3-35	3-45	5-25	5-55
Max. ambient temperature	55 °C (131 °F)	55 °C (131 °F)	55 °C (131 °F)	55 °C (131 °F)	55 °C (131 °F)
Max. liquid temperature	45 °C (113 °F)	45 °C (113 °F)	45 °C (113 °F)	45 °C (113 °F)	45 °C (113 °F)
Maximum system pressure [bar (psi)]	8 (116)	8 (116)	8 (116)	8 (116)	8 (116)
Maximum inlet pressure [bar (psi)]	5 (72.5)	4 (58)	3 (43.5)	5 (72.5)	2 (29)
Max. head [m (ft)] 50 Hz	25 (82)	36 (118.1)	44 (144.3)	26 (85.3)	52 (170.6)
Max. head [m (ft)] 60 Hz	25 (82)	35 (114.8)	51 (167.3)	27 (85.3)	53 (173.8)
Nominal head [m (ft)]	15 (49.2)	20 (65.6)	25 (82)	15 (49.2)	25 (82)
Nominal flow [m <sup>3</sup> /h (gpm)]	3.00 (12.19)	3.72 (16.38)	3.59 (15.80)	4.80 (21.12)	5.33 (23.48)
IP Rating	X4D	X4D	X4D	X4D	X4D
Pumped liquid	Clean water	Clean water	Clean water	Clean water	Clean water
Noise level [db(A)]	< 55	< 55	< 55	< 55	< 55
Frequency of starts and stops	25 per hour	25 per hour	25 per hour	25 per hour	25 per hour
Start pressure (pstart) [bar (psi)]	1.2 (17.4)	1.5 (21.8)	2.2 (31.9)	1.2 (17.4)	2.8 (40.6)

### 16.2 Mechanical data

Pipe connections are R1" or NPT1".

## 16.3 Electrical data

All variants have insulation class F.

### 50 Hz

Pump type	Voltage [V]	P1 [W (hp)]	P2 [W (hp)]	n [rpm]	I <sub>n</sub> [A]	I <sub>start</sub> [A]	Standby power [W]
SCALA1 3-25	1 x 230	550 (0.74)	360 (0.50)	2850	2.58	13.0	1.5
SCALA1 3-35	1 x 230	720 (0.97)	450 (0.60)	2800	3.27	13.0	1.5
SCALA1 3-45	1 x 230	910 (1.23)	580 (0.80)	2800	4.10	17.0	1.5
SCALA1 5-25	1 x 230	650 (0.88)	425 (0.60)	2850	3.00	13.0	1.5
SCALA1 5-55	1 x 230	1200 (1.62)	780 (1.00)	2850	5.38	26.0	1.5

### 60 Hz

Pump type	Voltage [V]	P1 [W (hp)]	P2 [W (hp)]	n [rpm]	I <sub>n</sub> [A]	I <sub>start</sub> [A]	Standby power [W]
SCALA1 3-25	1 x 230	540 (0.72)	350 (0.50)	3450	2.37	13.0	1.5
	1 x 115	560 (0.75)	350 (0.50)	3450	5.10	29.5	1.5
SCALA1 3-35	1 x 230	650 (0.88)	470 (0.60)	3400	2.76	13.0	1.5
	1 x 115	650 (0.88)	470 (0.60)	3400	5.71	29.5	1.5
SCALA1 3-45	1 x 230	870 (1.17)	570 (0.80)	3350	3.72	15.5	1.5
	1 x 115	950 (1.28)	590 (0.80)	3400	8.62	40.0	1.5
SCALA1 5-25	1 x 230	600 (0.80)	420 (0.60)	3450	2.60	13.0	1.5
	1 x 115	610 (0.82)	450 (0.60)	3450	5.70	29.5	1.5
SCALA1 5-55	1 x 230	1250 (1.68)	810 (1.10)	3450	5.25	22.5	1.5
	1 x 115	1250 (1.68)	860 (1.10)	3450	11.57	64.0	1.5

## 16.4 Dimensions and weights

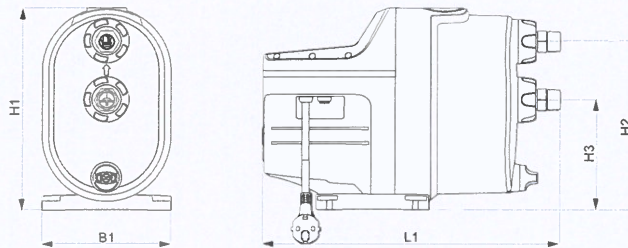

TM075267

Pos.	H1	H2	H3	L1	B1
	[mm] [inch]	[mm] [inch]	[mm] [inch]	[mm] [inch]	[mm] [inch]
SCALA1 (all variants)	316 12.4	263 10.4	171 6.7	466 18.4	202 8.0

### Weight

SCALA1 3-25 [kg]	SCALA1 3-35 [kg]	SCALA1 3-45 [kg]	SCALA1 5-25 [kg]	SCALA1 5-55 [kg]
[lb]	[lb]	[lb]	[lb]	[lb]
11	12	12	12	14
24.2	26.4	26.4	26.4	30.8



16.5 Air handling mode performance curves

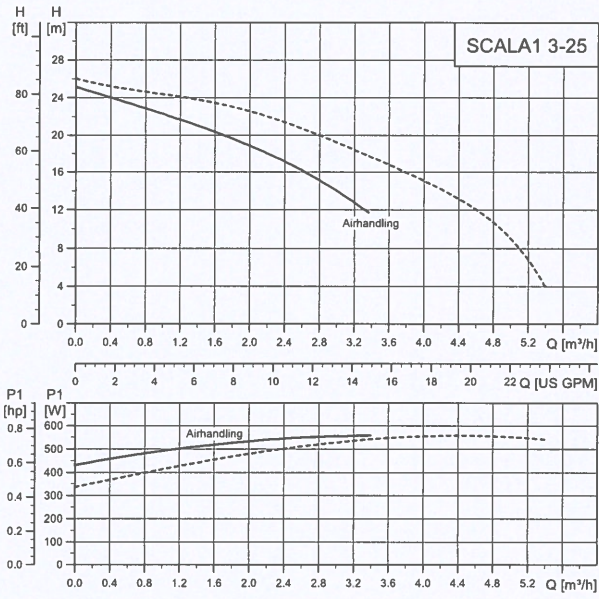

TM075233

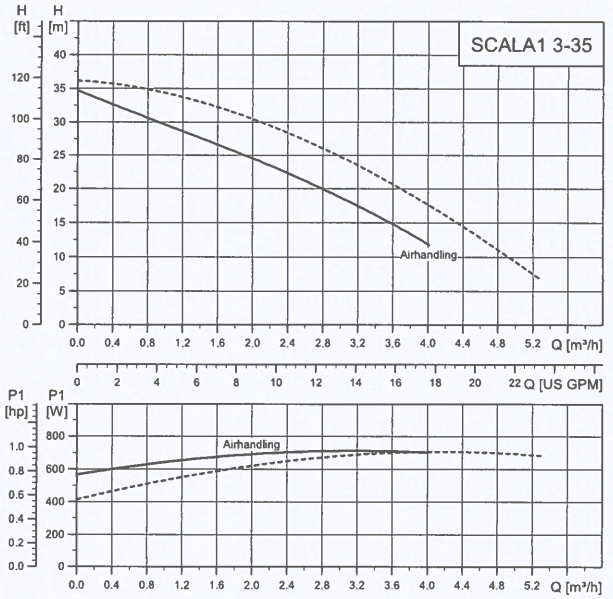

TM075234

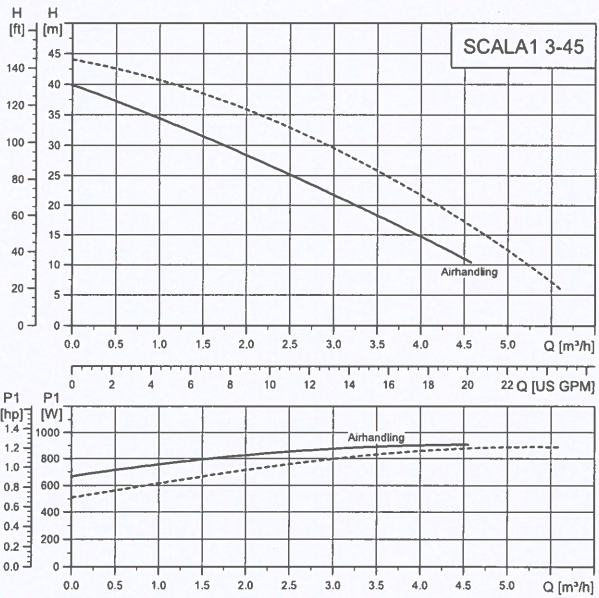

TM075235

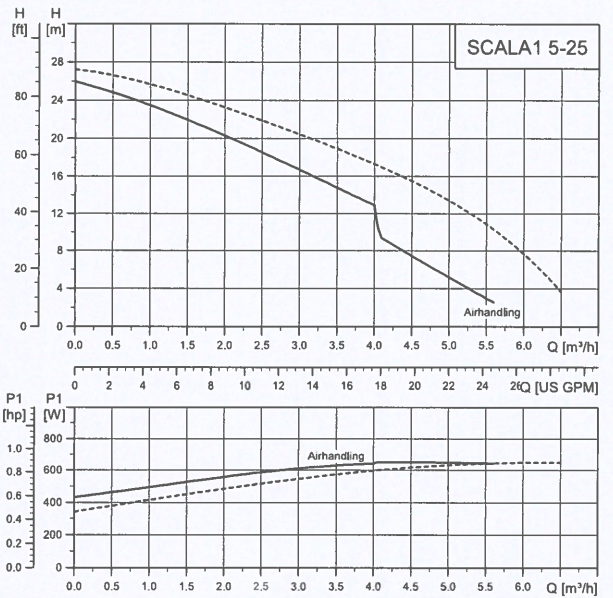

TM075236

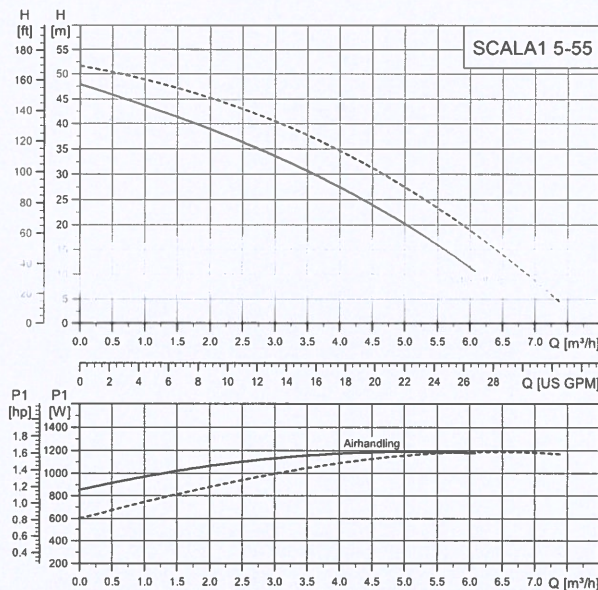

TM075237

## 17. Approvals

### 17.1 Bluetooth technology information

Frequency of operation	2400 – 2483.5 MHz (ISM band)
Modulation Type	GFSK
Data Rate	1 Mbps
Transmit power	5 dBm EIRP with internal antenna

For Brazil only: This pump has a BLE ANT board equipped with Bluetooth technology with these specifications.

### 17.2 FCC/ISED general requirements

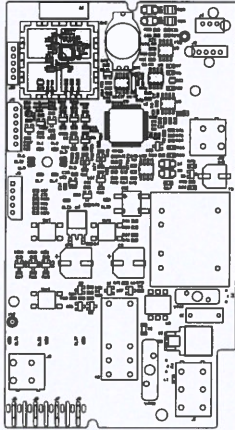

TM075015

FCC ID:OG3-SCALA1, IC:10447A-SCALA1

This device complies with FCC and ISED radiation exposure limits set forth for an uncontrolled environment. This device must be installed and operated with a minimum distance of 20 cm (7.87 inches) between the radiator and your body. This transmitter must not be co-located or operated in conjunction with any other antenna or transmitter.

#### FCC

This device complies with Part 15 of the FCC Rules. Operation is subject to the following two conditions:



1. This device may not cause harmful interference, and
2. This device must accept any interference received, including interference that may cause undesired operation.



Changes or modifications made to this equipment not expressly approved by Grundfos may void the user's authority to operate this equipment.

#### ISED

This device complies with ISED's license-exempt RSSs. Operation is subject to the following two conditions:



1. This device may not cause harmful interference, and
2. This device must accept any interference received, including interference that may cause undesired operation.



Changes or modifications made to this equipment not expressly approved by Grundfos may void the user's authority to operate this equipment.

This radio transmitter (IC:10447A-GIM1A) has been approved by ISED to operate with Grundfos cellular module CIM 280-US (IC:10447A-CIM2X034G). Only the original Grundfos supplied antenna, part no. 99838775, is permitted.

This radio transmitter (IC:10447A-SCALA1) has been approved by ISED to operate with the antenna integrated into the device. Other antenna types are strictly prohibited for use with this device.

The maximum antenna gain is:

CDMA850/LTE B5	+0.3 dBi (824-849 MHz)
CDMA1900/LTE B2	-1.2 dBi (1850-1910 MHz)
LTE B4	+1.5 dBi (1710-1755 MHz)
LTE B17	-7.0 dBi (704-716 MHz)
LTE B12	-7.0 dBi (698-716 MHz)
LTE B13	-5.0 dBi (777-787 MHz)

#### Bluetooth information

Frequency of operation	2400 - 2483.5 MHz (ISM band)
Modulation type	GFSK
Data rate	1 Mbps
Transmit power	5 dBm EIRP with internal antenna

## 18. Disposing of the product

This product or parts of it must be disposed of in an environmentally sound way.

1. Use the public or private waste collection service.
2. If this is not possible, contact the nearest Grundfos company or service workshop.
3. Dispose of the waste battery through the national collective schemes. If in doubt, contact your local Grundfos company.



The crossed-out wheellie bin symbol on a product means that it must be disposed of separately from household waste. When a product marked with this symbol reaches its end of life, take it to a collection point designated by the local waste disposal authorities. The separate collection and recycling of such products will help protect the environment and human health.

See also end-of-life information at [www.grundfos.com/product-recycling](http://www.grundfos.com/product-recycling).

### 18.1 Disposing of hazardous or toxic materials

#### WARNING

#### Chemical hazard

Death or serious personal injury



- Observe the material safety data sheet of the dosing medium.
- Wear protective clothing when working on the dosing head, connections or lines.
- Rinse the parts that have been in contact with the dosing medium.
- Collect and dispose of all chemicals in a way that is not harmful to persons or the environment.

The materials used in DMX pumps do not pose any health risk to the person handling them. To identify the specific materials, check the type key on the product nameplate and read the explanation in the section Type key.

Observe also the product recycling page on <http://www.grundfos.com/products/product-sustainability/dmx.html>