

Fitting of mating flanges:

No packing is required if the mating flanges of the piping system are correct and in accordance with the below drawings.

If this is not the case washers or gaskets must be used to **prevent** the inside edge of the mating flange damaging the packing face of the rubber expansion joint.

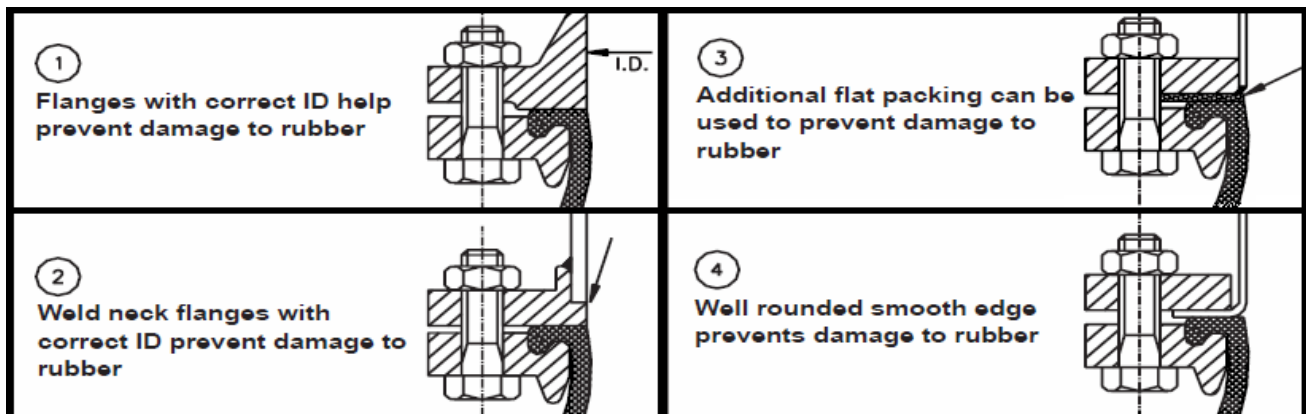

KE-Burgmann rubber expansion joints are always delivered with pre-fitted flanges. However, the correct bolt torque must be used when connecting the expansion joint to the pipe flange. The bolts should be tightened in sequences across the flanges, but should not bring the expansion joint flange into contact with the pipe flange.

Important:

Following installation, and before operating the plant, check that the bolts are tight, and re-torque as necessary (check again after 1 week, after 1 month, and then every 3 months).

Minor leaks from bolt holes can usually be cured by careful re-tightening.

If the above instructions are not followed, KE-Burgmann cannot under any circumstances accept any liability for damage.