

AQUABOOST

iMatic 800 Twin Pump Booster Set

The Aquaboost iMatic range of booster sets features one or two submersible multistage pumps controlled by a dedicated variable speed frequency inverter.

The twin pump 800 litre tank is fitted with two 0304 stainless steel pumps, capable of delivering flow rates up to 6.0 m³/hour per pump and capable of producing head pressures of up to 6.4 bar.

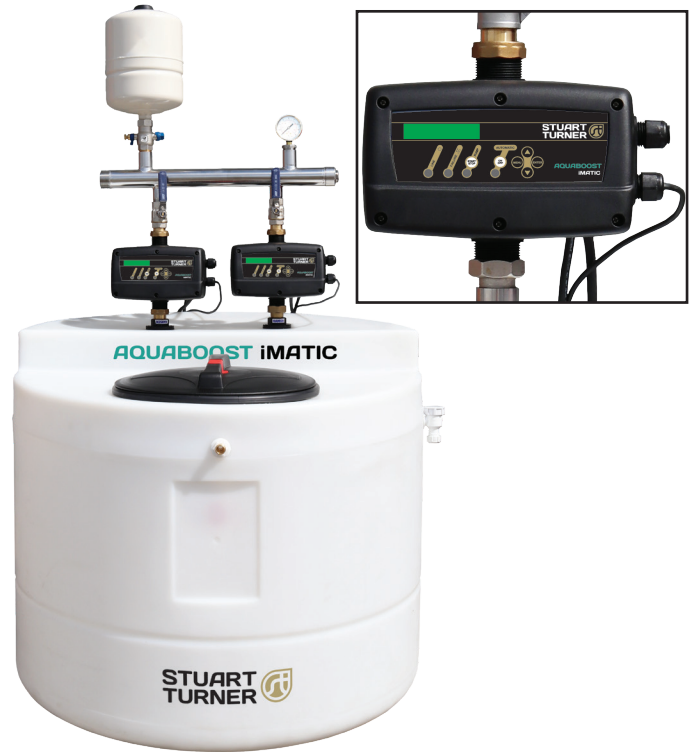

Features

- Flow rates up to 12.0 m³/h
- Head pressure up to 6.4 bar
- Twin 304 stainless steel pumps
- 800 litre plastic molded tank, constructed from WRAS approved material
- Dry run protection
- Stainless steel / brass discharge fittings
- Nickel plated WRAS approved ball valves
- Union fittings on controller
- WRAS approved 8 litre pressure vessel
- BMS volt free contacts

Application

- Cold water pressure and flow boosting in a range of domestic, commercial and industrial applications

Product Code Structure

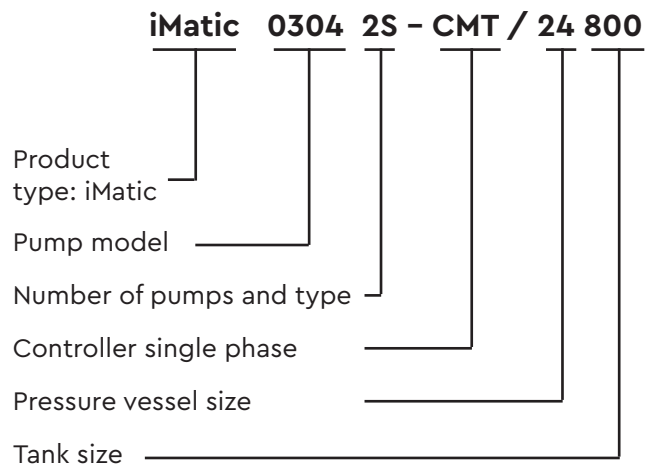

Performance Characteristics iMatic 0304 2S-CMT/24 800

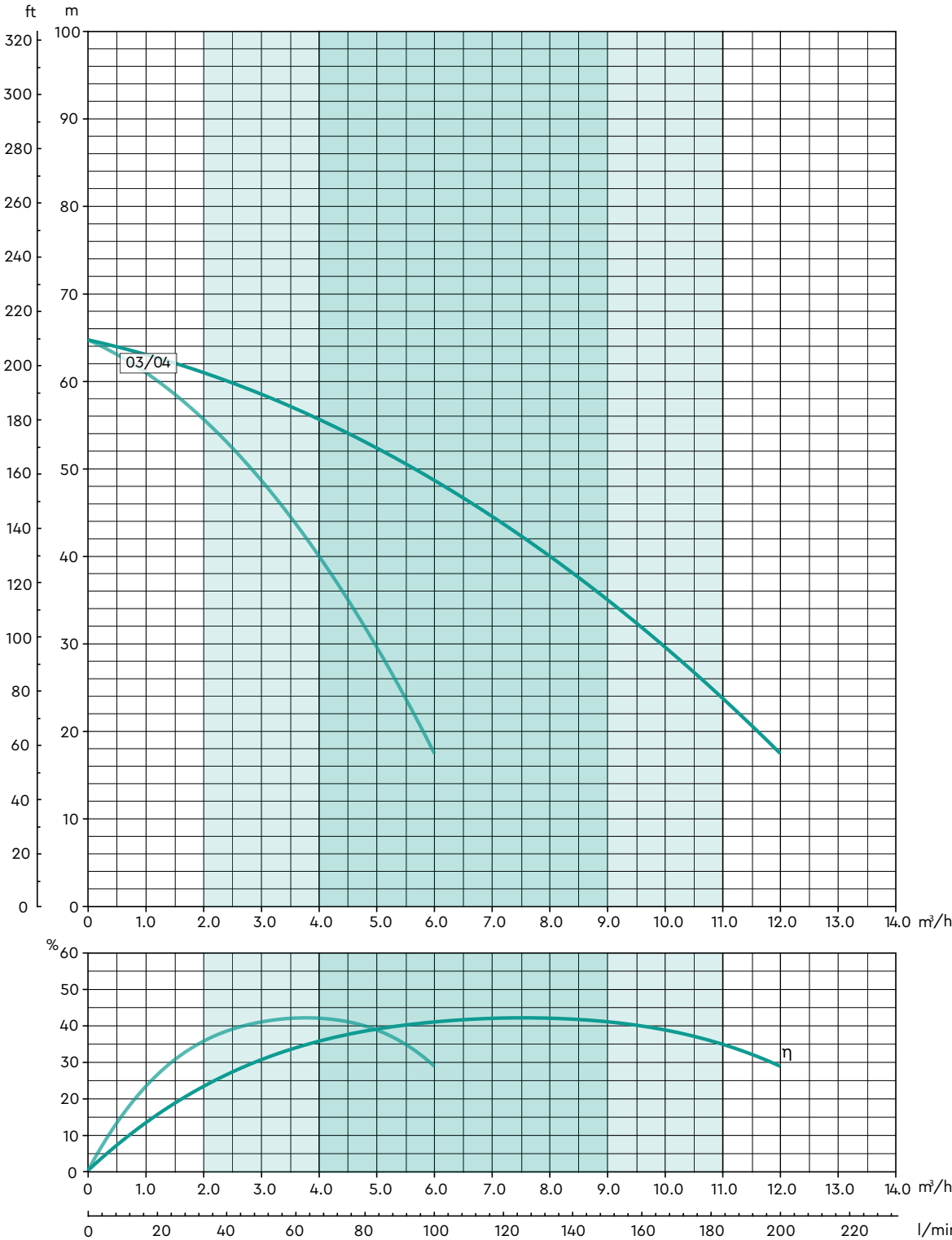

Technical Specification iMatic 0304 2S-CMT/24 800

		iMatic 0304 2S-CMT/24 800 47360	
General	Warranty		2 years
	Approvals		CE
	Typical noise		46 dB(A)
Features	Water tank air gap		Type AF
	Fluid category		CAT 3 / CAT 4
	Pump control system		Variable speed
	Pump control mode (twin pump)		Duty / Assist or Duty / Standby
	Dry run protection		✓
	Pressure Vessel		24 litre / 10 bar
	Pump check valve(s)		✓
	Flexible connection hose – outlet		Optional Extra
Performance	Nominal head*		4.4 bar
	Maximum head (closed valve)*		6.4 bar
	Nominal flow rate*		7.0 m ³ /h (3.5 m ³ /h per pump)
	Maximum flow rate*		12.0 m ³ /h (6.0 m ³ /h per pump)
	Ambient air temperature		0 – 40 °C
Water tank	Nominal water tank size		800 litres
	Usable water capacity		650 litres
	Float valve		WRAS Approved
	Water tank fill rate		30 l/min
Connections	Inlet connection		½" BSP
	Outlet connection		1 ½" BSP
	Overflow		22mm
Materials	Water tank		MDPE, food grade rated
	Water tank base		MDPE, food grade rated
Manifold	Manifold construction		Stainless Steel
	Pump isolation valves		WRAS Approved Full bore, lever
Pump	Pump type		Submersible multistage centrifugal
	Motor type		Induction, thermal protection
	Duty rating		Continuous
Electrical	Power supply / phase / frequency		16 A 230 V.a.c./1/50 Hz
	Full load current		12 Amps
Dimensions	Depth		1000 mm
	Width		1000 mm
	Height		1825 mm
Weight (dry/ filled)	Twin pump	Dry	75 Kg
		Filled	725 Kg

Dimensions iMatic 0304 2S-CMT/24 800

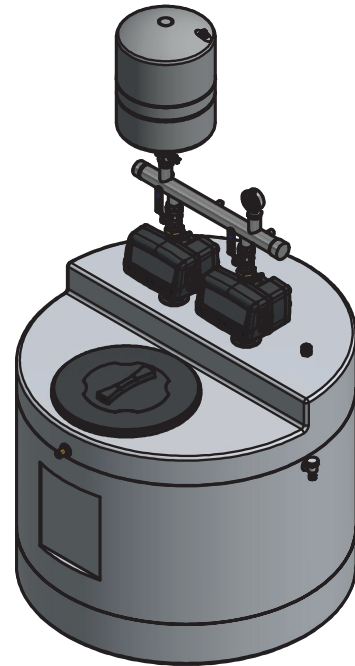
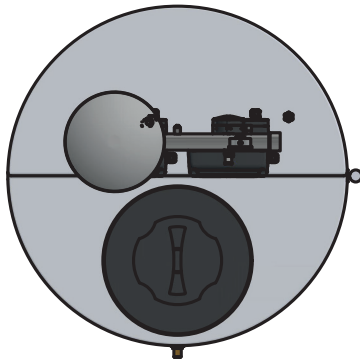
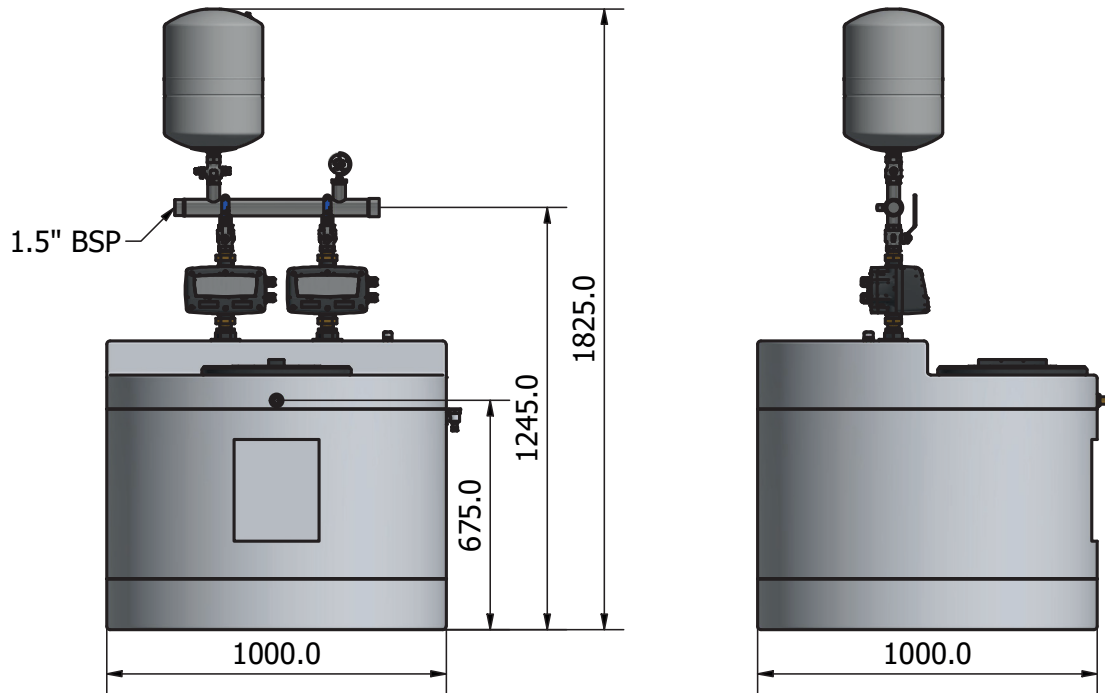

Scan QR Code for:

- Quick install information
- Operation & Maintenance manuals
- Wiring diagram
- Troubleshooting guides



Stuart Turner Limited reserves the right to amend specifications without notice.

Stuart Turner Ltd, Market Place, Henley-on-Thames, Oxfordshire, RG9 2AD

Tel: +44 (0) 1491 572655

www.stuart-turner.co.uk

Pt. No. 21149 Issue 4420/01-01