

STUART

ST 15/60 (130) Circulator 230 V

The Stuart ST 15/60 Circulator features the latest in high efficiency technology offering an EEI rating of just 0.18 and proportional pressure control.

For use in new systems or as a replacement unit, this cast iron circulator is suitable for heating systems.



Features

- ECM permanent magnet technology
- Constant speed (3 settings)
- Proportional pressure control
- Automatic venting cycle
- Robust cast iron housing
- Continuously rated
- Ceramic bearings
- 130 mm fitting length
- EuP/ErP compliant

This product is an ideal replacement for:

Grundfos: UPS2 15/50-60

Wilo: Yonos Pico 25/1/6

Dab: Evosta 40/70 130

CPL: CP60

Grundfos: UPS3 15/65

Application

- With a maximum performance of 3.3 m³/h and maximum head of 5.8 metres the ST 15/60 is a competitive solution to most domestic heating water return loop systems

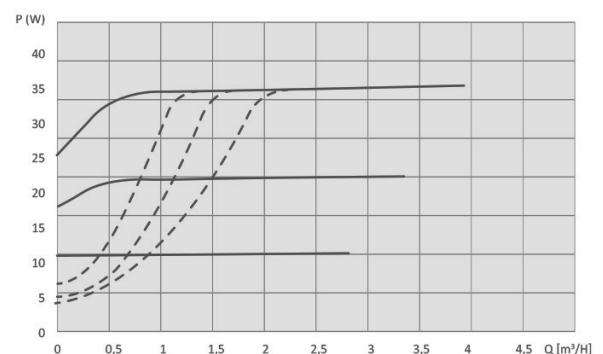
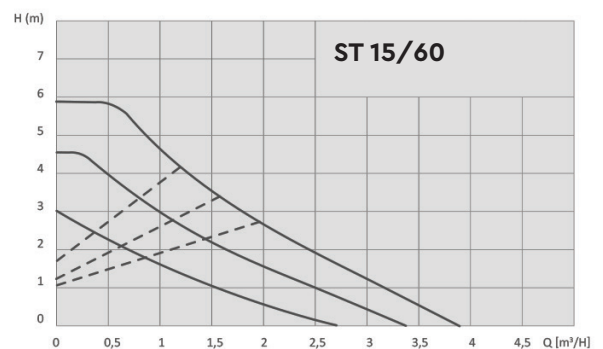

Pump Model		ST 15/60 (130) Circulator 230 V 47073				
General	Guarantee	5 year				
Features	Pump type	Centrifugal				
	Fitting length	130 mm				
	Speed settings	3				
Materials	Pump body	Cast iron				
	Impeller	Noryl				
	Bearings	Ceramic				
Performance	Maximum head (closed valve)	5.8 metres				
	Maximum flow	3.3 m ³ /h				
	Maximum working pressure*	10 bar				
	Min. inlet pressure	0.05 bar <75 °C (fluid temperature) 0.28 bar <90 °C (fluid temperature)				
	Maximum ambient air temperature	35	50	60	70	°C
	Max water temperature	110	100	90	80	°C
Connections	Pump connections	Rp 1½ "				
Motor	Type	Canned rotor				
	Duty rating	Continuous (S1)				
Electrical	Power supply / phase / frequency	230 V a.c. / 1 / 50 Hz				
	Power consumption	36 Watts (max.)				
	Current (full load)	0.32 Amps				
	Fuse rating	5 Amps				
	Insulation class	F				
	EI	0.18				
	Efficiency	38 %				
Physical	Enclosure protection	IP44				
	Length	132 mm				
	Width	125 mm				
	Height	130 mm				
	Weight	2.2 Kg				

* The maximum pressure that can be applied to the unit under any installation conditions.

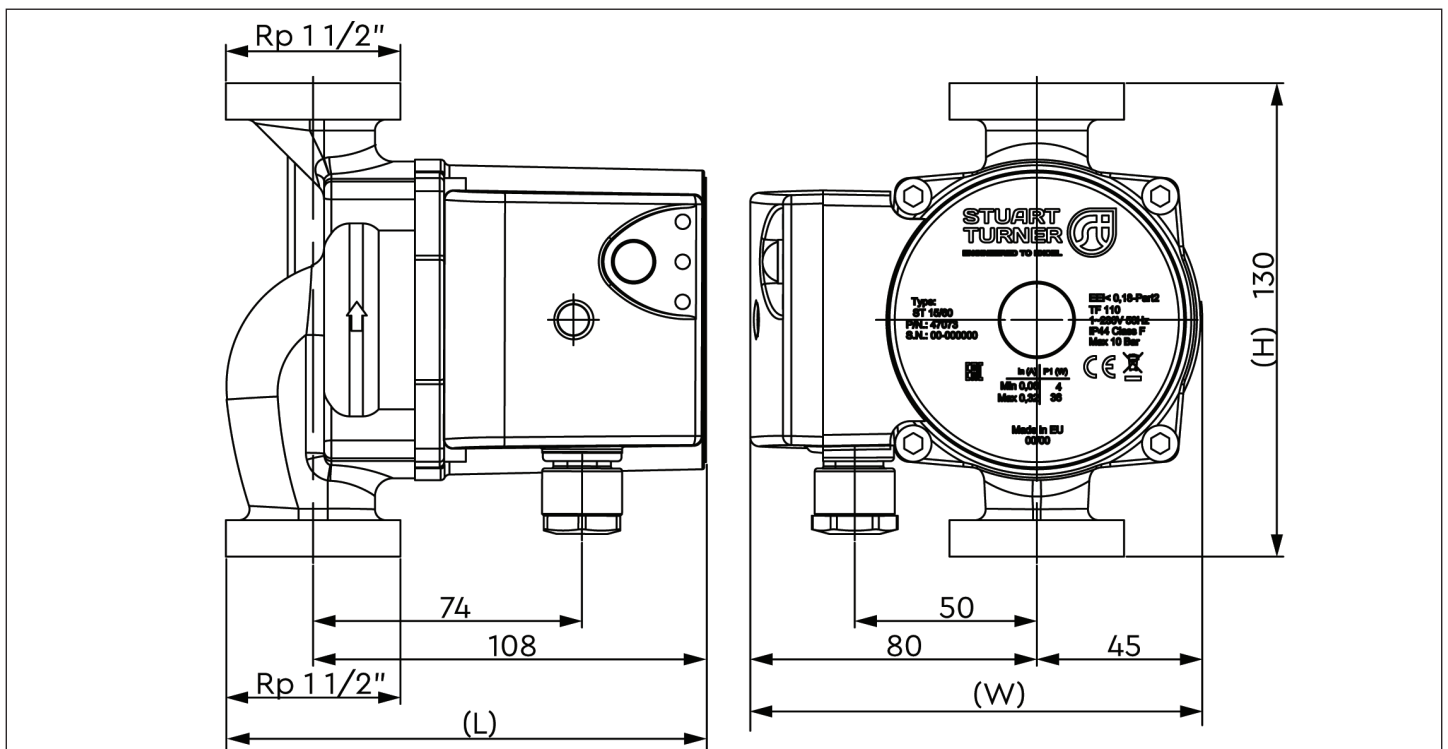

Stuart Turner Limited reserves the right to amend specifications without notice.

Stuart Turner Ltd, Henley-on-Thames, Oxfordshire RG9 2AD Tel: +44 (0) 1491 572655 Fax: +44 (0) 1491 573704
TechAssist Helpline +44 (0) 800 31 969 80
www.stuart-turner.co.uk

Pt. No. 20886 Issue 3619/1-02