

50 Hz



e-LNE Series

SINGLE IN-LINE ELECTRIC PUMPS
EQUIPPED WITH **IE3** MOTORS

ErP 2009/125/EC

Cod. 191007431 Rev. B Ed.12/2014

 **LOWARA**
a xylem brand

Xylect™

Xylect™ is a pump solution software with an extensive online database of product information across the entire range of pumps and related products, with multiple search options and helpful project management facilities. The system holds up-to-date product information on thousands of products and accessories.

Xylect™ can be available:

On the website – www.xylect.com

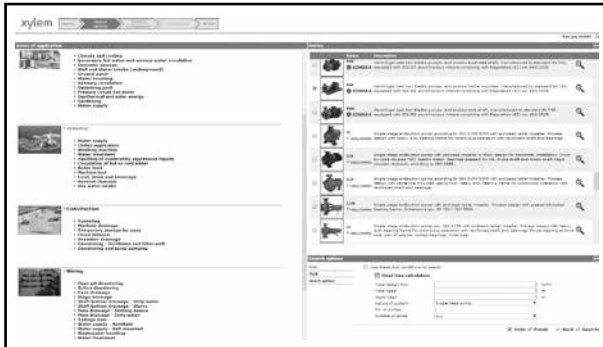

On DVD – Loop 4U

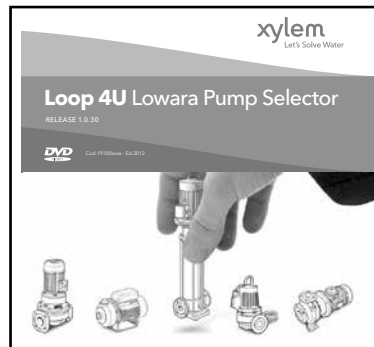

On Mobile Apps



For more information, please, see page 105-106.

Ecodesign Directive (ErP)

Over last decade the European Commission with the 'Energy Efficiency Plan' pushed the European Parliament and the Council to adopt specific measures to the purpose of reducing energy consumption and further negative environmental impacts.

Through the Directives 2005/32/EC, energy-using products (EuP), and 2009/125/EC, energy-related products (ErP) a framework for **ecodesign** requirements was established.

The Commission Regulations (EC) No 640/2009 and (EU) No 4/2014 have implemented two directives with regard to ecodesign requirements for **three-phase 50 Hz electric motors** placed on the market and put into service inside EU zone as self-alone units or integrated in other products.

This regulation states that motors must have **efficiency level IE3** (or IE2 + Variable Speed Drive) from **1st January 2015 for 7,5 to 375 kW** rated powers and from **1st January 2017 for 0,75 to 375 kW** ones.

The Commission Regulation (EU) No 547/2012 has implemented two directives with regard to ecodesign requirements for some types of **clean water pumps** placed on the market and put into service inside EU zone as self-alone units or integrated in other products.

This regulation states that water pumps shall have **index MEI 0.4** as minimum from **1st January 2015**. That index comes from a dedicated formula which considers hydraulic efficiency values at 'best efficiency point' (BEP), 75 % of the flow at BEP (Part load – PL) and 110 % of the flow at BEP (Over load – OL).

The Lowara e-LNE series, for the models in the scope of the regulations above, is ErP compliant, having an index MEI equal or higher than 0,4 and IE3 motor efficiency.

CONTENTS

General Introduction	5
Applications	6
Identification code	8
Rating plate	9
List of Models at 50 Hz, 4 poles	10
Pump cross-section and main components	12
Mechanical seals	14
Motors (ErP 2009/125/EC).....	15
Pumps (ErP 2009/125/EC).....	21
Minimum efficiency index (MEI)	22
Hydraulic performance range at 50 Hz, 2 poles	23
Table of hydraulic performances at 50 Hz, 2 poles	24
Hydraulic performance range at 50 Hz, 4 poles	26
Table of hydraulic performances at 50 Hz, 4 poles	27
Operating characteristics at 50 Hz, 2 poles	30
Operating characteristics at 50 Hz, 4 poles	48
Dimensions and weights	73
LNE..H (e-LNE with HYDROVAR)	89
Accessories	93
Report and declarations	97
Technical appendix	99

e-LNE SERIES

HYDRAULIC PERFORMANCE RANGE AT 50 Hz, 2 POLES

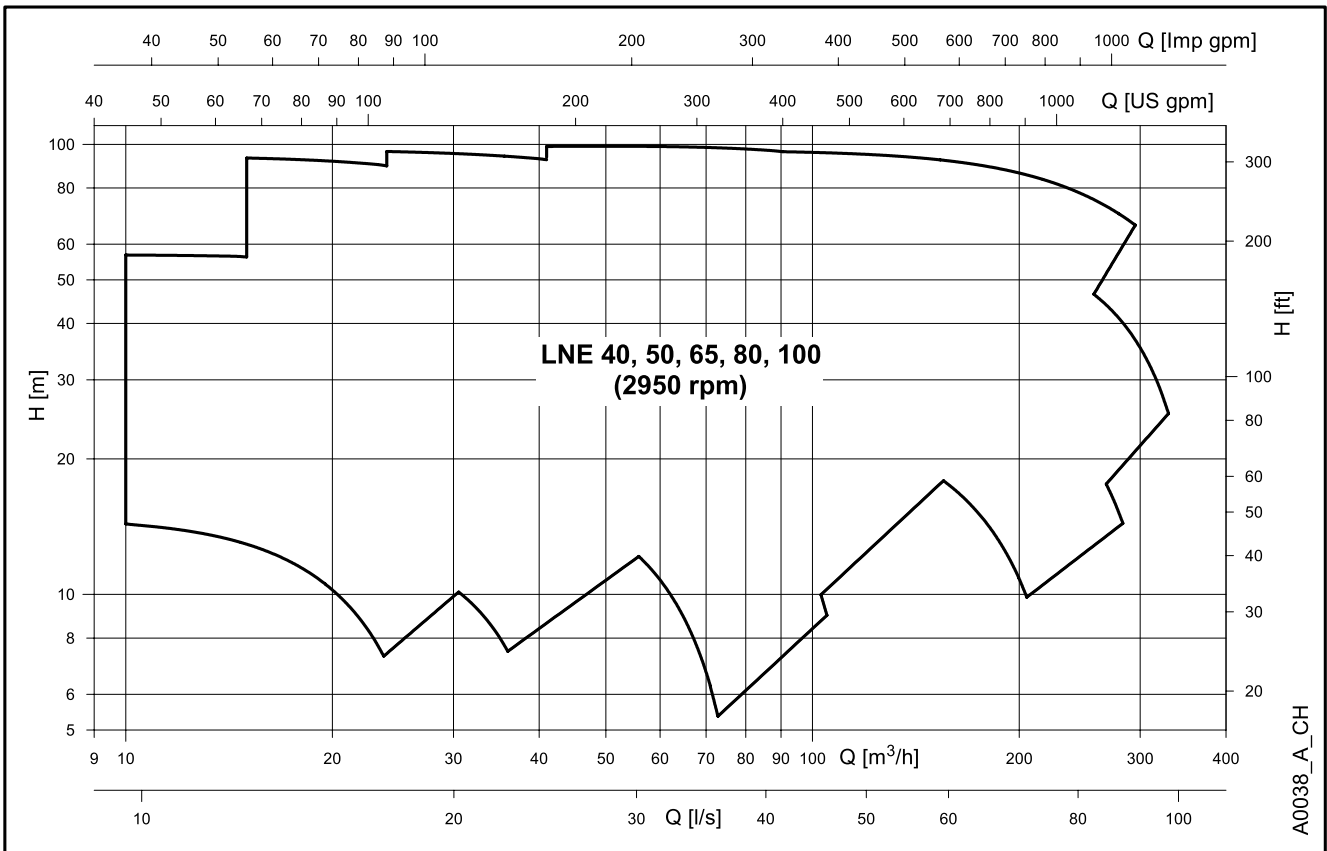

HYDRAULIC PERFORMANCE RANGE AT 50 Hz, 4 POLES

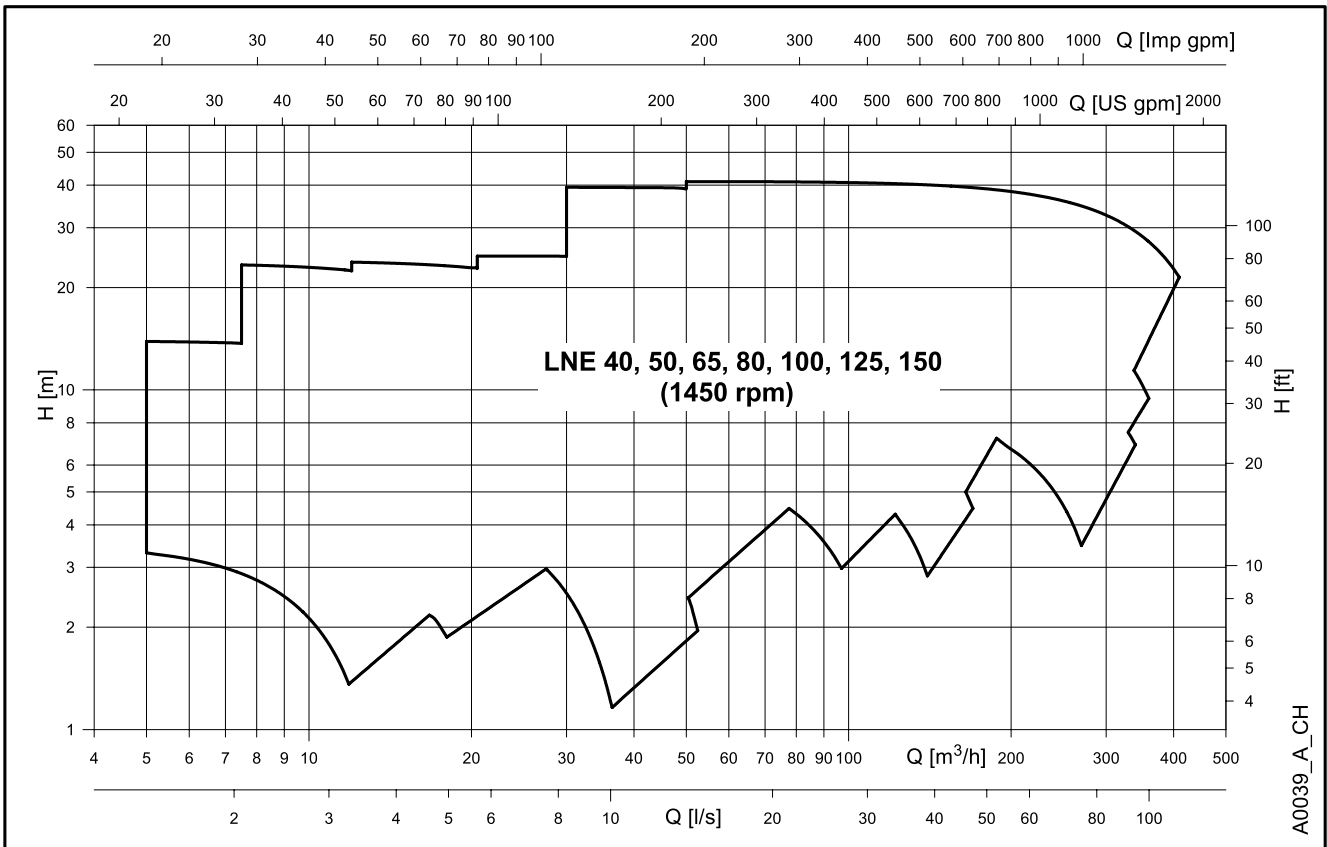

e-LNE SERIES GENERAL INTRODUCTION

The new **Lowara e-LNE Series** is the result of the close collaboration between our customers and us; the new range has been redesigned and improved to meet the Commercial Building Services (CBS) requirements, in terms of performances and energy saving.

In addition the new **Lowara e-LNE Series** can be customized to meet the needs of the Industry, keeping the best-in-class quality in production that affords our pumps continuous reliability and robustness in operation.

Pump design

The new **Lowara e-LNE Series** is a single-impeller centrifugal pump with in-line suction and delivery flanges. The e-LNE Series has a "Back pull-out" design (impeller, adapter, and motor can be extracted without disconnecting the pump body from the piping system).

The pumps have cast iron casing as standard; the impeller standard material is cast iron but is also available in bronze and stainless steel.

The pumps are equipped with interchangeable mechanical seals and IE3 efficiency motors; and are available in the following constructions:

Extended shaft

Close-coupled by means of an adaptor bracket with an impeller keyed directly to the special motor shaft extension.



Stub shaft

Rigid-coupled with a bracket, an adaptor and a rigid coupling keyed to the standard motor shaft extension.



Hydraulic specifications

- Maximum delivery: **410** m³/h (4-pole range).
- Maximum head: **41** m (4-pole range).
- Hydraulic performance compliant with ISO 9906:2012 – Grade 3B.
Grade 2B and 1B available upon request.
- Fluid temperature range:
 - standard version (with mechanical seal BQ1EGG-WA and EPDM gasket) **-25 to +120 °C**
 - versions on request (depending on mechanical seal and gasket) **-20* or -25 to +120 or +140 °C**.
- Maximum operating pressure:
 - standard version (with mechanical seal BQ1EGG-WA) **16 bar @ 90 °C** and **10 bar @ 120 °C**
 - versions on request (with other mechanical seals) **16 bar @ 120 °C** and **14,9 bar @ 140 °C**

* Fluoro-elastomer: FPM (old ISO), FKM (ASTM & new ISO).

Motor specifications

- Squirrel cage in short circuit enclosed construction with external ventilation (TEFC).
- 4-pole range.
- **IP55** protection degree as motor (EN 60034-5), IPX5 as electro-pump (EN 60529).
- Performances according to EN 60034-1.
- **IE3** efficiency level (three-phase 0,75 to 375 kW).
- **155 (F)** insulation class.
- Standard voltage:
 - 3 x 220-240/380-415 V 50 Hz for power up to 3 kW.
 - 3 x 380-415/660-690 V 50 Hz for power above 3 kW.
- Maximum ambient temperature: 40 °C.

Note

- Anti-clockwise rotation when facing pump's suction port.
- Pump does not include counter-flanges.

List of the Directives

- Machinery Directive MD 2006/42/EC
- Electromagnetic Compatibility Directive EMCD 2004/108/EC
- Ecodesign requirements for energy-related products ErP 2009/125/EC Regulation (EC) No 640/2009, Regulation (EU) No 4/2014, Regulation (EU) No 547/2012

and the main technical norms

- EN 809, EN 60204-1 (safety)
- EN 1092-2 (cast iron flanges)
- EN 61000-6-1, EN 61000-6-3
- EN 60034-30:2009, IEC 60034-30-1:2014 (electric motors)

e-LNE SERIES COMMERCIAL BUILDING SERVICES (CBS) APPLICATIONS & BENEFITS

Applications

The **Lowara e-LNE** Series is suitable for many different applications demanding variable duty points, reliable, and efficient products in cost saving operation.

The Lowara e-LNE Series can be used for the following CBS applications:

- **HVAC**
 - Liquid transfer in heating systems.
 - Liquid transfer in air-conditioning systems.
 - Liquid transfer in ventilation systems.
- **Water Supply**
 - Pressure boosting in commercial buildings.
 - Irrigation systems.
 - Water transfer for green houses.



Benefits

The Lowara e-LNE Series permit to achieve the following benefits.

- **Performances:** the e-LNE pumps are ErP 2015 compliant, equipped with IE3 motors, and with hydraulic target points and coverage that satisfy the needs of CBS applications. The standard full cast iron version with PN16, 120 °C maximum fluid temperature, and EPDM elastomer is exactly what the CBS Market needs.
- **Reliability:** robust construction and high-quality standards in production, interchangeable mechanical seals and wear rings, guarantee a continuous operation without faults and a shorter down time for maintenance.
- **Versatility:** beside the standard offer, the Lowara e-LNE series is available in different construction as well as with different material configurations for impellers and elastomers. That helps in addressing a wide range of applications.
- **Total cost ownership:** the best-in-class hydraulic and electric efficiency, the HYDROVAR-equipped versions, the easy and quick maintenance, allow to reduce the operation and maintenance cost and to save energy when the pump is working or is at rest.
- **Pre-post sales support:** we are continuously working close to our customers to help them in selecting the right pump for the specific application. A user-friendly selection software is available on the website, on DVD, or on Apps for mobile phones. Experienced engineers are fully dedicated to big projects.



e-LNE SERIES RATING PLATE

ELECTRIC PUMP

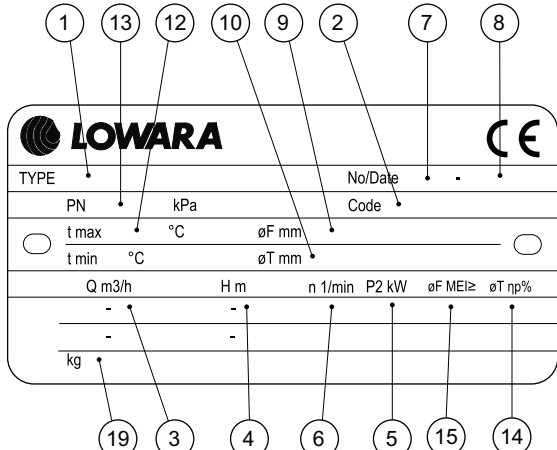

LOWARA		CE	
TYPE	No/Date		
PN	kPa	Code	
t max °C	øF mm		
t min °C	øT mm		
Q m ³ /h	H m	n 1/min	P ₂ kW
			øF MEI≥
			øT ηp%
kg			

LEGEND

- 1 - Electric pump unit type
- 2 - Electric pump unit code
- 3 - Flow range
- 4 - Head range
- 5 - Nominal or maximum pump power
- 6 - Speed
- 7 - Serial number or order number
- 8 - Date
- 9 - Full impeller diameter
- 10 - Trimmed impeller diameter (only filled-in for models with trimmed impellers)
- 12 - Maximum operating liquid temperature
- 13 - Maximum operating pressure
- 14 - Hydraulic efficiency in best efficiency point [Regulation (EU) No 547/2012]
- 15 - Minimum efficiency index MEI for corresponding full impeller diameter [Regulation (EU) No 547/2012]
- 19 - Weight

e-LNE SERIES
LIST OF MODELS AT 50 Hz, 2 POLES

SIZE LNE..2	kW	VERSION	
		LNEE	LNES
40-125/11(*)	1,1	•	•
40-125/15(*)	1,5	•	•
40-125/22(*)	2,2	•	•
40-125/30	3	•	•
40-160/30	3	•	•
40-160/40	4	•	•
40-160/55	5,5	•	•
40-200/40	4	•	•
40-200/55	5,5	•	•
40-200/75	7,5	•	•
40-250/92	9,2	•	-
40-250/110A	11	-	•
40-250/110	11	•	•
40-250/150	15	•	•
50-125/15(*)	1,5	•	•
50-125/22(*)	2,2	•	•
50-125/30	3	•	•
50-125/40	4	•	•
50-160/40	4	•	•
50-160/55	5,5	•	•
50-160/75	7,5	•	•
50-200/75	7,5	•	•
50-200/92	9,2	•	-
50-200/110A	11	-	•
50-200/110	11	•	•
50-250/110	11	•	•
50-250/150	15	•	•
50-250/185	18,5	•	•
50-250/220	22	•	•
65-125/30	3	•	•
65-125/40	4	•	•
65-125/55	5,5	•	•
65-125/75	7,5	•	•
65-160/75	7,5	•	•
65-160/92	9,2	•	-
65-160/110A	11	-	•
65-160/110	11	•	•
65-200/110	11	•	•
65-200/150	15	•	•
65-200/185	18,5	•	•
65-250/185	18,5	•	•
65-250/220	22	•	•
65-250/300	30	-	•

• = Available

LNE_models-2p50-en_a_sc

SIZE LNE..2	kW	VERSION	
		LNEE	LNES
80-160/75	7,5	•	•
80-160/92	9,2	•	-
80-160/110A	11	-	•
80-160/110	11	•	•
80-160/150	15	•	•
80-160/185	18,5	•	•
80-200/185	18,5	-	•
80-200/220	22	-	•
80-200/300	30	-	•
80-250/370	37	-	•
100-160/110	11	•	•
100-160/150	15	•	•
100-160/185	18,5	•	•
100-160/220	22	•	•
100-200/220	22	-	•
100-200/300	30	-	•
100-200/370	37	-	•
100-250/370	37	-	•

(*) Models available also in single-phase version.

LEGEND

LNEE : Extended shaft (single version).

LNES : Stub shaft (single version).

e-LNE SERIES
LIST OF MODELS AT 50 Hz, 4 POLES

SIZE LNE..4	kW	VERSION	
		LNEE	LNES
40-125/02B	0,25	•	-
40-125/02A	0,25	•	-
40-125/02	0,25	•	-
40-125/03	0,37	•	-
40-160/03	0,37	•	-
40-160/05	0,55	•	•
40-160/07	0,75	•	•
40-200/05	0,55	•	•
40-200/07	0,75	•	•
40-200/11	1,1	•	•
40-250/11	1,1	-	•
40-250/15A	1,5	•	-
40-250/15	1,5	•	•
40-250/22	2,2	•	•
50-125/02A	0,25	•	-
50-125/02	0,25	•	-
50-125/03	0,37	•	-
50-125/05	0,55	•	•
50-160/05	0,55	•	•
50-160/07	0,75	•	•
50-160/11	1,1	•	•
50-200/11A	1,1	•	•
50-200/11	1,1	•	•
50-200/15	1,5	•	•
50-250/15	1,5	•	•
50-250/22A	2,2	•	•
50-250/22	2,2	•	•
50-250/30	3	•	•
65-125/03	0,37	•	-
65-125/05	0,55	•	•
65-125/07	0,75	•	•
65-125/11	1,1	•	•
65-160/11A	1,1	•	•
65-160/11	1,1	•	•
65-160/15	1,5	•	•
65-200/15	1,5	•	•
65-200/22A	2,2	•	•
65-200/22	2,2	•	•
65-250/22	2,2	•	•
65-250/30	3	•	•
65-250/40	4	•	•

SIZE LNE..4	kW	VERSION	
		LNEE	LNES
80-160/11A	1,1	-	•
80-160/15B	1,5	•	-
80-160/11	1,1	-	•
80-160/15A	1,5	•	-
80-160/15	1,5	•	•
80-160/22A	2,2	•	•
80-160/22	2,2	•	•
80-200/22	2,2	-	•
80-200/30	3	-	•
80-200/40	4	-	•
80-250/55A	5,5	-	•
80-250/55	5,5	-	•
80-250/75	7,5	-	•
100-160/15	1,5	•	•
100-160/22A	2,2	•	•
100-160/22	2,2	•	•
100-160/30	3	•	•
100-200/30	3	-	•
100-200/40	4	-	•
100-200/55A	5,5	-	•
100-200/55	5,5	-	•
100-250/55A	5,5	-	•
100-250/55	5,5	-	•
100-250/75	7,5	-	•
100-250/110	11	-	•
125-160/22	2,2	-	•
125-160/30	3	-	•
125-160/40	4	-	•
125-200/55	5,5	-	•
125-200/75	7,5	-	•
125-250/75	7,5	-	•
125-250/110	11	-	•
125-315/150	15	-	•
125-315/185	18,5	-	•
125-315/220	22	-	•
125-315/300	30	-	•
150-200/55	5,5	-	•
150-200/75	7,5	-	•
150-200/110	11	-	•
150-250/110	11	-	•
150-250/150	15	-	•
150-315/185	18,5	-	•
150-315/220	22	-	•
150-315/300	30	-	•
150-315/370	37	-	•

• = Available

LNE_models-4p50-en_a_sc

LNEE SERIES ELECTRIC PUMP CROSS-SECTION AND MAIN COMPONENTS

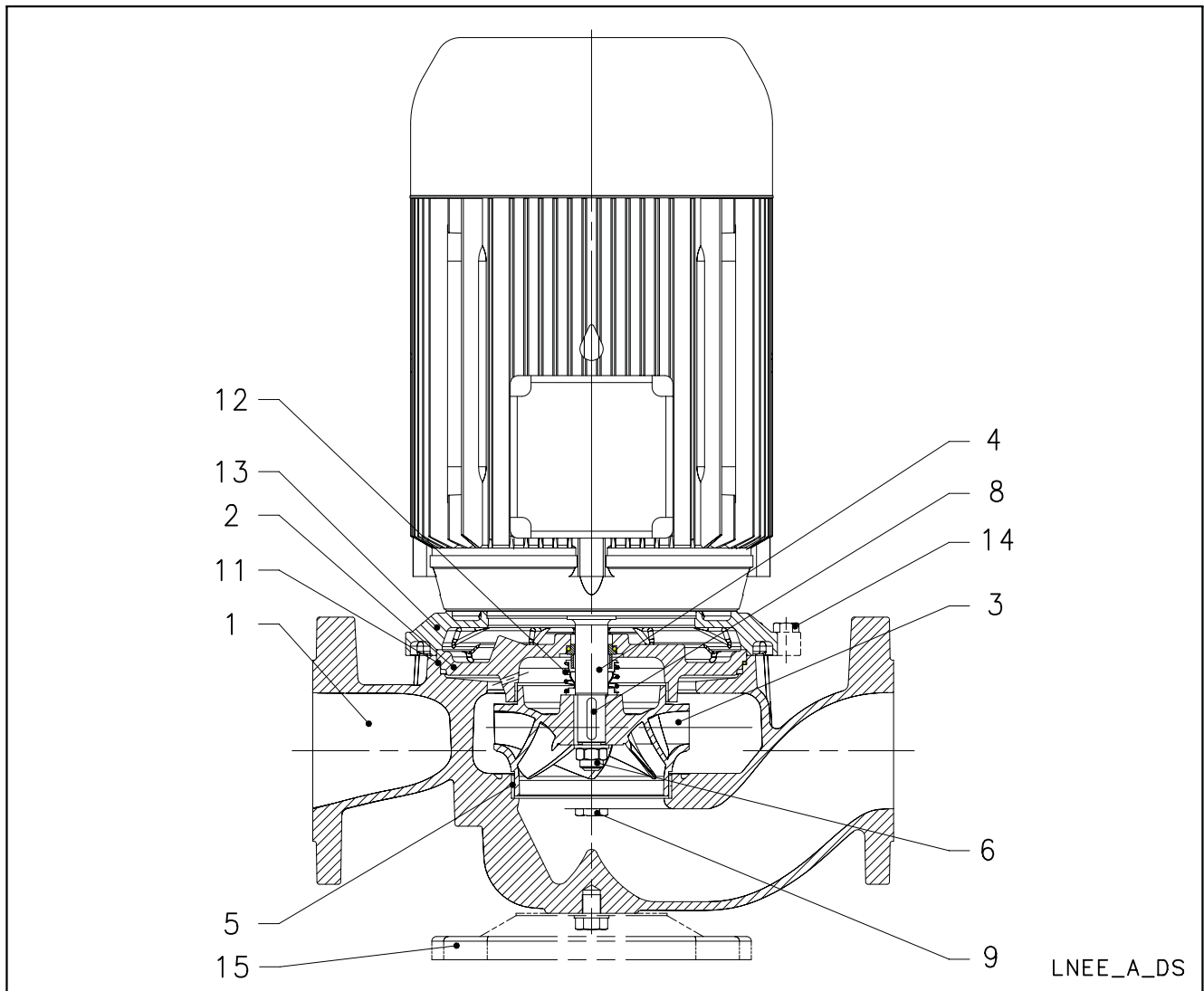

REF. N.	PART	MATERIAL	REFERENCE STANDARDS	
			EUROPE	USA
1	Volute casing	Cast iron	EN 1561 - GJL-250 (JL1040)	ASTM Class 35
2	Casing cover	Cast iron	EN 1561 - GJL-250 (JL1040)	ASTM Class 35
3	Impeller (40, 50, 65)	Stainless steel	EN 10088-1-X2CrNiMo17-12-2 (1.4404)	AISI 316L
	Impeller (80, 100)	Cast iron	EN 1561 - GJL-200 (JL1030)	ASTM Class 30
	Impeller (80, 100)	Bronze	EN 1982 - CuSn10-C (CC480K)	UNS C90700
4	Stub shaft	Stainless steel	EN 10088-1-X2CrNiMo17-12-2 (1.4404)	AISI 316L
5	Wear ring	Stainless steel	EN 10088 - X5CrNi18-10 (1.4301)	AISI 304
6	Impeller lock nut and washer	Stainless steel	EN 10088-1-X5CrNiMo17-12-2 (1.4401)	AISI 316
8	Impeller key	Stainless steel	EN 10088-1-X2CrNiMo17-12-2 (1.4404)	AISI 316L
9	Fill and drain plugs	Nickel-plated brass	EN 12164-CuZn39Pb3 (CW614N)	-
11	O-Ring	EPDM (standard version)		
12	Mechanical seal	Carbon / Silicon carbide / EPDM (standard version)		
13	Motor adapter *	Aluminium	EN 1706-AC-AISI11Cu2 (Fe) (AC46100)	-
	Motor adapter	Cast iron	EN 1561 - GJL-250 (JL1040)	ASTM Class 35
14	Volute casing fastening bolts and screws	Carbon steel		
15	Pump base (optional)	Carbon steel	EN 10025-2 - 1.0038	

* 2/4 pole: 40/50/65-125, 40/50-160

LNES SERIES

ELECTRIC PUMP CROSS-SECTION AND MAIN COMPONENTS

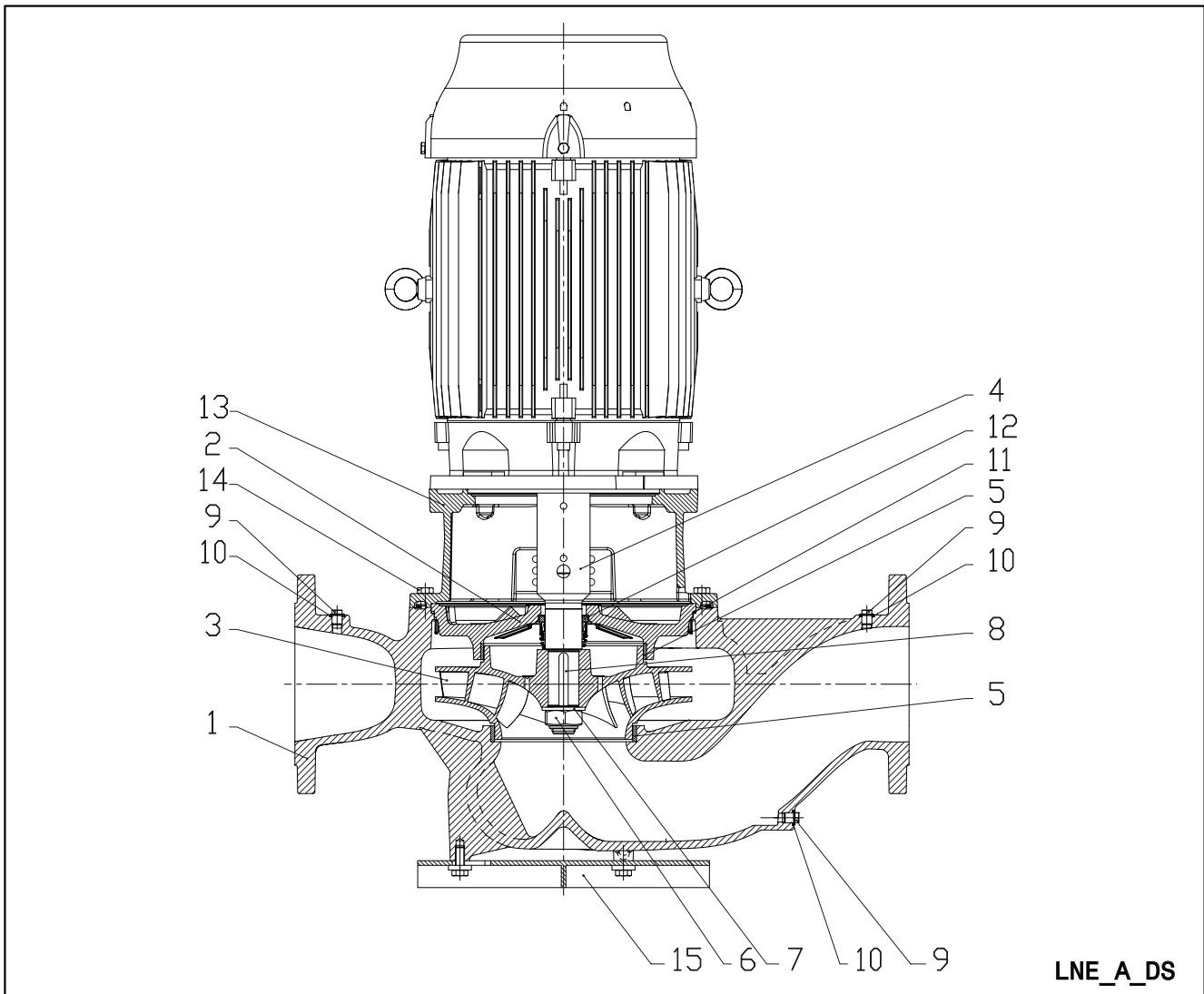

REF. N.	PART	MATERIAL	REFERENCE STANDARDS	
			EUROPE	USA
1	Volute casing	Cast iron	EN 1561 - GJL-250 (JL1040)	ASTM Class 35
2	Casing cover	Cast iron	EN 1561 - GJL-250 (JL1040)	ASTM Class 35
3	Impeller	Cast iron	EN 1561 - GJL-200 (JL1030)	ASTM Class 30
	Impeller	Bronze	EN 1982 - CuSn10-C (CC480K)	UNS C90700
4	Stub shaft	Stainless steel	EN 10088 - X17CrNi16-2 (1.4057)	AISI 431
5	Wear ring	Stainless steel	EN 10088 - X5CrNi18-10 (1.4301)	AISI 304
6	Impeller nut	Stainless steel	A4 (~ 1.4401)	
7	Impeller washer	Stainless steel	A4 (~ 1.4401)	
8	Impeller key	Stainless steel	EN 10088 - X6CrNiMo17-12-2 (1.4571)	AISI 316Ti
9	Plug	Stainless steel	EN 10088 - X6CrNiMo17-12-2 (1.4571)	AISI 316Ti
10	Gasket	Asbestos-free synthetic fiber AFM 34		
11	O-Ring	EPDM (standard version)		
12	Mechanical seal	Carbon / Silicon carbide / EPDM (standard version)		
13	Motor adapter	Cast iron	EN 1561 - GJL-250 (JL1040)	ASTM Class 35
14	Volute - casing fastening screws	Carbon steel		
15	Pump base (optional)	Carbon steel	EN 10025-2 - 1.0038	

e-LNE SERIES MECHANICAL SEALS

Mechanical seal with mounting dimensions according to EN 12756 and ISO 3069.

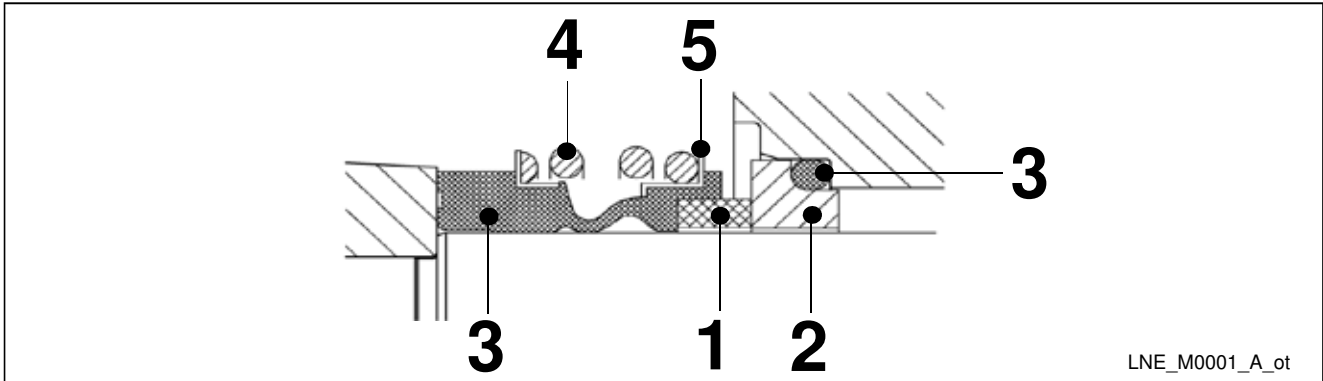

LIST OF MATERIALS

POSITION 1 - 2	POSITION 3	POSITION 4 - 5
B : Resin impregnated carbon	E : EPDM	G : AISI 316
A : Antimony impregnated carbon	V : FKM (FPM)	
Q₁ : Silicon carbide		
U₃ : Tungsten carbide		

TYPE OF SEAL

lne-int_tpi-ten-mec-en_a_tm

TYPE	POSITION					PRESSURE (bar)	TEMPERATURE (°C)
	1 ROTATING ASSEMBLY	2 FIXED ASSEMBLY	3 ELASTOMERS	4 SPRINGS	5 OTHER COMPONENTS		
STANDARD MECHANICAL SEAL							
B Q ₁ E G G - WA	B	Q ₁	E	G	G	16/10	-25 ... +90/+120
OTHER TYPES OF MECHANICAL SEAL							
B Q ₁ V G G	B	Q ₁	V	G	G	16	-20 ... +120 *)
Q ₁ Q ₁ E G G	Q ₁	Q ₁	E	G	G	16	-25 ... +120
Q ₁ Q ₁ V G G	Q ₁	Q ₁	V	G	G	16	-20 ... +120 *)
U ₃ A E G G	U ₃	A	E	G	G	16	-25 ... +140
U ₃ A V G G	U ₃	A	V	G	G	16	-20 ... +140 *)

*) for hot water: max. +90 °C

lne-int_tpi-ten-mec-en_b_tc

PRESSURE/TEMPERATURE APPLICATION LIMITS FOR COMPLETE PUMP

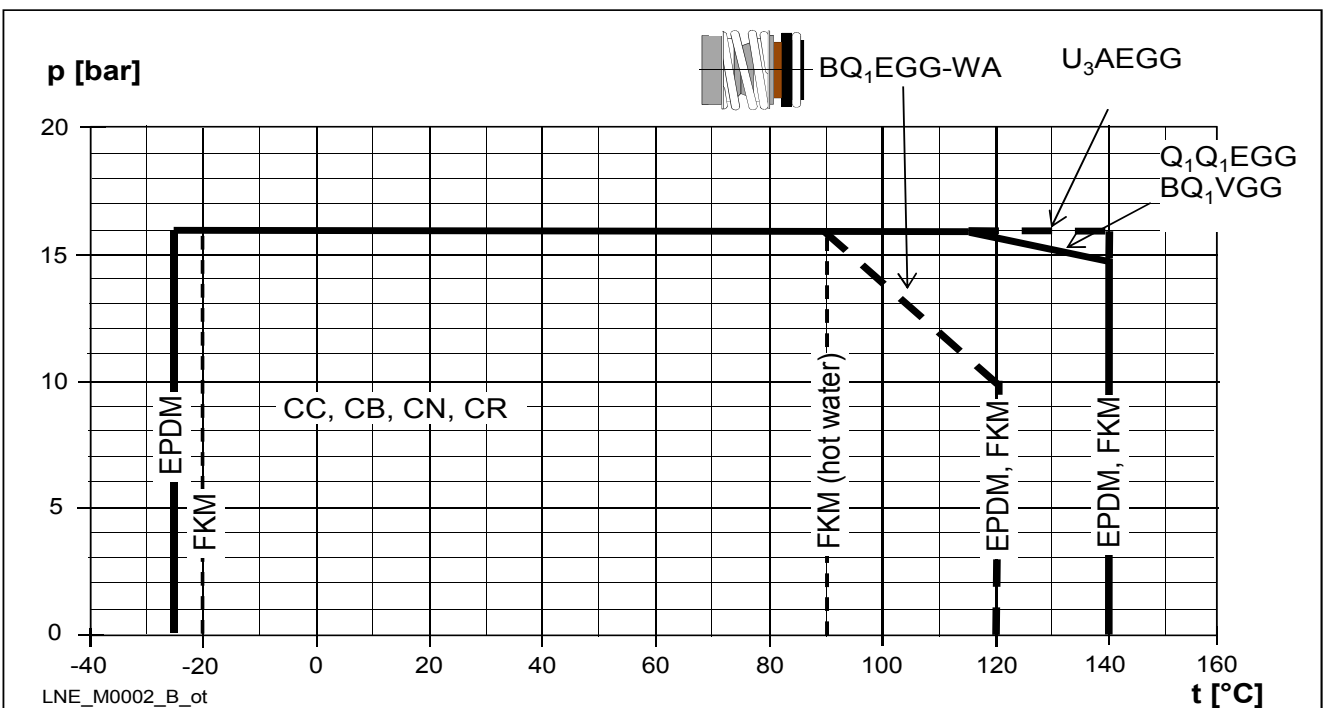

**e-LNE SERIES
MOTORS**

With the “Energy using Products” (EuP 2005/32/EC) and “Energy related Products” (ErP 2009/125/EC) directives, the European Commission has established requirements for promoting the use of products with low power consumption.

The various products considered include **three-phase 50 Hz surface motors with power outputs ranging from 0,75 to 375 kW**, also when integrated with other products, with characteristics as defined by the specific **Regulation (EC) No 640/2009** implementing the requirements of the EuP and ErP Directives which also establish the following deadlines:

from	kW	minimum level of efficiency (IE)
16 th June 2011	0,75 ÷ 375	IE2
27 th July 2014	0,75 ÷ 375	new exclusion criteria ¹⁾
1 st January 2015	< 7,5	IE2
	7,5 ÷ 375	IE3
		IE2 fitted with variable speed drive ²⁾
1 st January 2017	0,75 ÷ 375	IE3
		IE2 fitted with variable speed drive ²⁾

¹⁾ Fixed by subsequent **Regulation (EU) No 4/2014**.

²⁾ IE 2 motor can be supplied without frequency converter as the obligation to have that device is related to when motor works and not when is placed on the market.

- Short-circuit squirrel-cage motor, enclosed construction with external ventilation (TEFC).
- Rated power from 1,1 to 37 kW for 2-pole range and from 0,25 to 37 kW for 4-pole range.
- **IP55** protection degree.
- Insulation class **155 (F)**.
- **Standard** three-phase surface motors $\geq 0,75$ kW supplied as **IE3**.
- IE efficiency level according to EN 60034-30:2009 and IEC 60034-30-1:2014 ($\geq 0,75$ kW).
- Electrical performances according to EN 60034-1.
- Metric cable gland according to EN 50262.
- **Single-phase** version:
220-240 V 50 Hz
Built-in automatic reset overload protection up to 1,5 kW. For higher powers the protection must be provided by the user.
- **Three-phase** version:
220-240/380-415 V 50 Hz for power up to 3 kW.
380-415/660-690 V 50 Hz for power above 3 kW.
Overload protection to be provided by the user.
- **PTC included** (one per phase, 155°C).
- Maximum ambient temperature: 40 °C.

**LNEE SERIES
SINGLE-PHASE MOTORS AT 50 Hz, 2 POLES**

P _N kW	MOTOR TYPE	IEC SIZE*	Construction Design	INPUT CURRENT I _n (A) 220-240 V	CAPACITOR		DATA FOR 230 V 50 Hz VOLTAGE						
					µF	V	min ⁻¹	I _s / I _n	η %	cosφ	T _n Nm	T _s /T _n	T _m /T _n
1,1	SM90RB14S2/1115	90R	B14	6,88-6,65	30	450	2800	3,89	74,7	0,96	3,75	0,46	1,72
1,5	SM90RB14S2/1155	90R	B14	9,21-8,58	40	450	2810	4,00	76,1	0,98	5,15	0,39	1,74
2,2	PLM90B14S2/1225	90	B14	12,5-11,6	70	450	2825	4,47	82,4	0,97	7,43	0,53	1,87

* R = Reduced size of motor casing as compared to shaft extension and flange.

LNEE-motm-2p50-en_a_te

LNEE SERIES THREE-PHASE MOTORS AT 50 Hz, 2 POLES

P _N kW	Efficiency η_N															IE	Year of manufacture	
	%																	
	Δ 220 V Y 380 V			Δ 230 V Y 400 V			Δ 240 V Y 415 V			Δ 380 V Y 660 V			Δ 400 V Y 690 V					Δ 415 V
	4/4	3/4	2/4	4/4	3/4	2/4	4/4	3/4	2/4	4/4	3/4	2/4	4/4	3/4	2/4	4/4	3/4	2/4
1,1	84,0	84,7	83,4	84,4	84,5	82,5	84,3	84,0	81,4	84,0	84,0	81,4	84,0	84,0	81,4	84,0	84,0	81,4
1,5	85,6	86,5	85,8	85,9	86,4	84,9	86,0	86,0	84,0	85,6	86,0	84,0	85,6	86,0	84,0	85,6	86,0	84,0
2,2	86,5	87,4	86,8	86,4	86,9	85,7	86,6	86,7	85,0	86,4	86,7	85,0	86,4	86,7	85,0	86,4	86,7	85,0
3	87,2	88,5	88,3	87,5	88,2	87,5	87,5	87,8	86,4	87,2	87,8	86,4	87,2	87,8	86,4	87,2	87,8	86,4
4	89,1	90,1	89,2	89,1	90,1	89,2	89,1	90,1	89,2	89,1	90,3	90,4	89,6	90,4	89,9	89,6	90,1	89,2
5,5	89,5	89,6	88,0	89,5	89,6	88,0	89,5	89,6	88,0	89,5	90,3	89,9	89,7	90,0	89,0	89,6	89,6	88,0
7,5	90,6	90,5	89,0	90,6	90,5	89,0	90,6	90,5	89,0	90,6	91,0	90,2	90,8	90,8	89,6	90,7	90,5	89,0
9,2	90,8	91,0	89,7	90,8	91,0	89,7	90,8	91,0	89,7	90,8	91,4	90,8	91,1	91,3	90,3	91,1	91,0	89,7
11	91,3	92,0	91,1	91,3	92,0	91,1	91,3	92,0	91,1	91,3	92,2	92,2	91,6	92,2	91,7	91,7	92,0	91,1
15	92,5	92,4	91,2	92,5	92,4	91,2	92,5	92,4	91,2	92,7	93,3	92,9	93,1	93,3	92,7	92,5	92,4	91,2
18,5	92,6	93,1	92,4	92,6	93,1	92,4	92,6	93,1	92,4	92,6	93,2	93,0	92,9	93,3	92,8	92,9	93,1	92,4
22	93,0	92,7	91,3	93,0	92,7	91,3	93,0	92,7	91,3	93,0	93,2	92,4	93,1	93,0	91,9	93,0	92,7	91,3

P _N kW	Manufacturer		IEC SIZE*	Construction Design	N. of Poles	f _N Hz	Data for 400 V / 50 Hz Voltage				
	Xylem Service Italia Srl Reg. No. 07520560967 Montecchio Maggiore Vicenza - Italia						cos ϕ	I _s / I _N	T _N Nm	T _s /T _N	T _m /T _N
	Model										
1,1	SM90RB14S2/311 PE		90R	SPECIAL	2	50	0,79	8,31	3,63	3,95	3,95
1,5	SM90RB14S2/315 PE		90R				0,80	8,80	4,96	4,31	4,10
2,2	PLM90B14S2/322 E3		90				0,80	8,77	7,28	3,72	3,70
3	PLM90B14S2/330 E3		90				0,79	7,81	9,93	4,26	3,94
4	PLM112RB14S2/340 E3		112R				0,85	9,13	13,2	3,82	4,32
5,5	PLM112B14S2/355 E3		112				0,85	10,5	18,1	4,74	5,11
7,5	PLM132B14S2/375 E3		132				0,85	10,2	24,4	3,43	4,76
	PLM132B14S3/375 E3		132								
9,2	PLM132B14S2/392 E3		132				0,85	10,1	30,0	3,73	4,81
	PLM132B14S3/392 E3		132								
11	PLM132B14S2/3110 E3		132				0,86	9,89	35,9	3,46	4,59
	PLM132B14S3/3110 E3		132								
15	PLM160B34S3/3150 E3		160	0,88	9,51	48,6	2,73	4,32			
18,5	PLM160B34S3/3185 E3		160	0,88	9,81	59,9	2,81	4,53			
22	PLM160B34S3/3220 E3		160	0,85	10,9	71,1	3,26	5,12			

P _N kW	Voltage U _N V											n _N min ⁻¹	Operating conditions **		
	Δ			Y			Δ			Y			Altitude Above Sea Level (m)	T. amb min/max °C	ATEX
	220 V	230 V	240 V	380 V	400 V	415 V	380 V	400 V	415 V	660 V	690 V				
1,1	4,19	4,14	4,16	2,42	2,39	2,40	2,41	2,38	2,38	1,39	1,37	2870 ÷ 2900	≤ 1000	-15 / 40	No
1,5	5,56	5,49	5,51	3,21	3,17	3,18	3,21	3,18	3,19	1,85	1,84	2870 ÷ 2895			
2,2	7,97	7,90	7,98	4,6	4,56	4,61	4,57	4,54	4,57	2,64	2,62	2880 ÷ 2900			
3	11,0	11,0	11,2	6,35	6,33	6,44	6,29	6,27	6,34	3,63	3,62	2865 ÷ 2895			
4	13,6	13,4	13,4	7,87	7,75	7,74	7,80	7,62	7,61	4,50	4,40	2885 ÷ 2910			
5,5	18,1	17,9	18,1	10,4	10,4	10,4	10,6	10,5	10,7	6,10	6,05	2880 ÷ 2910			
7,5	24,8	24,4	24,3	14,3	14,1	14,0	14,4	14,1	14,2	8,32	8,16	2920 ÷ 2935			
9,2	30,6	30,1	30,2	17,6	17,4	17,5	17,5	17,2	17,3	10,1	9,93	2920 ÷ 2935			
11	35,7	35,0	34,9	20,6	20,2	20,2	20,6	20,2	20,2	11,9	11,7	2910 ÷ 2930			
15	47,6	46,1	45,2	27,5	26,6	26,1	27,5	26,6	26,1	15,9	15,3	2940 ÷ 2950			
18,5	58,3	56,7	55,6	33,7	32,7	32,1	34,0	33,0	32,7	19,6	19,0	2940 ÷ 2950			
22	72,9	73,1	73,7	42,1	42,2	42,6	40,9	40,4	40,6	23,6	23,3	2950 ÷ 2960			

* R = Reduced size of motor casing as compared to shaft extension and flange.

LNEE-IE3-mott-2p50-en_a_te

** Operating conditions to be referred to motor only. About electric pump, refer to limits in user's manual.

LNES SERIES THREE-PHASE MOTORS AT 50 Hz, 2 POLES

P _N kW	Efficiency η_N %																		IE	Year of manufacture
	Δ 220 V Y 380 V			Δ 230 V Y 400 V			Δ 240 V Y 415 V			Δ 380 V Y 660 V			Δ 400 V Y 690 V			Δ 415 V				
	4/4	3/4	2/4	4/4	3/4	2/4	4/4	3/4	2/4	4/4	3/4	2/4	4/4	3/4	2/4	4/4	3/4	2/4		
1,1	84,0	84,7	83,4	84,4	84,5	82,5	84,3	84,0	81,4	84,0	84,0	81,4	84,0	84,0	81,4	84,0	84,0	81,4	3	From 11/2014
1,5	85,6	86,5	85,8	85,9	86,4	84,9	86,0	86,0	84,0	85,6	86,0	84,0	85,6	86,0	84,0	85,6	86,0	84,0		
2,2	86,5	87,4	86,8	86,4	86,9	85,7	86,6	86,7	85,0	86,4	86,7	85,0	86,4	86,7	85,0	86,4	86,7	85,0		
3	87,2	88,5	88,3	87,5	88,2	87,5	87,5	87,8	86,4	87,2	87,8	86,4	87,2	87,8	86,4	87,2	87,8	86,4		
4	89,1	90,1	89,2	89,1	90,1	89,2	89,1	90,1	89,2	89,1	90,3	90,4	89,6	90,4	89,9	89,6	90,1	89,2		
5,5	89,5	89,6	88,0	89,5	89,6	88,0	89,5	89,6	88,0	89,5	90,3	89,9	89,7	90,0	89,0	89,6	89,6	88,0		
7,5	90,6	90,5	89,0	90,6	90,5	89,0	90,6	90,5	89,0	90,6	91,0	90,2	90,8	90,8	89,6	90,7	90,5	89,0		
11	91,3	92,0	91,1	91,3	92,0	91,1	91,3	92,0	91,1	91,3	92,2	92,2	91,6	92,2	91,7	91,7	92,0	91,1		
15	92,5	92,4	91,2	92,5	92,4	91,2	92,5	92,4	91,2	92,7	93,3	92,9	93,1	93,3	92,7	92,5	92,4	91,2		
18,5	92,6	93,1	92,4	92,6	93,1	92,4	92,6	93,1	92,4	92,6	93,2	93,0	92,9	93,3	92,8	92,9	93,1	92,4		
22	93,0	92,7	91,3	93,0	92,7	91,3	93,0	92,7	91,3	93,0	93,2	92,4	93,1	93,0	91,9	93,0	92,7	91,3		

P _N kW	Manufacturer		IEC SIZE*	Construction Design	N. of Poles	f _N Hz	Data for 400 V / 50 Hz Voltage				
	Xylem Service Italia Srl Reg. No. 07520560967 Montecchio Maggiore Vicenza - Italia						cos ϕ	I _s / I _N	T _N Nm	T _s /T _N	T _m /T _N
	Model										
1,1	SM80B5/311 PE		80	B5	2	50	0,79	8,31	3,63	3,95	3,95
1,5	SM90RB5/315 PE		90R				0,80	8,80	4,96	4,31	4,10
2,2	PLM90B5/322 E3		90				0,80	8,77	7,28	3,72	3,70
3	PLM100RB5/330 E3		100R				0,79	7,81	9,93	4,26	3,94
4	PLM112RB5/340 E3		112R				0,85	9,13	13,2	3,82	4,32
5,5	PLM132RB5/355 E3		132R				0,85	10,5	18,1	4,74	5,11
7,5	PLM132B5/375 E3		132				0,85	10,2	24,4	3,43	4,76
11	PLM160RB5/3110 E3		160R				0,86	9,89	35,9	3,46	4,59
15	PLM160B5/3150 E3		160				0,88	9,51	48,6	2,73	4,32
18,5	PLM160B5/3185 E3		160				0,88	9,81	59,9	2,81	4,53
22	PLM180RB5/3220 E3		180R				0,85	10,9	71,1	3,26	5,12

P _N kW	Voltage U _N V										n _N min ⁻¹	Observe the regulations and codes locally in force regarding sorted waste disposal.	Operating conditions **			
	Δ			Y			Δ			Y			Altitude Above Sea Level (m)	T. amb min/max °C	ATEX	
	220 V	230 V	240 V	380 V	400 V	415 V	380 V	400 V	415 V	660 V						690 V
1,1	4,19	4,14	4,16	2,42	2,39	2,40	2,41	2,38	2,38	1,39	1,37	2870 ÷ 2900	≤ 1000	-15 / 40	No	
1,5	5,56	5,49	5,51	3,21	3,17	3,18	3,21	3,18	3,19	1,85	1,84	2870 ÷ 2895				
2,2	7,97	7,90	7,98	4,6	4,56	4,61	4,57	4,54	4,57	2,64	2,62	2880 ÷ 2900				
3	11,0	11,0	11,2	6,35	6,33	6,44	6,29	6,27	6,34	3,63	3,62	2865 ÷ 2895				
4	13,6	13,4	13,4	7,87	7,75	7,74	7,80	7,62	7,61	4,50	4,40	2885 ÷ 2910				
5,5	18,1	17,9	18,1	10,4	10,4	10,4	10,6	10,5	10,7	6,10	6,05	2880 ÷ 2910				
7,5	24,8	24,4	24,3	14,3	14,1	14,0	14,4	14,1	14,2	8,32	8,16	2920 ÷ 2935				
11	35,7	35,0	34,9	20,6	20,2	20,2	20,6	20,2	20,2	11,9	11,7	2910 ÷ 2930				
15	47,6	46,1	45,2	27,5	26,6	26,1	27,5	26,6	26,1	15,9	15,3	2940 ÷ 2950				
18,5	58,3	56,7	55,6	33,7	32,7	32,1	34,0	33,0	32,7	19,6	19,0	2940 ÷ 2950				
22	72,9	73,1	73,7	42,1	42,2	42,6	40,9	40,4	40,6	23,6	23,3	2950 ÷ 2960				

* R = Reduced size of motor casing as compared to shaft extension and flange.

LNES-IE3-mott-2p50-en_a_te

** Operating conditions to be referred to motor only. About electric pump, refer to limits in user's manual.

LNEE SERIES THREE-PHASE MOTORS AT 50 Hz, 4 POLES

P _N kW	Efficiency η_N																		IE	Year of manufacture				
	%																							
	Δ 220 V Y 380 V			Δ 230 V Y 400 V			Δ 240 V Y 415 V			Δ 380 V Y 660 V			Δ 400 V Y 690 V			Δ 415 V								
4/4	3/4	2/4	4/4	3/4	2/4	4/4	3/4	2/4	4/4	3/4	2/4	4/4	3/4	2/4	4/4	3/4	2/4							
0,25	-	-	-	-	-	-	-	-	-	-	-	-	-	-	-	-	-	-	-	-	-	-	-	-
0,37	-	-	-	-	-	-	-	-	-	-	-	-	-	-	-	-	-	-	-	-	-	-	-	-
0,55	-	-	-	-	-	-	-	-	-	-	-	-	-	-	-	-	-	-	-	-	-	-	-	-
0,75	80,4	81,3	79,8	81,1	81,4	79,1	81,4	81,2	78,4	80,4	81,2	78,4	80,4	81,2	78,4	80,4	81,2	78,4	80,4	81,2	78,4	2	06/2011	
1,1	84,9	85,7	84,7	85,3	85,5	83,8	85,3	85,0	82,7	84,9	85,0	82,7	84,9	85,0	82,7	84,9	85,0	82,7	84,9	85,0	82,7	3	from 11/2014	
1,5	86,6	87,0	85,7	86,7	86,9	84,5	86,4	85,9	83,3	86,4	85,9	83,3	86,4	85,9	83,3	86,4	85,9	83,3	86,4	85,9	83,3			
2,2	87,6	88,6	88,3	88,2	88,8	87,9	88,5	88,7	87,4	87,6	88,6	87,4	87,6	88,6	87,4	87,6	88,6	87,4	87,6	88,6	87,4			
3	88,5	89,2	88,5	88,6	88,9	87,6	88,6	88,6	86,8	88,5	88,6	86,8	88,5	88,6	86,8	88,5	88,6	86,8	88,5	88,6	86,8			
4	88,6	89,1	87,9	88,6	89,1	87,9	88,6	89,1	87,9	88,6	89,2	88,9	88,6	89,2	88,4	88,8	89,1	87,9						

P _N kW	Manufacturer		IEC SIZE*	Construction Design	N. of Poles	f _N Hz	Data for 400 V / 50 Hz Voltage				
	Xylem Service Italia Srl Reg. No. 07520560967 Montecchio Maggiore Vicenza - Italia						cos ϕ	I _s / I _N	T _N Nm	T _s /T _N	T _m /T _N
	Model										
0,25	SM471B5/302		71	B5	4	50	0,59	3,58	1,71	3,16	2,63
0,37	SM471B5/304		71				0,60	3,39	2,57	3,40	2,47
0,55	SM490RB14S2/305		90R	SPECIAL	4	50	0,67	3,95	3,77	2,45	2,38
		SM490RB5S2/305					90R	0,67	3,95	3,77	2,45
0,75	LLM490RB14S2/307		90R				0,75	5,78	5,03	2,77	3,31
	LLM490RB5S2/307		90R				0,71	6,22	7,28	2,75	3,44
1,1	PLM490B5S2/311 E3		90				0,68	6,92	9,89	3,29	4,01
1,5	PLM490B5S3/315 E3		90				0,78	7,47	14,5	2,38	3,69
2,2	PLM4100B5S3/322 E3		100				0,74	7,75	19,7	2,48	4,21
3	PLM4100B5S3/330 E3		100				0,79	8,32	26,3	3,19	4,02
4	PLM4112B5S3/340 E3		112								

P _N kW	Voltage U _N V										n _N min ⁻¹	Operating conditions **				
	Δ			Y			Δ			Y			Altitude Above Sea Level (m)	T. amb min/max °C	ATEX	
	220 V	230 V	240 V	380 V	400 V	415 V	380 V	400 V	415 V	660 V		690 V				
0,25	1,68	1,71	1,77	0,97	0,99	1,02	-	-	-	-	-	1375 ÷ 1400	≤ 1000	-15 / 40	No	
0,37	2,46	2,53	2,62	1,42	1,46	1,51	-	-	-	-	-	1355 ÷ 1380				
0,55	2,98	3,03	3,1	1,72	1,75	1,79	-	-	-	-	-	1380 ÷ 1400				
0,75	3,08	3,03	3,01	1,78	1,75	1,74	1,78	1,75	1,74	1,03	1,01	1410 ÷ 1430				
	1,1	4,61	4,59	4,62	2,66	2,65	2,67	2,64	2,63	2,65	1,53	1,52				1435 ÷ 1445
1,5	6,34	6,41	6,41	3,66	3,70	3,70	3,65	3,68	3,69	2,11	2,13	1440 ÷ 1450				
2,2	8,19	8,04	7,97	4,73	4,64	4,60	4,70	4,62	4,56	2,71	2,67	1445 ÷ 1455				
3	11,5	11,5	11,5	6,66	6,62	6,67	6,63	6,59	6,63	3,83	3,81	1450 ÷ 1460				
4	14,8	14,6	14,5	8,52	8,40	8,36	8,40	8,23	8,19	4,85	4,75	1445 ÷ 1455				

Observe the regulations and codes locally in force regarding sorted waste disposal.

* R = Reduced size of motor casing as compared to shaft extension and flange.

LNEE-IE3-mott-4p50-en_a_te

** Operating conditions to be referred to motor only. About electric pump, refer to limits in user's manual.

LNES SERIES THREE-PHASE MOTORS AT 50 Hz, 4 POLES

P _N kW	Efficiency η_N %																		IE	Year of manufacture
	Δ 220 V Y 380 V			Δ 230 V Y 400 V			Δ 240 V Y 415 V			Δ 380 V Y 660 V			Δ 400 V Y 690 V			Δ 415 V				
	4/4	3/4	2/4	4/4	3/4	2/4	4/4	3/4	2/4	4/4	3/4	2/4	4/4	3/4	2/4	4/4	3/4	2/4		
2,2	86,7	87,1	87,2	87,0	87,0	86,5	87,2	86,8	85,7	86,7	78,1	87,2	87,0	87,0	86,5	87,2	86,8	85,7	3	By June 2011
3	87,7	88,0	87,7	88,0	88,0	87,0	88,1	87,7	86,3	87,7	88,0	87,7	88,0	88,0	87,0	88,1	87,7	86,3		
4	88,6	89,0	89,3	89,1	89,1	88,7	89,3	88,9	88,2	88,6	89,0	89,3	89,1	89,1	88,7	89,3	88,9	88,2		
5,5	90,3	90,7	90,4	90,7	90,7	90,0	90,8	90,7	89,6	90,3	90,7	90,4	90,7	90,7	90,0	90,8	90,7	89,6		
7,5	91,2	91,5	91,4	91,5	91,5	91,0	91,7	91,4	90,5	91,2	91,5	91,4	91,5	91,5	91,0	91,7	91,4	90,5		
11	91,7	91,7	91,3	92,2	91,8	91,0	92,3	91,7	90,7	91,7	91,7	91,3	92,2	91,8	91,0	92,3	91,7	90,7		
15	93,0	92,5	92,2	93,0	92,5	91,8	93,0	92,4	91,4	93,0	92,5	92,2	93,0	92,5	91,8	93,0	92,4	91,4		
18,5	93,1	92,9	92,5	93,3	92,9	92,2	93,4	92,8	91,8	93,1	92,9	92,5	93,3	92,9	92,2	93,4	92,8	91,8		
22	93,4	93,1	92,8	93,6	93,0	92,4	93,6	92,8	91,9	93,4	93,1	92,8	93,6	93,0	92,4	93,6	92,8	91,9		
30	94,1	94,1	93,5	94,2	94,0	93,0	94,2	93,9	92,5	94,1	94,1	93,5	94,2	94,0	93,0	94,2	93,9	92,5		
37	94,3	94,5	94,1	94,6	94,6	94,0	94,7	94,6	93,8	94,3	94,5	94,1	94,6	94,6	94,0	94,7	94,6	93,8		

P _N kW	Manufacturer		IEC SIZE	Construction Design	N. of Poles	f _N Hz	Data for 400 V / 50 Hz Voltage				
	WEG Equipamentos Eletricos S.A. Reg. No. 07.175.725/0010-50 Jaragua do Sul - SC (Brazil)						cos ϕ	I _s / I _N	T _N Nm	T _s /T _N	T _m /T _N
	Model										
2,2	W22 100L4A-B5 2,2kW E3		100	B5	4	50	0,80	7,40	14,60	3,20	3,50
3	W22 L100L4B-B5 3kW E3		100				0,80	7,80	19,90	3,50	3,70
4	W22 112M4-B5 4kW E3		112				0,79	7,00	26,30	2,30	3,10
5,5	W22 132S4-B5 5,5kW E3		132				0,85	8,50	35,85	2,40	3,40
7,5	W22 132M4-B5 7,5kW E3		132				0,84	8,50	48,90	2,50	3,40
11	W22 160M4-B5 11kW E3		160				0,83	7,00	71,45	2,50	3,00
15	W22 160L4-B5 15kW E3		160				0,82	7,30	97,40	2,70	3,20
18,5	W22 180M4-B5 18,5kW E3		180				0,82	7,30	120,20	2,70	3,00
22	W22 180L4-B5 22kW E3		180				0,83	7,30	142,90	2,80	3,30
30	W22 200L4-B5 30kW E3		200				0,82	7,30	193,60	2,50	3,00
37	W22 225S4-B5 37kW E3		225				0,86	7,80	238,70	2,70	3,00

P _N kW	Voltage U _N V										n _N min ⁻¹	Operating conditions **			
	Δ			Y			Δ			Y		Altitude Above Sea Level (m)	T. amb min/max °C	ATEX	
	220 V	230 V	240 V	380 V	400 V	415 V	380 V	400 V	415 V	660 V					690 V
2,2	8,05	7,93	7,78	4,66	4,56	4,50	4,66	4,56	4,50	2,68	2,64	1435	≤ 1000	-15 / +40	No
3	10,8	10,7	10,5	6,26	6,15	6,07	6,26	6,15	6,07	3,60	3,57	1440			
4	13,8	13,9	13,8	8,00	8,00	8,00	8,00	8,00	8,00	4,61	4,64	1450			
5,5	18,3	17,9	17,6	10,6	10,3	10,2	10,6	10,3	10,2	6,10	5,97	1465			
7,5	24,9	24,2	23,3	14,4	13,9	13,5	14,4	13,9	13,5	8,29	8,06	1465			
11	36,4	36,0	35,4	21,1	20,7	20,5	21,1	20,7	20,5	12,1	12,0	1470			
15	50,4	49,4	48,4	29,2	28,4	28,0	29,2	28,4	28,0	16,8	16,5	1470			
18,5	62,0	60,7	59,5	35,9	34,9	34,4	35,9	34,9	34,4	20,7	20,2	1470			
22	72,7	71,1	69,9	42,1	40,9	40,4	42,1	40,9	40,4	24,2	23,7	1470			
30	99,7	97,6	95,8	57,7	56,1	55,4	57,7	56,1	55,4	33,2	32,5	1480			
37	118	114	110	68,5	65,6	63,9	68,5	65,6	63,9	39,4	38,0	1480			

Observe the regulations and codes locally in force regarding sorted waste disposal.

** Operating conditions to be referred to motor only. About electric pump, refer to limits in user's manual.

Lnes-mott-4p50-en_a_te

MOTOR NOISE

The tables below show the mean sound pressure levels (Lp) measured at 1 meter's distance in a free field according to the A curve (ISO 1680 standard).

The noise values are measured with idling 50 Hz motor with a tolerance of 3 dB (A).

LNEE, LNES MOTORS 2 POLES 50 Hz

POWER	MOTOR TYPE	NOISE
kW	IEC SIZE *	LpA dB
1,1	80 - 90R	<70
1,5	90R	<70
2,2	90	<70
3	90 100R	<70
4	112R	<70
5,5	112 - 132R	<70
7,5	132	71
9,2	132	73
11	132 - 160R	73
15	160	71
18,5	160	73
22	160	70

*R=Reduced size of motor casing as compared to shaft extension and flange.

LNEE, LNES MOTORS 4 POLES 50 Hz

POWER	MOTOR TYPE	NOISE
kW	IEC SIZE *	LpA dB
0,25	71	<70
0,37	71	<70
0,55	90R	<70
0,75	90R	<70
1,1	90	<70
1,5	90	<70
2,2	100	<70
3	100	<70
4	112	<70
5,5	132	<70
7,5	132	<70
11	160	<70
15	160	<70
18,5	180	<70
22	180	<70
30	200	<70
37	225	<70

LNE_mott-en_a_tr

e-LNE SERIES PUMPS

Over last decade the European Commission with the 'Energy Efficiency Plan' pushed the European Parliament and the Council to adopt specific measures to the purpose of reducing energy consumption and further negative environmental impacts. Through the Directives 2005/32/EC, energy-using products (EuP), and 2009/125/EC, energy-related products (ErP) a framework for ecodesign requirements was established.

The **Commission Regulation (EU) No 547/2012** has implemented two directives with regard to ecodesign requirements for **some types of clean water pumps** placed on the market and put into service inside EU zone as self-alone units or integrated in other products.

For end-suction close-coupled in-line pumps (ESCCi for the Regulation) the efficiency assessment refers to:

- just the pump and not the pump and motor assembly (electric or combustion);
- pumps with just one impeller;
- pumps with a nominal pressure PN not higher than 16 bar (1600 kPa);
- pumps with a minimum nominal flow not less than 6 m³/h;
- pumps with a maximum nominal power at the shaft not higher than 150 kW;
- pumps designed to operate at a speed of 2900 min⁻¹ (for electric pumps this means 50 Hz 2-pole electric motors) and with a head not greater than 140 metres;
- pumps designed to operate at a speed of 1450 min⁻¹ (for electric pumps this means 50 Hz 4-pole electric motors) and with a head not greater than 90 metres;
- use with clean water at a temperature ranging from -10°C to 120°C (the test is performed with cold water at a temperature not higher than 40°C).

According to the definitions established in the Regulation LNEE and LNES versions correspond to the "end-suction close-coupled in-line pump".

This regulation states that water pumps shall have a minimum index MEI coming from a dedicated formula which considers hydraulic efficiency values at 'best efficiency point' (BEP), 75 % of the flow at BEP (Part load – PL) and 110 % of the flow at BEP (Over load – OL).

The Regulation also establishes the following deadlines.

from	minimum efficiency index (MEI)
1 st January 2013	MEI ≥ 0,1
1 st January 2015	MEI ≥ 0,4

Regulation (EU) n. 547/2012 – Annex II – point 2 (Product information requirements)

- 1) Minimum efficiency index: see MEI values in specific tables on following page.
- 2) "The benchmark for most efficient water pumps is MEI ≥ 0,70".
- 3) Year of manufacture: 2014.
- 4) Manufacturer: Xylem Service Italia Srl - Reg. No 07520560967 - Montecchio Maggiore, Vicenza, Italy.
- 5) Product type: see the PUMP TYPE column in the tables in the *Hydraulic performance* section.
- 6) Hydraulic pump efficiency with trimmed impeller: see η_p and $\varnothing T$ columns in the tables in the *Hydraulic performance* section.
- 7) Pump performance curves, including the performance curve: see the *Operating Characteristics* graphs in the following pages.
- 8) "The efficiency of a pump with a trimmed impeller is usually lower than that of a pump with the full impeller diameter. The trimming of the impeller will adapt the pump to a fixed duty point, leading to reduced energy consumption. The minimum efficiency index (MEI) is based on the full impeller diameter".
- 9) "The operation of this water pump with variable duty points may be more efficient and economic when controlled, for example, by the use of a variable speed drive that matches the pump duty to the system".
- 10) Information relevant for disassembly, recycling or disposal at end-of-life: observe the current laws and by-laws governing sorted waste disposal. Consult the product operating manual.
- 11) "Designed for use below – 10 °C only": note not applicable to these products.
- 12) "Designed for use above 120 °C only": note not applicable to these products.
- 13) Specific instructions for pumps as per points 11 and 12: not applicable to these products.
- 14) "Information on benchmark efficiency is available at": www.europump.org (Ecodesign section).
- 15) The benchmark efficiency graphs with MEI = 0.7 and MEI = 0.4 are available at www.europump.org/efficiencycharts or <http://europump.net/uploads/Fingerprints.pdf> (refer to "ESCCi 1450 rpm").

e-LNE SERIES

HYDRAULIC PERFORMANCE RANGE AT 50 Hz, 2 POLES

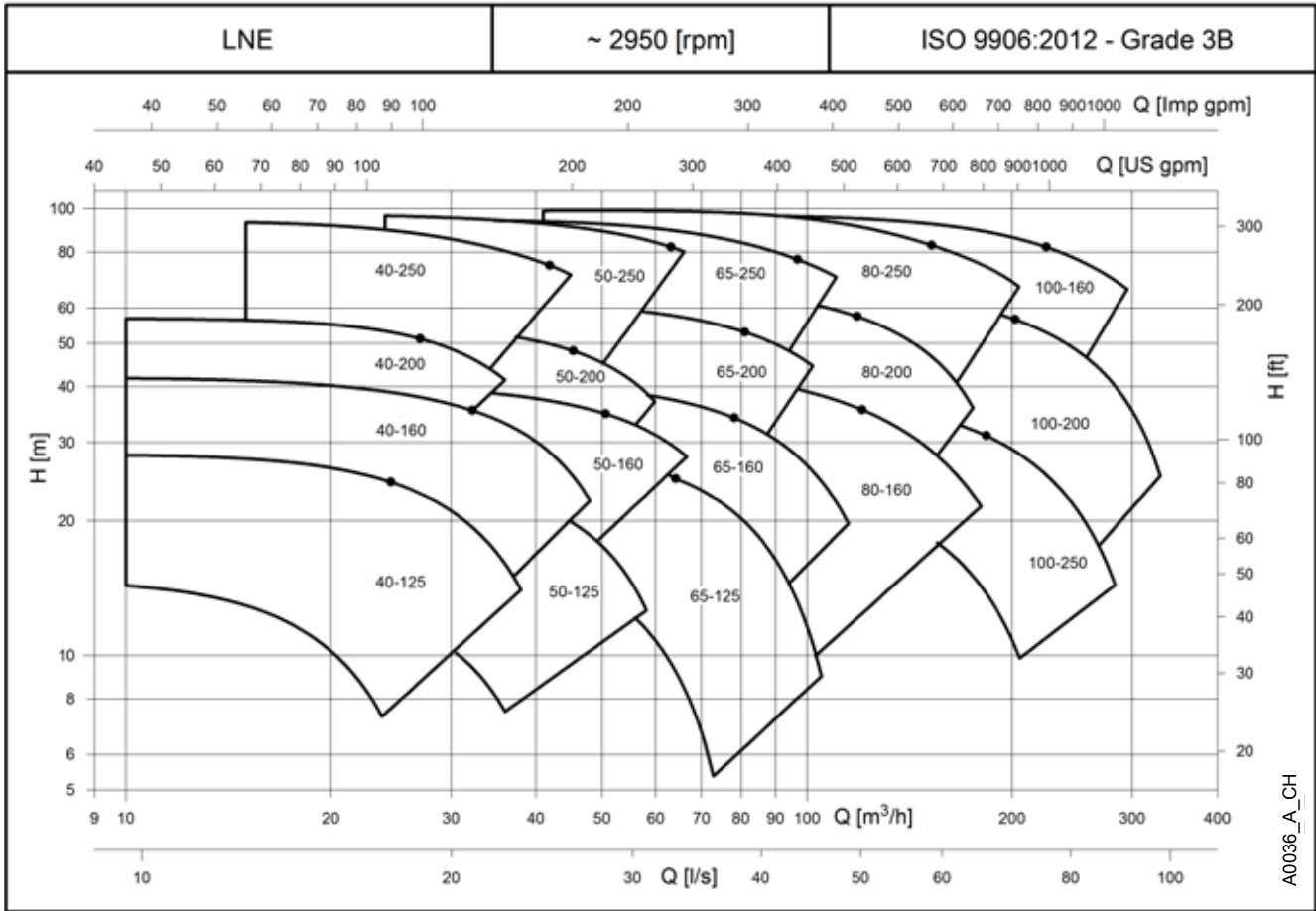

e-LNE 40, 50 SERIES

HYDRAULIC PERFORMANCE TABLE AT 50 Hz, 2 POLES

PUMP TYPE	P _N kW	ØF (1)	η _p % (2)	ØT (3)	Q = DELIVERY												
					l/s	1,7	2,8	3,8	4,9	6,0	7,0	8,1	9,1	10,2	11,2	12,3	13,3
					0	6	10	14	18	21	25	29	33	37	40	44	48
					H = TOTAL HEAD METRES COLUMN OF WATER												
40-125/11	1,1		61,6	106	14,3	14,6	14,3	13,4	11,7	9,2							
40-125/15	1,5		63,1	117	17,6		17,8	17,1	15,7	13,7	11,0						
40-125/22	2,2		65,2	132	22,7		23,0	22,5	21,6	20,0	17,9	15,1	11,7				
40-125/30	3	145	67,0		27,6		28,1	27,8	27,0	25,8	24,1	21,8	18,9	15,4			
40-160/30	3		68,1	147	29,9		30,3	29,8	29,0	27,8	26,1	24,0	21,3				
40-160/40	4		69,6	160	35,7		36,3	35,9	35,1	34,1	32,7	30,9	28,7	26,0			
40-160/55	5,5	171	70,9		41,1		41,7	41,4	40,8	39,8	38,6	37,0	35,1	32,7	29,8	26,4	22,2
40-200/40	4		55,6	169	38,4		37,7	37,2	35,8	33,4	29,7						
40-200/55	5,5		57,3	186	47,0		46,2	45,8	44,9	43,1	40,3	36,4					
40-200/75	7,5	205	59,2		57,9		56,8	56,5	55,8	54,5	52,5	49,5	45,5				
40-250/92	9,2		55,9	226	69,4			69,6	68,4	66,5	63,9	60,9					
40-250/110A	11		55,9	226	69,4			69,6	68,4	66,5	63,9	60,9					
40-250/110	11		57,0	239	78,3			78,5	77,5	75,8	73,4	70,5	67,3				
40-250/150	15	259	58,6		93,0				92,6	91,1	89,0	86,4	83,3	79,9	76,3	72,2	

PUMP TYPE	P _N kW	ØF (1)	η _p % (2)	ØT (3)	Q = DELIVERY												
					l/s	2,7	4,1	5,5	7,0	8,4	9,9	11,3	12,7	14,2	15,6	17,1	18,5
					0	10	15	20	25	30	35	41	46	51	56	61	67
					H = TOTAL HEAD METRES COLUMN OF WATER												
50-125/15	1,5		66,7	101	14,6	14,2	13,8	13,1	11,9	10,2	7,8						
50-125/22	2,2		68,4	113	18,5		17,7	17,1	16,2	14,9	13,0	10,5					
50-125/30	3		70,0	124	22,4		21,6	21,1	20,4	19,3	17,8	15,8	13,3				
50-125/40	4	136	71,8		27,2			25,9	25,3	24,4	23,1	21,6	19,5	17,0	13,9		
50-160/40	4		70,5	136	26,5		26,9	26,6	26,0	25,2	24,0	22,5	20,5				
50-160/55	5,5		72,1	150	32,6		33,0	32,8	32,4	31,7	30,7	29,5	27,9	26,0	23,7		
50-160/75	7,5	165	73,8		39,8			40,2	39,9	39,3	38,5	37,5	36,2	34,6	32,7	30,5	27,9
50-200/75	7,5		61,5	177	42,9		43,2	42,8	42,1	40,8	38,9	36,2	32,7	28,2			
50-200/92	9,2		62,5	188	48,8			48,8	48,1	47,1	45,5	43,2	40,2	36,4	31,6		
50-200/110A	11		62,5	188	48,8			48,8	48,1	47,1	45,5	43,2	40,2	36,4	31,6		
50-200/110	11	199	63,6		55,0			55,1	54,5	53,6	52,2	50,3	47,8	44,5	40,4	35,4	
50-250/110	11		62,1	208	60,5			61,7	60,8	59,6	57,9	55,7	53,1				
50-250/150	15		63,6	228	73,6				74,3	73,3	71,8	70,0	67,8	65,1			
50-250/185	18,5		64,8	243	84,3				85,3	84,3	83,0	81,4	79,4	77,0	74,2		
50-250/220	22	257	65,8		95,0				96,3	95,4	94,2	92,7	90,8	88,7	86,2	83,2	

PUMP TYPE	P _N kW	ØF (1)	η _p % (2)	ØT (3)	Q = DELIVERY												
					l/s	5,017	7	9,914	12,36	14,81	17,26	19,71	22,16	24,61	27,06	29,505	31,954
					0	18	27	36	45	53	62	71	80	89	97	106	115
					H = TOTAL HEAD METRES COLUMN OF WATER												
65-125/30	3		70,9	116	18,3	17,7	17,3	16,5	15,1	12,9	10,0	6,3					
65-125/40	4		72,3	126	21,7		20,8	20,1	19,0	17,2	14,8	11,6	7,7				
65-125/55	5,5		74,1	139	26,7		25,7	25,1	24,3	22,9	21,0	18,4	15,2	11,4			
65-125/75	7,5	148	75,3		30,4		29,4	28,9	28,1	27,0	25,3	23,1	20,3	16,9	12,9		
65-160/75	7,5		71,4	156	33,4		32,0	31,4	30,4	29,1	27,3	25,0	22,1	18,7			
65-160/92	9,2		72,6	166	38,1		36,6	36,0	35,1	33,9	32,4	30,4	27,8	24,8	21,2		
65-160/110A	11		72,6	166	38,1		36,6	36,0	35,1	33,9	32,4	30,4	27,8	24,8	21,2		
65-160/110	11	176	73,7		43,0		41,5	40,9	40,1	39,0	37,6	35,8	33,6	30,9	27,7	24,0	19,7
65-200/110	11		69,0	179	43,7		44,8	44,1	42,9	41,2	39,0	36,3	32,8				
65-200/150	15		70,7	197	53,5		54,9	54,4	53,4	52,0	50,1	47,8	45,0	41,5			
65-200/185	18,5	209	71,8		60,6		62,2	61,8	60,9	59,6	58,0	55,9	53,3	50,3	46,6		
65-250/150	15		67,6	207	59,2		60,3	59,6	58,1	55,7	52,8	49,5	45,7				
65-250/185	18,5		68,6	220	67,3		68,5	68,0	66,7	64,7	62,0	58,8	55,3				
65-250/220	22		69,5	232	75,3			76,2	75,2	73,3	70,9	67,9	64,5	60,7			
65-250/300	30	256	71,4		92,7			94,0	93,3	91,9	89,8	87,2	84,2	80,7	76,8	72,6	

Hydraulic performances in compliance with ISO 9906:2012 - Grade 3B (ex ISO 9906:1999 - Annex A)

LNE-40-50-65_2p50-en_a_th

(1) External diameter of full impeller (2) Hydraulic efficiency of pump (3) External diameter of trimmed impeller *Available also in single-phase version.

e-LNE 65, 80, 100 SERIES HYDRAULIC PERFORMANCE TABLE AT 50 Hz, 2 POLES

PUMP TYPE	P _N kW	ØF (1)	ηp % (2)	ØT (3)	Q = DELIVERY												
					l/s	7	11,25	15,49	19,73	23,97	28,21	32,45	36,69	40,94	45,18	49,417	54
					0	25	40	56	71	86	102	117	132	147	163	178	193
					H = TOTAL HEAD METRES COLUMN OF WATER												
80-160/75	7,5		75,9	142	28,1	27,6	26,8	25,6	23,8	21,5	18,7	15,4					
80-160/92	9,2		75,9	142	31,9		30,7	29,6	27,9	25,8	23,1	20,0	16,5				
80-160/110A	11		76,9	151	31,9		30,7	29,6	27,9	25,8	23,1	20,0	16,5				
80-160/110	11		77,7	159	35,6		34,4	33,3	31,8	29,7	27,2	24,3	21,0	17,2			
80-160/150	15,0		79,5	175	43,5		42,5	41,4	40,0	38,1	35,9	33,3	30,2	26,8	23,0		
80-160/185	18,5	180	80,1		46,2		45,2	44,1	42,7	40,9	38,7	36,2	33,2	29,9	26,2	22,2	
80-200/185	18,5		72,6	189	49,9		50,2	48,7	46,5	43,7	40,2	35,7	29,7				
80-200/220	22		73,5	199	55,6		56,2	54,7	52,6	50,0	46,7	42,7	37,6	30,8			
80-200/300	30	220	75,4		68,6		69,7	68,4	66,5	64,1	61,2	57,8	53,7	48,6	42,3		
80-250/370	37	229	75,2		76,0		77,2	77,0	75,9	73,8	70,9	67,5	63,7	59,7	55,3	49,8	41,3

PUMP TYPE	P _N kW	ØF (1)	ηp % (2)	ØT (3)	Q = DELIVERY												
					l/s	12	18,83	25,43	32,03	38,63	45,24	51,84	58,44	65,04	71,64	78,246	85
					0	44	68	92	115	139	163	187	210	234	258	282	305
					H = TOTAL HEAD METRES COLUMN OF WATER												
100-160/110	11		76,3	144	26,7												
100-160/150	15		77,9	158	32,4												
100-160/185	18,5		79,0	168	36,8												
100-160/220	22	177	80,0		41,1												
100-200/220	22		77,5	178	44,1												
100-200/300	30		79,1	195	53,3												
100-200/370	37	208	80,3		61,0												
100-250/370	37	214	76,7		65,0			64,9	64,7	64,2	63,4	62,2	60,6	58,7	56,4	53,8	50,9

Hydraulic performances in compliance with ISO 9906:2012 - Grade 3B (ex ISO 9906:1999 - Annex A)

LNE-80-100_2p50-en_a_th

(1) External diameter of full impeller (2) Hydraulic efficiency of pump (3) External diameter of trimmed impeller

e-LNE SERIES

HYDRAULIC PERFORMANCE RANGE AT 50 Hz, 4 POLES

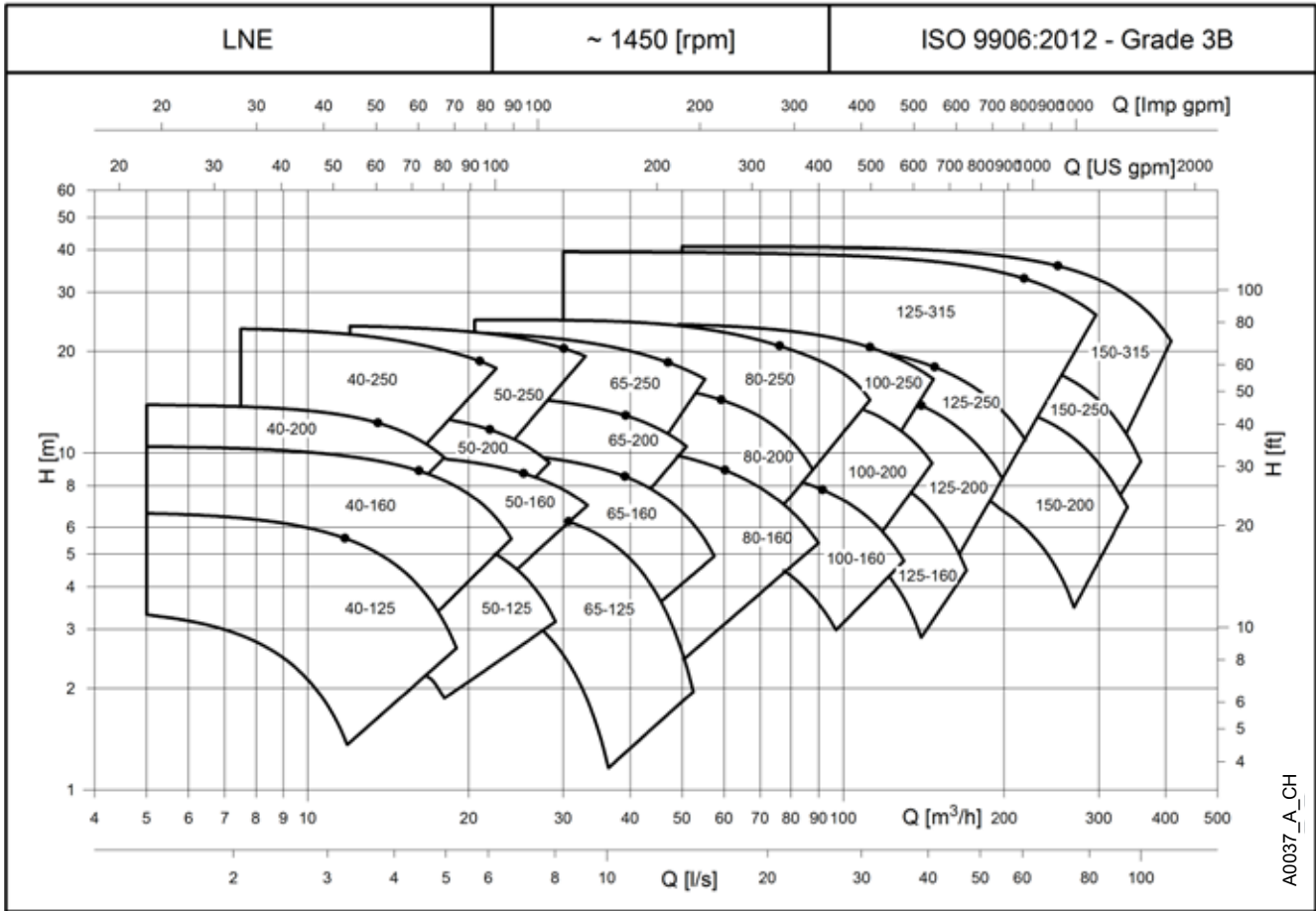

e-LNE 40, 50, 65 SERIES

HYDRAULIC PERFORMANCE RANGE AT 50 Hz, 4 POLES

PUMP TYPE	P _N kW	ØF (1)	ηp % (2)	ØT (3)	Q = DELIVERY												
					l/s	0,9	1,4	1,9	2,4	3,0	3,5	4,0	4,6	5,1	5,6	6,1	6,7
					m ³ /h	3	5	7	9	11	13	15	16	18	20	22	24
H = TOTAL HEAD METRES COLUMN OF WATER																	
40-125/02B	0,25		57,4	106	3,4	3,4	3,3	3,0	2,5	1,9							
40-125/02A	0,25		58,9	117	4,2		4,1	3,9	3,5	2,9	2,2						
40-125/02	0,25		61,1	132	5,4		5,4	5,2	4,9	4,4	3,8	3,1	2,2				
40-125/03	0,37	145	62,9		6,5		6,6	6,5	6,2	5,8	5,3	4,7	3,9	3,0			
40-160/03	0,37		63,5	147	7,2		7,3	7,2	7,0	6,6	6,2	5,6	4,8				
40-160/05	0,55		65,0	160	8,6		8,7	8,6	8,5	8,2	7,8	7,3	6,7	5,9			
40-160/07	0,75	171	66,4		9,8		10,0	10,0	9,8	9,6	9,2	8,8	8,3	7,6	6,8	5,8	4,7
40-200/05	0,55		53,0	169	9,5		9,2	9,0	8,6	8,0	7,0						
40-200/07	0,75		54,6	186	11,6		11,3	11,1	10,9	10,4	9,6	8,6					
40-200/11	1,1	205	56,5		14,3		13,9	13,8	13,6	13,2	12,6	11,8	10,8				
40-250/11	1,1		51,0	212	15,1			14,7	14,3	13,7	13,0	12,1	11,0				
40-250/15A	1,5		52,1	226	17,3			17,0	16,6	16,0	15,4	14,5	13,6	12,4			
40-250/15	1,5		53,0	239	19,5			19,2	18,8	18,3	17,7	16,9	16,0	15,0			
40-250/22	2,2	259	54,5		23,2				22,6	22,1	21,5	20,8	20,0	19,1	18,0	16,7	15,1

PUMP TYPE	P _N kW	ØF (1)	ηp % (2)	ØT (3)	Q = DELIVERY												
					l/s	1,3	2,1	2,8	3,5	4,2	4,9	5,7	6,4	7,1	7,8	8,5	9,3
					m ³ /h	5	7	10	13	15	18	20	23	26	28	31	33
H = TOTAL HEAD METRES COLUMN OF WATER																	
50-125/02A	0,25		64,8	101	3,3	3,3	3,2	3,0	2,6	2,1	1,5						
50-125/02	0,25		66,6	113	4,2		4,0	3,9	3,6	3,3	2,7	2,1					
50-125/03	0,37		68,2	124	5,1		5,0	4,8	4,6	4,3	3,9	3,3	2,7				
50-125/05	0,55	136	70,0		6,2			5,9	5,8	5,5	5,2	4,7	4,2	3,5	2,7		
50-160/05	0,55		66,3	136	6,5		6,5	6,4	6,3	6,1	5,8	5,4	4,9				
50-160/07	0,75		68,0	150	8,0		8,0	7,9	7,8	7,7	7,4	7,1	6,7	6,2	5,5		
50-160/11	1,1	165	69,7		9,8			9,7	9,7	9,5	9,3	9,1	8,7	8,3	7,8	7,2	6,5
50-200/11A	1,1		59,1	177	10,5		10,5	10,4	10,2	9,9	9,3	8,6	7,7	6,5			
50-200/11	1,1		60,2	188	11,9			11,9	11,7	11,4	11,0	10,3	9,5	8,5	7,3		
50-200/15	1,5	199	61,3		13,5			13,4	13,3	13,0	12,6	12,1	11,4	10,5	9,4	8,1	
50-250/15	1,5		60,6	208	15,2			15,2	15,0	14,6	14,2	13,6	12,8				
50-250/22A	2,2		62,2	228	18,4				18,3	18,0	17,7	17,1	16,5	15,8			
50-250/22	2,2		63,4	243	21,1				21,0	20,8	20,4	20,0	19,4	18,8	18,0		
50-250/30	3	257	64,4		23,8				23,7	23,5	23,2	22,8	22,3	21,7	21,0	20,2	

PUMP TYPE	P _N kW	ØF (1)	ηp % (2)	ØT (3)	Q = DELIVERY												
					l/s	2,5	4	4,95	6,176	7,401	8,626	9,851	11,08	12,3	13,53	14,752	15,977
					m ³ /h	9	13	18	22	27	31	35	40	44	49	53	58
H = TOTAL HEAD METRES COLUMN OF WATER																	
65-125/03	0,37		70,0	116	4,5	4,4	4,2	4,1	3,7	3,1	2,3	1,4					
65-125/05	0,55		71,4	126	5,3		5,1	4,9	4,7	4,2	3,5	2,7	1,7				
65-125/07	0,75		73,2	139	6,5		6,3	6,2	6,0	5,6	5,1	4,4	3,5	2,5			
65-125/11	1,1	148	74,5		7,4		7,2	7,1	6,9	6,6	6,2	5,6	4,9	3,9	2,9		
65-160/11A	1,1		68,7	156	8,2		7,8	7,6	7,4	7,0	6,6	6,0	5,2	4,3			
65-160/11	1,1		69,8	166	9,4		8,9	8,7	8,5	8,2	7,8	7,3	6,7	5,9	4,9		
65-160/15	1,5	176	70,9		10,6		10,1	9,9	9,7	9,5	9,1	8,7	8,1	7,4	6,6	5,6	4,5
65-200/15	1,5		67,8	179	11,0		10,9	10,7	10,4	9,9	9,4	8,6	7,7				
65-200/22A	2,2		69,4	197	13,5		13,4	13,2	12,9	12,6	12,1	11,5	10,7	9,8			
65-200/22	2,2	209	70,5		15,3		15,2	15,0	14,8	14,4	14,0	13,5	12,8	12,0	11,0		
65-250/22	2,2		67,0	220	16,8		16,7	16,4	16,1	15,5	14,8	14,0	13,0				
65-250/30	3		67,9	232	18,8			18,5	18,1	17,6	16,9	16,2	15,3	14,3			
65-250/40	4	256	69,8		23,1			22,8	22,6	22,1	21,6	20,9	20,0	19,1	18,2	17,1	

Hydraulic performances in compliance with ISO 9906:2012 - Grade 3B (ex ISO 9906:1999 - Annex A)

LNE-40-50-65_4p50-en_a_th

(1) External diameter of full impeller (2) Hydraulic efficiency of pump (3) External diameter of trimmed impeller *Available also in single-phase version.

e-LNE 80, 100 SERIES

HYDRAULIC PERFORMANCE RANGE AT 50 Hz, 4 POLES

PUMP TYPE	P _N kW	ØF (1)	η _p % (2)	ØT (3)	Q = DELIVERY													
					l/s	4	6,098	8,697	11,3	13,89	16,49	19,09	21,69	24,29	26,89	29,485	32	
					0	13	22	31	41	50	59	69	78	87	97	106	116	
					H = TOTAL HEAD METRES COLUMN OF WATER													
80-160/11A	1,1		73,5	142	7,0	6,9	6,6	6,1	5,5	4,6	3,6							
80-160/15B	1,5		73,5	142	7,0	6,9	6,6	6,1	5,5	4,6	3,6							
80-160/11	1,1		74,5	151	8,0		7,6	7,1	6,5	5,7	4,8	3,6						
80-160/15A	1,5		74,5	151	8,0		7,6	7,1	6,5	5,7	4,8	3,6						
80-160/15	1,5		75,4	159	8,9		8,5	8,1	7,5	6,7	5,8	4,8						
80-160/22A	2,2		77,2	175	10,9		10,5	10,1	9,6	8,9	8,1	7,1	6,0					
80-160/22	2	180	77,8		11,5		11,2	10,8	10,3	9,6	8,8	7,8	6,7	5,5				
80-200/22	2,2		73,4	189	12,8		12,3	11,9	11,2	10,1	8,6	6,7						
80-200/30	3		74,4	199	31,1		30,3	28,4	25,0	20,2		8,6						
80-200/40	4	220	76,3		17,6		17,1	16,8	16,2	15,4	14,3	12,8	11,0	8,9				
80-250/55A	5,5		73,3	229	18,7		19,0	18,9	18,5	17,6	16,4	15,0	13,6	12,4				
80-250/55	5,5		74,5	243	21,2		21,5	21,4	21,1	20,4	19,3	17,9	16,5	15,1	13,8			
80-250/75	7,5	258	75,7		27,9		27,9	26,7	24,4	21,0	16,8	12,2	19,8	18,3	16,9	15,6	14,0	

PUMP TYPE	P _N kW	ØF (1)	η _p % (2)	ØT (3)	Q = DELIVERY													
					l/s	6	9,727	13,34	16,95	20,56	24,17	27,78	31,39	35	38,61	42,223	46	
					0	22	35	48	61	74	87	100	113	126	139	152	165	
					H = TOTAL HEAD METRES COLUMN OF WATER													
100-160/15	1,5		76,0	144	6,6	6,3	6,1	5,8	5,3	4,6	3,7	2,7						
100-160/22A	2,2		77,6	158	8,0		7,5	7,3	6,9	6,3	5,5	4,5	3,5					
100-160/22	2,2		78,7	168	9,1		8,6	8,4	8,0	7,5	6,8	5,9	4,9	3,7				
100-160/30	3	177	79,7		10,1		9,7	9,4	9,1	8,6	7,9	7,1	6,2	5,1	3,9			
100-200/30	3		77,1	178	11,3		10,8	10,3	9,7	8,9	7,8	6,5	5,1					
100-200/40	4		78,7	195	13,7		13,1	12,8	12,2	11,5	10,5	9,4	8,1	6,6				
100-200/55A	5,5		80,0	208	15,6		15,1	14,7	14,2	13,6	12,7	11,7	10,5	9,1	7,5	5,7		
100-200/55	5,5	219	81,0		17,4		16,9	16,5	16,1	15,4	14,6	13,7	12,5	11,2	9,7	8,1	6,3	
100-250/55A	5,5		77,3	214	16,5		16,0	15,7	15,2	14,4	13,4	12,2						
100-250/55	5,5		78,2	227	18,7		18,1	17,8	17,4	16,7	15,8	14,7	13,4					
100-250/75	7,5		79,3	241	21,2		20,6	20,3	19,9	19,3	18,5	17,5	16,3	14,9				
100-250/110	11	259	80,6		24,6		24,0	23,7	23,3	22,8	22,1	21,2	20,2	18,9	17,4			

Hydraulic performances in compliance with ISO 9906:2012 - Grade 3B (ex ISO 9906:1999 - Annex A)

LNE-80-100_4p50-en_a_th

(1) External diameter of full impeller (2) Hydraulic efficiency of pump (3) External diameter of trimmed impeller

e-LNE 125, 150 SERIES

HYDRAULIC PERFORMANCE TABLE AT 50 Hz, 4 POLES

PUMP TYPE	P _N kW	ØF (1)	η _p % (2)	ØT (3)	Q = DELIVERY													
					l/s	0	5	13,13	21,26	29,39	37,53	45,66	53,79	61,92	70,05	78,18	86,313	94
					m ³ /h	0	18	47	77	106	135	164	194	223	252	281	311	340
H = TOTAL HEAD METRES COLUMN OF WATER																		
125-160/22	2,2		75,2	156	7,3	7,4	7,1	6,5	5,3	3,3								
125-160/30	3		78,2	176	9,5		9,3	8,6	7,4	5,4								
125-160/40	4	190	80,2		11,3		10,9	10,4	9,3	7,6	5,0							
125-200/55	5,5		81,1	213	14,6		14,5	14,1	13,2	11,5	9,0							
125-200/75	7,5	229	81,7		17,2		17,0	16,6	15,7	14,2	11,8	8,9						
125-250/75	7,5		79,9	234	18,0		17,9	17,3	16,2	14,5	12,2	9,4						
125-250/110	11	259	80,4		22,1		22,1	21,6	20,5	18,9	16,7	13,8						
125-315/150	15		78,1	276	26,6		26,2	25,6	24,7	23,5	22,0	20,1	17,7	14,6				
125-315/185	18,5		79,6	295	30,7		30,3	29,8	28,9	27,8	26,3	24,5	22,2	19,4	16,1			
125-315/220	22		80,4	310	34,0		33,7	33,2	32,4	31,3	29,9	28,2	26,0	23,3	20,1	16,4		
125-315/300	30	334	80,5		39,6		39,3	39,0	38,4	37,5	36,2	34,6	32,5	30,1	27,2	24,1	20,6	

PUMP TYPE	P _N kW	ØF (1)	η _p % (2)	ØT (3)	Q = DELIVERY													
					l/s	0	10	19,19	28,66	38,13	47,6	57,07	66,54	76,01	85,48	94,95	104,42	114
					m ³ /h	0	35	69	103	137	171	205	240	274	308	342	376	410
H = TOTAL HEAD METRES COLUMN OF WATER																		
150-200/55	5,5		75,2	179	9,9	10,0	9,7	9,2	8,5	7,6	6,5	5,1						
150-200/75	7,5		79,4	204	13,1		12,7	12,3	11,7	10,8	9,8	8,4	6,6					
150-200/110	11	225	81,6		15,8		15,5	15,2	14,8	14,3	13,6	12,4	10,8	8,9				
150-250/110	11		80,2	235	17,8		17,6	17,4	16,9	16,0	14,7	13,0	10,9	8,4				
150-250/150	15	259	83,4		22,0		21,7	21,4	21,0	20,3	19,2	17,8	16,0	13,8	11,1			
150-315/185	18,5		79,5	277	26,8		26,4	25,9	25,1	23,9	22,2	20,0	17,4	14,2				
150-315/220	22		81,2	290	30,0		29,7	29,3	28,6	27,5	26,0	24,2	21,8	18,9	15,5			
150-315/300	30		82,6	315	36,0		36,0	35,8	35,2	34,4	33,1	31,5	29,3	26,7	23,5	19,8		
150-315/370	37	334	82,7		40,8		41,0	40,7	40,2	39,3	38,1	36,5	34,5	32,1	29,1	25,6	21,4	

Hydraulic performances in compliance with ISO 9906:2012 - Grade 3B (ex ISO 9906:1999 - Annex A)

LNE-125-150_4p50-en_b_th

(1) External diameter of full impeller (2) Hydraulic efficiency of pump (3) External diameter of trimmed impeller

e-LNE SERIES
OPERATING CHARACTERISTICS AT 50 Hz, 2 POLES

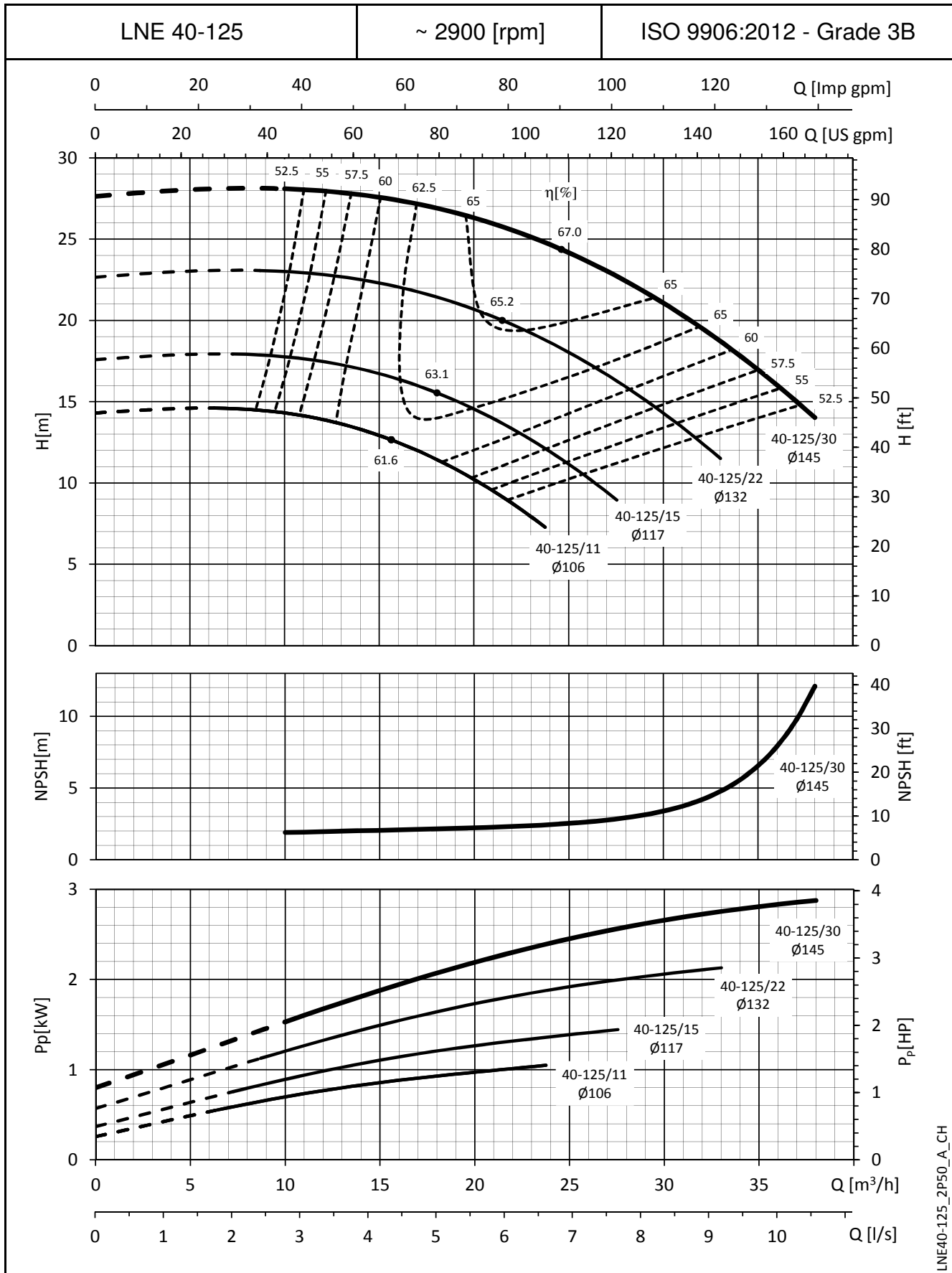

LNE40-125_2P50_A_CH

The NPSH values are laboratory values; for practical use we suggest increasing these values by 0,5 m.
 These performances are valid for liquids with density $\rho = 1,0 \text{ Kg/dm}^3$ and kinematic viscosity $\nu = 1 \text{ mm}^2/\text{sec}$.

e-LNE SERIES

OPERATING CHARACTERISTICS AT 50 Hz, 2 POLES

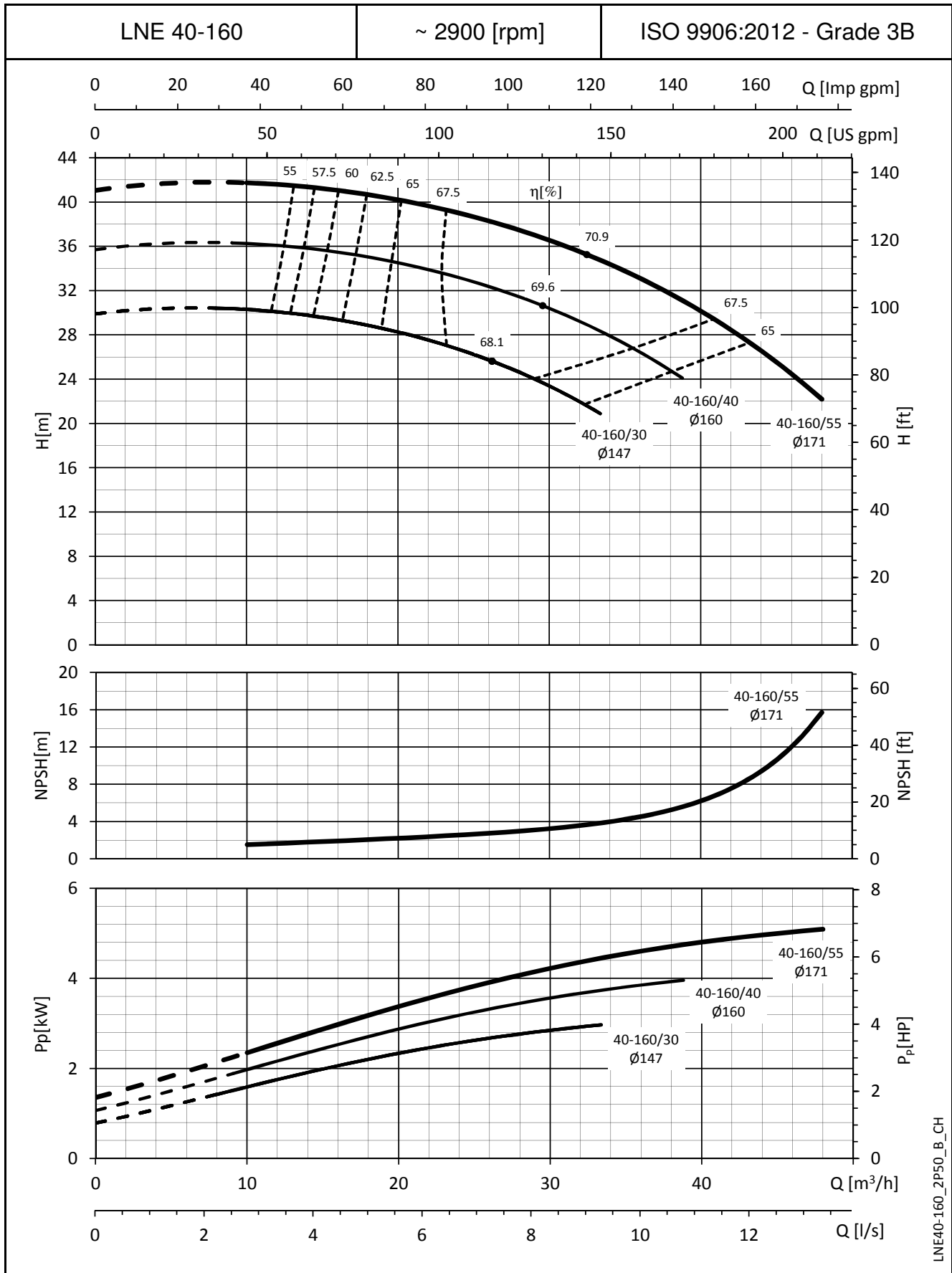

LNE40-160_2P50_B_CH

The NPSH values are laboratory values; for practical use we suggest increasing these values by 0,5 m.
 These performances are valid for liquids with density $\rho = 1,0 \text{ Kg/dm}^3$ and kinematic viscosity $\nu = 1 \text{ mm}^2/\text{sec}$.

e-LNE SERIES

OPERATING CHARACTERISTICS AT 50 Hz, 2 POLES

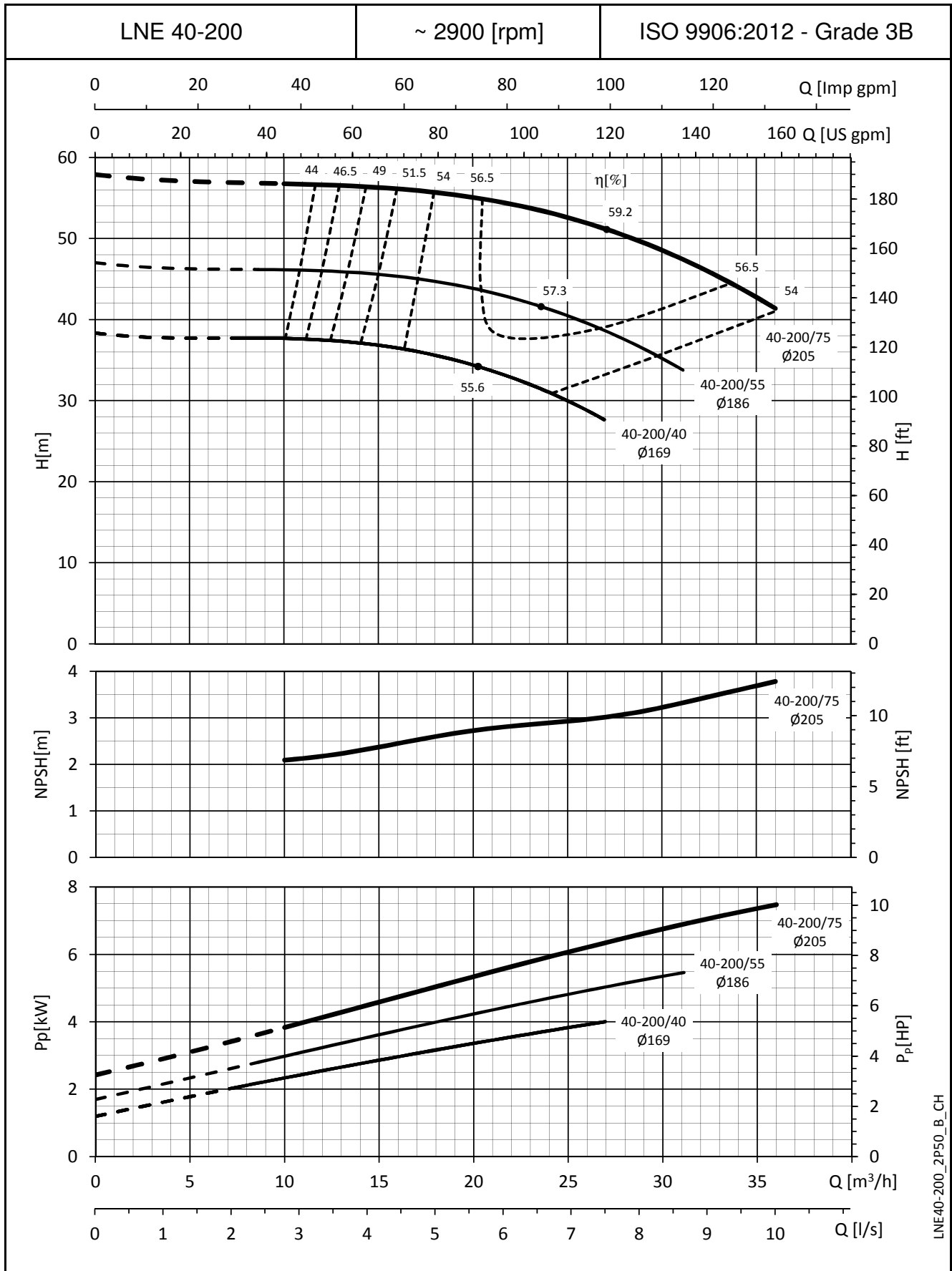

The NPSH values are laboratory values; for practical use we suggest increasing these values by 0,5 m.
 These performances are valid for liquids with density $\rho = 1,0 \text{ Kg/dm}^3$ and kinematic viscosity $\nu = 1 \text{ mm}^2/\text{sec}$.

e-LNE SERIES
OPERATING CHARACTERISTICS AT 50 Hz, 2 POLES

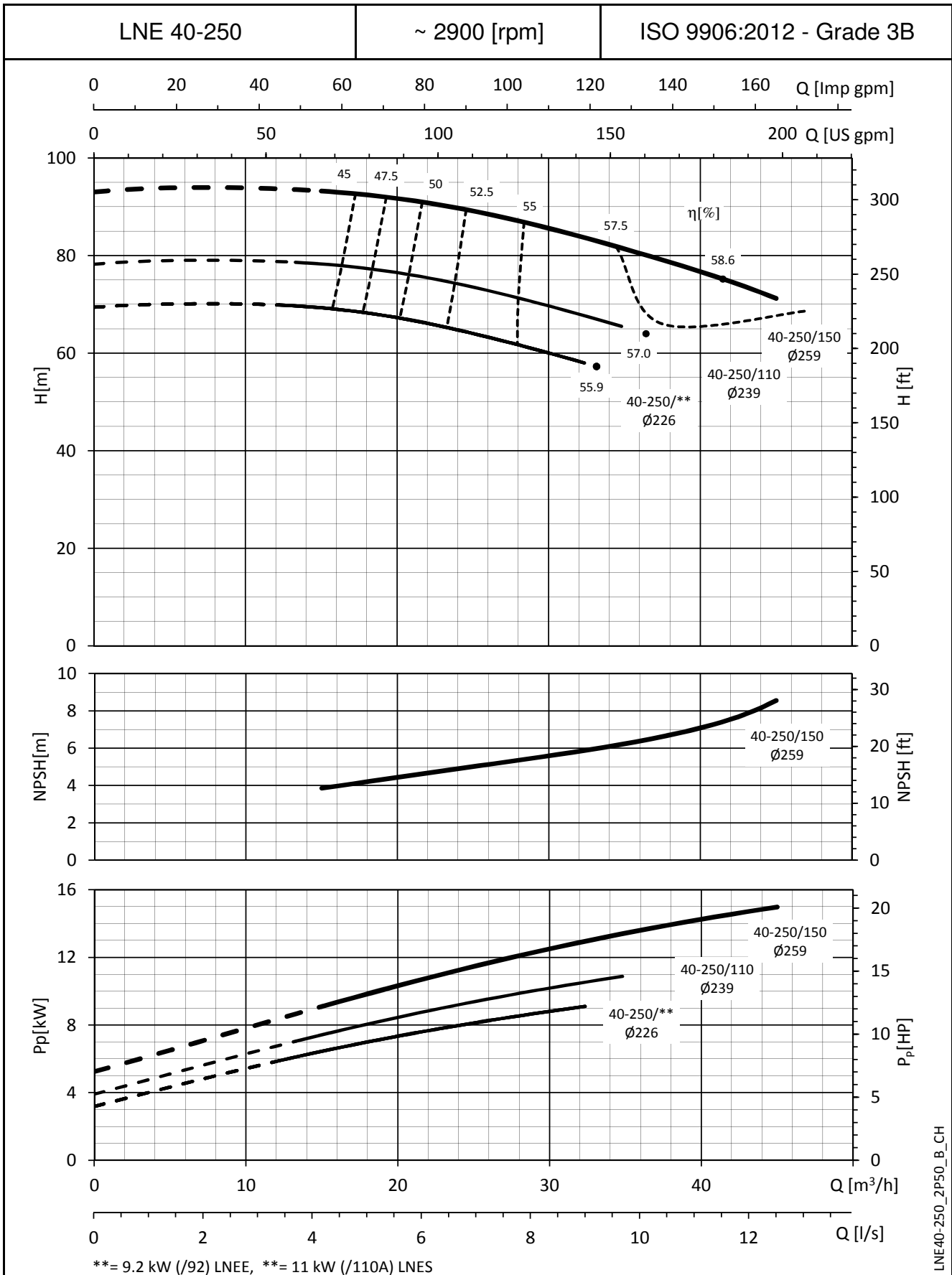

The NPSH values are laboratory values; for practical use we suggest increasing these values by 0,5 m.
 These performances are valid for liquids with density $\rho = 1,0 \text{ Kg/dm}^3$ and kinematic viscosity $\nu = 1 \text{ mm}^2/\text{sec}$.

e-LNE SERIES
OPERATING CHARACTERISTICS AT 50 Hz, 2 POLES

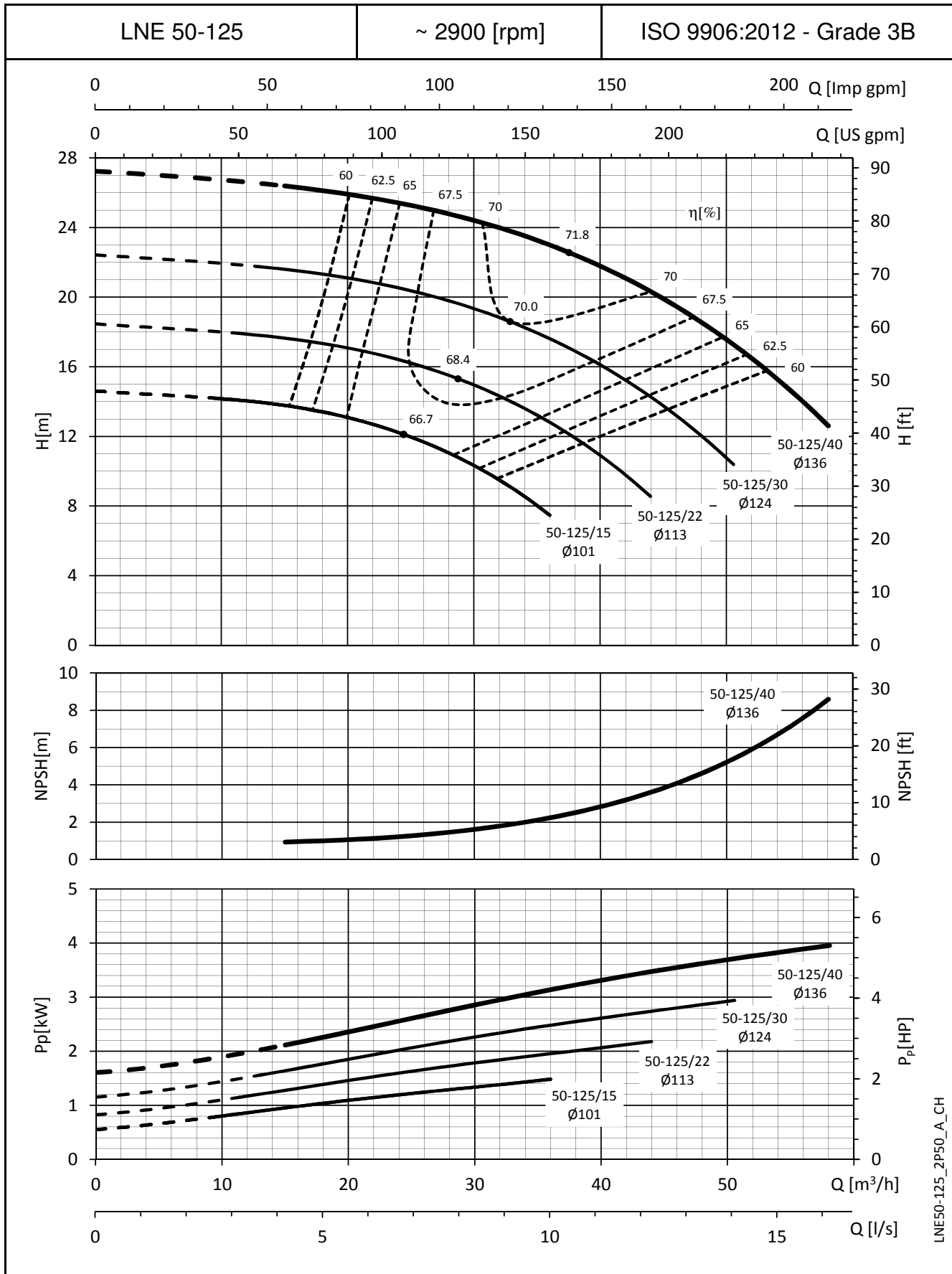

The NPSH values are laboratory values; for practical use we suggest increasing these values by 0,5 m.
 These performances are valid for liquids with density $\rho = 1,0 \text{ Kg/dm}^3$ and kinematic viscosity $\nu = 1 \text{ mm}^2/\text{sec}$.

e-LNE SERIES

OPERATING CHARACTERISTICS AT 50 Hz, 2 POLES

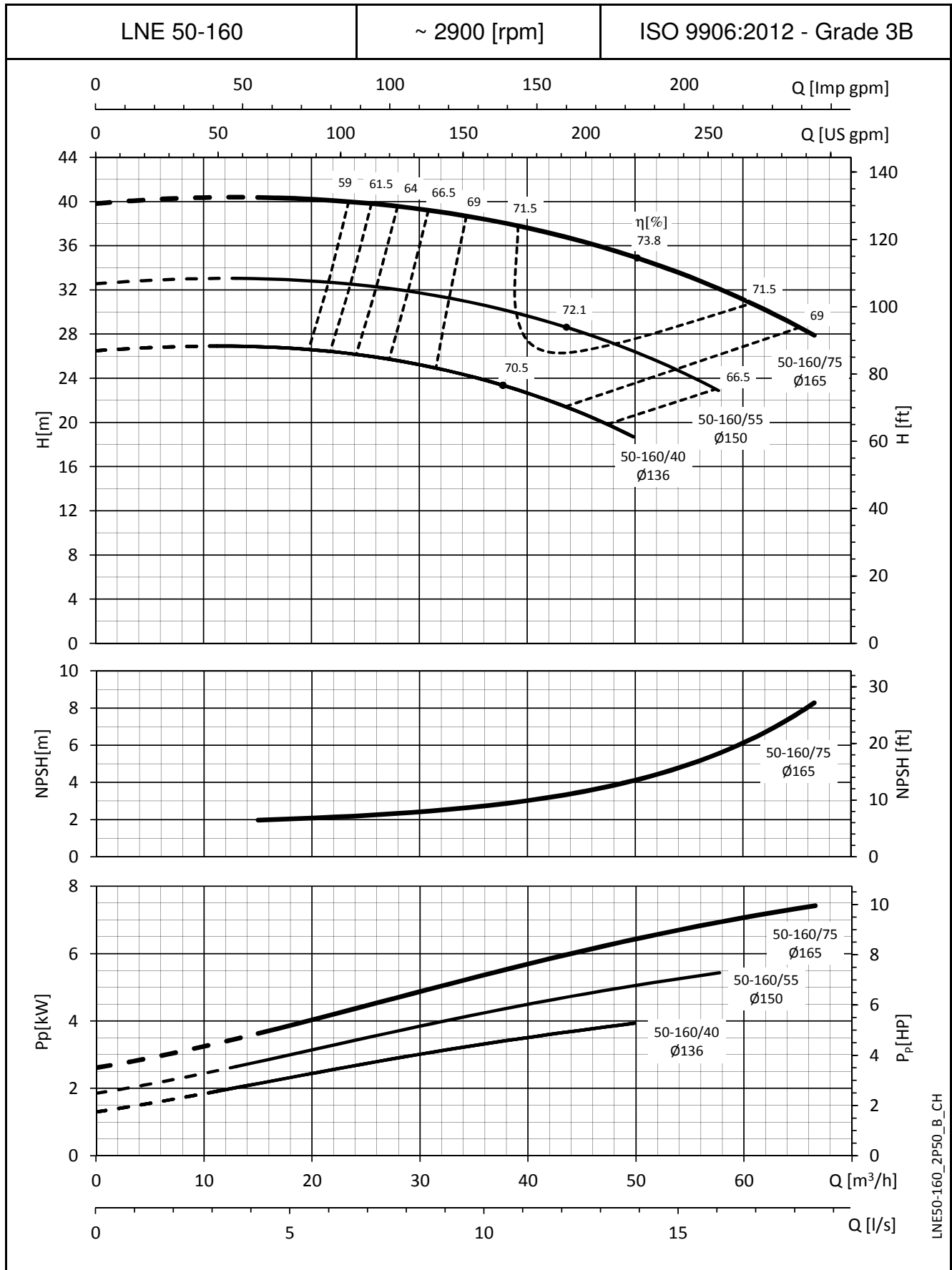

The NPSH values are laboratory values; for practical use we suggest increasing these values by 0,5 m.
 These performances are valid for liquids with density $\rho = 1,0 \text{ Kg/dm}^3$ and kinematic viscosity $\nu = 1 \text{ mm}^2/\text{sec}$.

e-LNE SERIES

OPERATING CHARACTERISTICS AT 50 Hz, 2 POLES

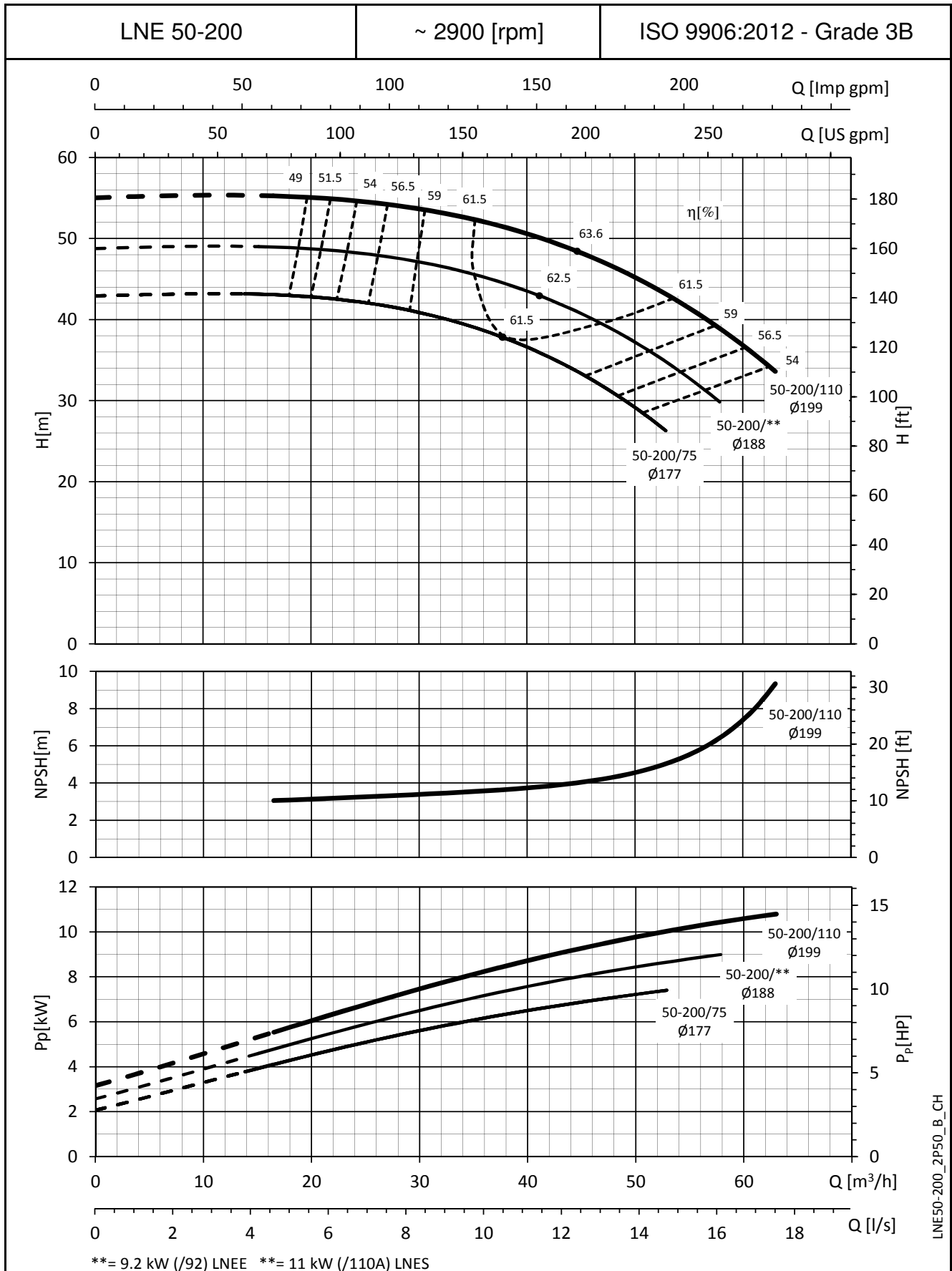

The NPSH values are laboratory values; for practical use we suggest increasing these values by 0,5 m.
 These performances are valid for liquids with density $\rho = 1,0 \text{ Kg/dm}^3$ and kinematic viscosity $\nu = 1 \text{ mm}^2/\text{sec}$.

e-LNE SERIES

OPERATING CHARACTERISTICS AT 50 Hz, 2 POLES

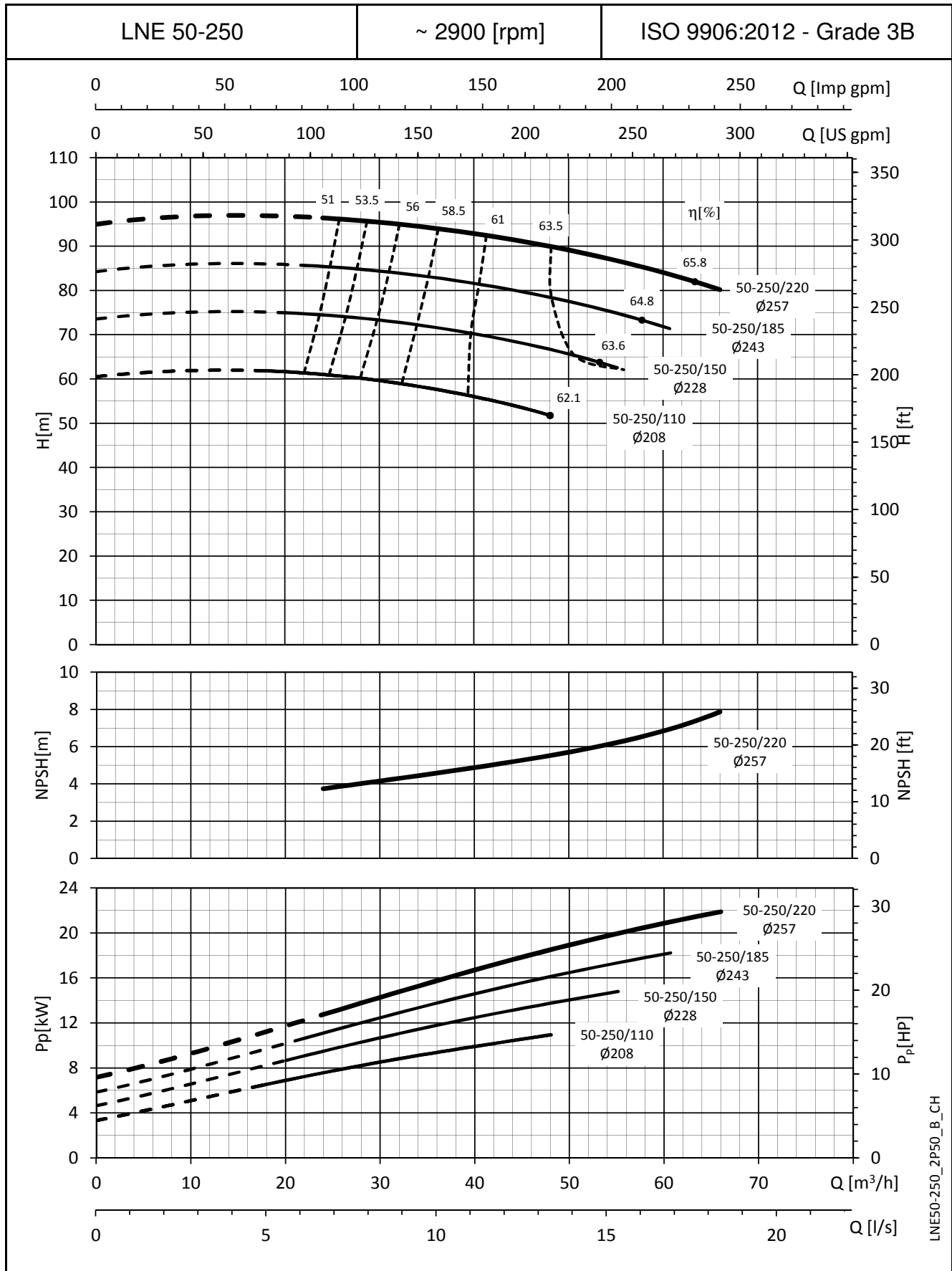

The NPSH values are laboratory values; for practical use we suggest increasing these values by 0,5 m.
 These performances are valid for liquids with density $\rho = 1,0 \text{ Kg/dm}^3$ and kinematic viscosity $\nu = 1 \text{ mm}^2/\text{sec}$.

e-LNE SERIES

OPERATING CHARACTERISTICS AT 50 Hz, 2 POLES

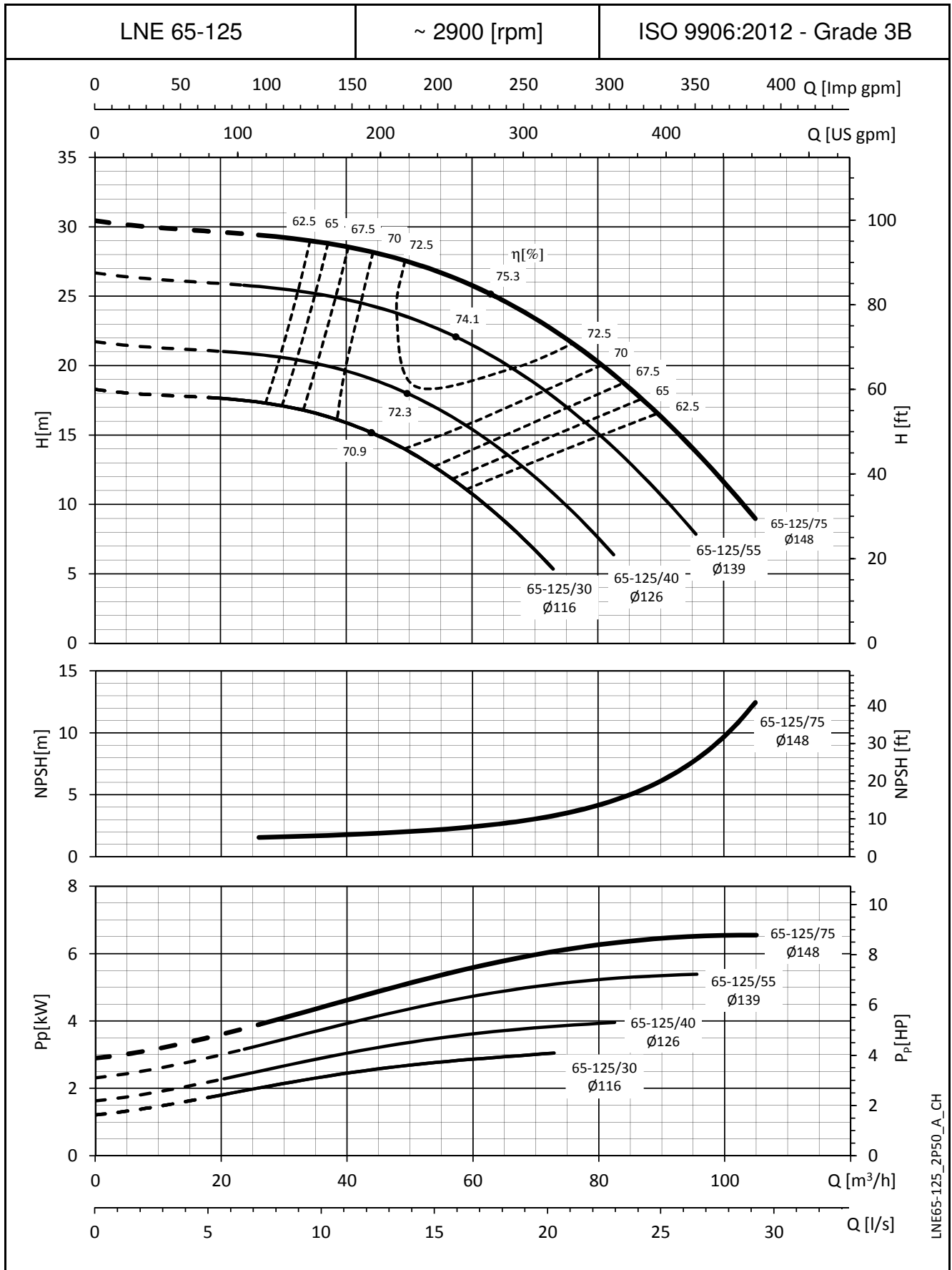

The NPSH values are laboratory values; for practical use we suggest increasing these values by 0,5 m.
 These performances are valid for liquids with density $\rho = 1,0 \text{ Kg/dm}^3$ and kinematic viscosity $\nu = 1 \text{ mm}^2/\text{sec}$.

e-LNE SERIES

OPERATING CHARACTERISTICS AT 50 Hz, 2 POLES

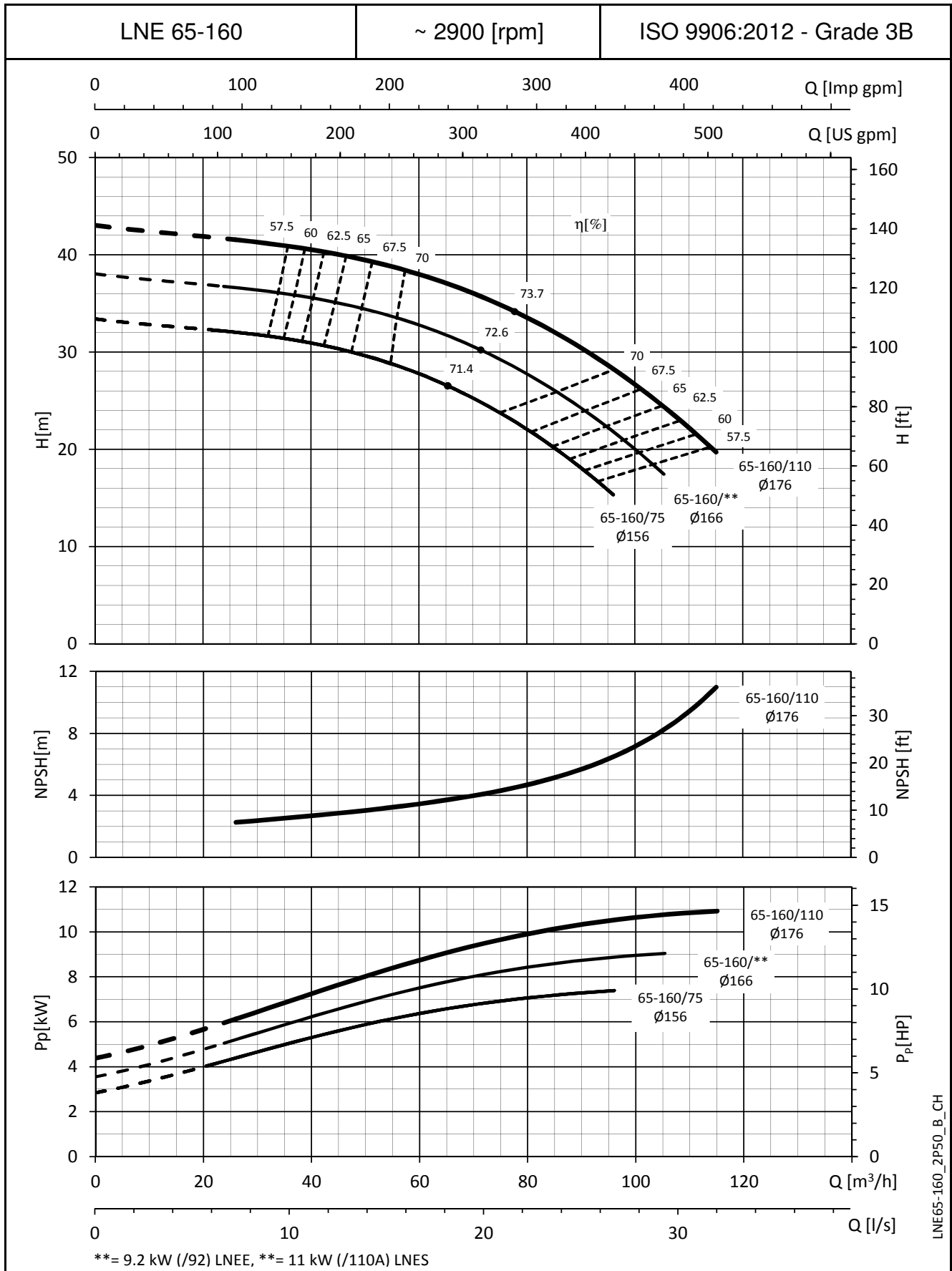

The NPSH values are laboratory values; for practical use we suggest increasing these values by 0,5 m.
 These performances are valid for liquids with density $\rho = 1,0 \text{ Kg/dm}^3$ and kinematic viscosity $\nu = 1 \text{ mm}^2/\text{sec}$.

e-LNE SERIES

OPERATING CHARACTERISTICS AT 50 Hz, 2 POLES

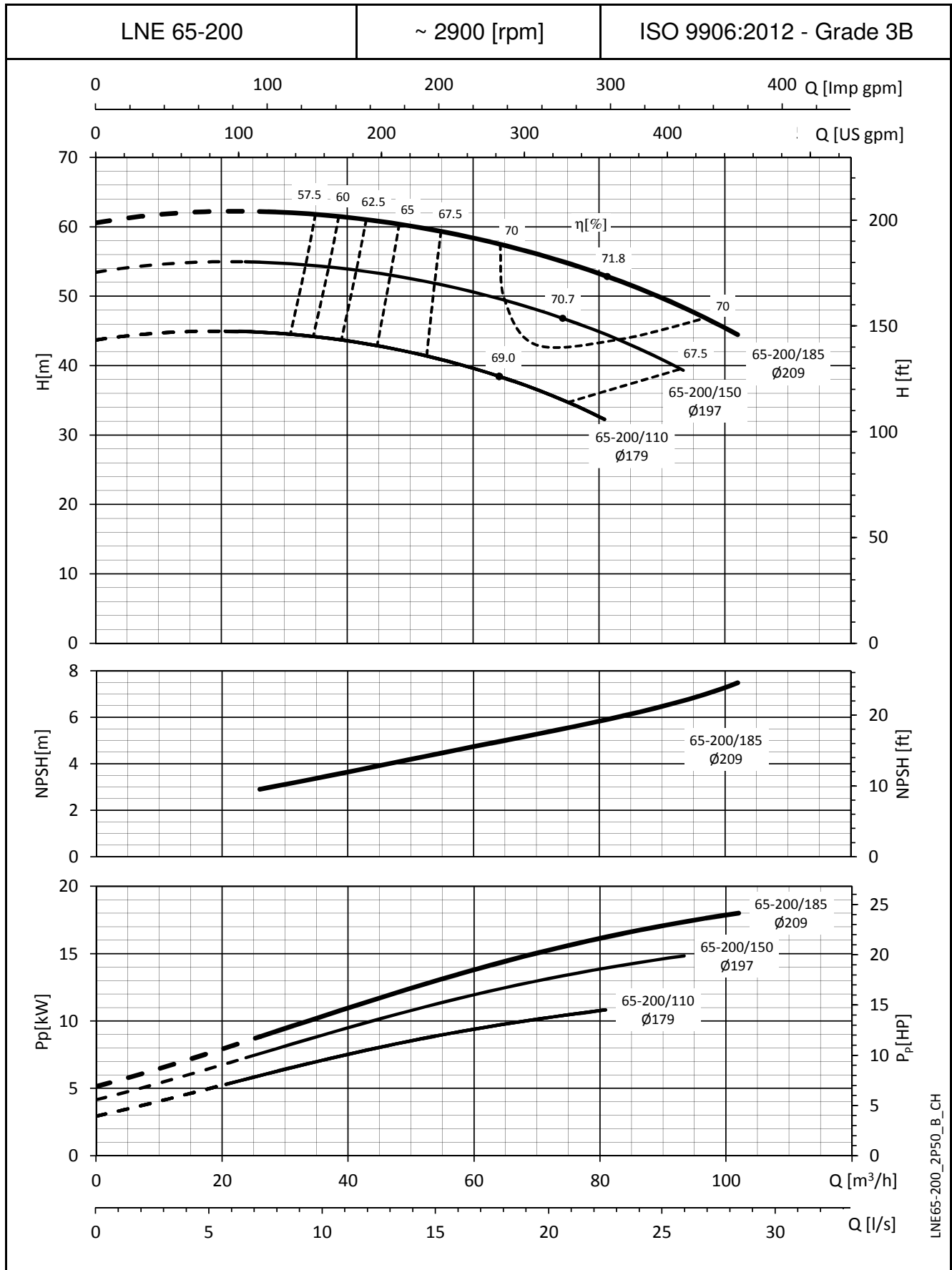

The NPSH values are laboratory values; for practical use we suggest increasing these values by 0,5 m.
 These performances are valid for liquids with density $\rho = 1,0 \text{ Kg/dm}^3$ and kinematic viscosity $\nu = 1 \text{ mm}^2/\text{sec}$.

e-LNE SERIES

OPERATING CHARACTERISTICS AT 50 Hz, 2 POLES

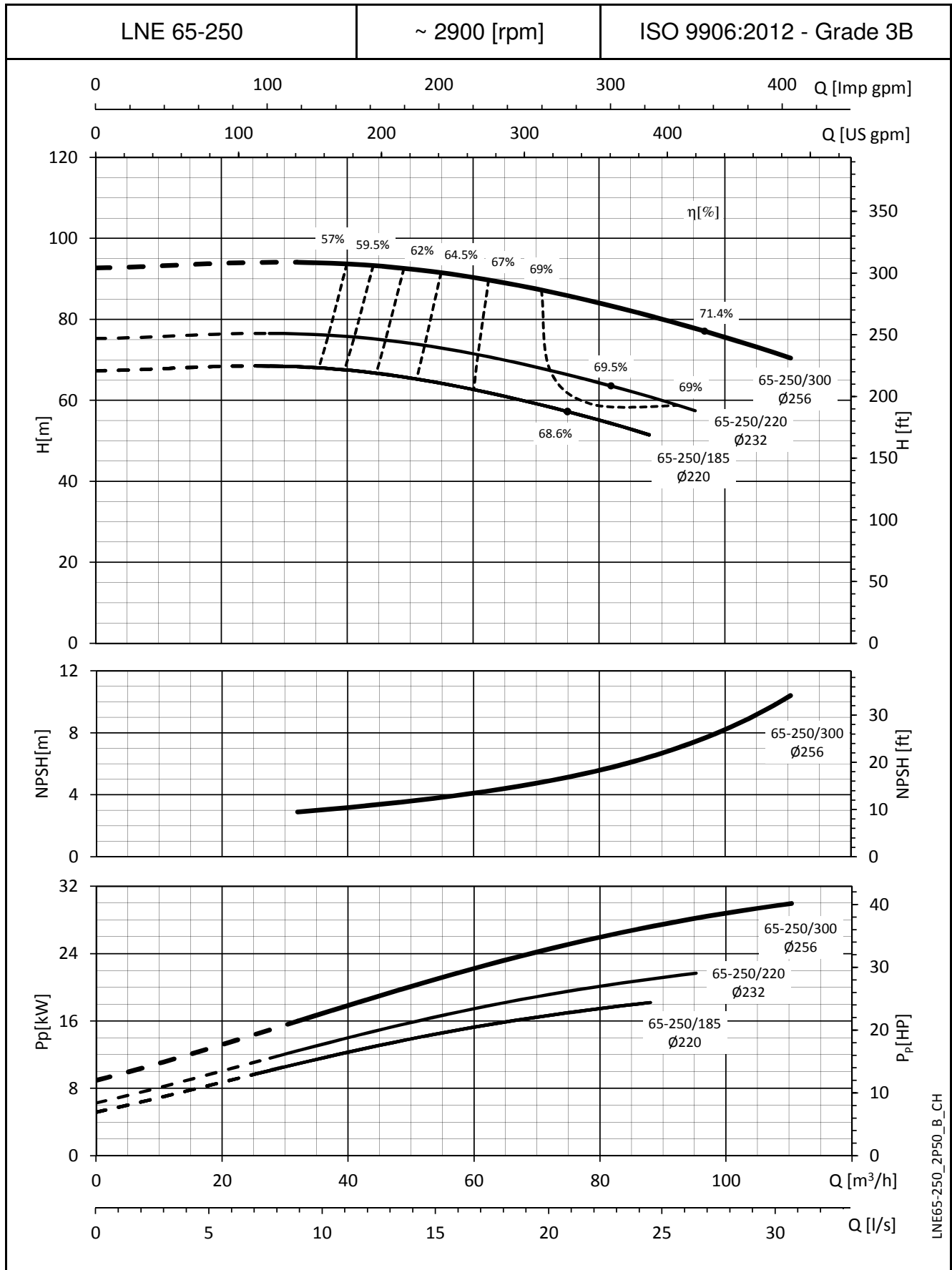

The NPSH values are laboratory values; for practical use we suggest increasing these values by 0,5 m.
 These performances are valid for liquids with density $\rho = 1,0 \text{ Kg/dm}^3$ and kinematic viscosity $\nu = 1 \text{ mm}^2/\text{sec}$.

e-LNE SERIES

OPERATING CHARACTERISTICS AT 50 Hz, 2 POLES

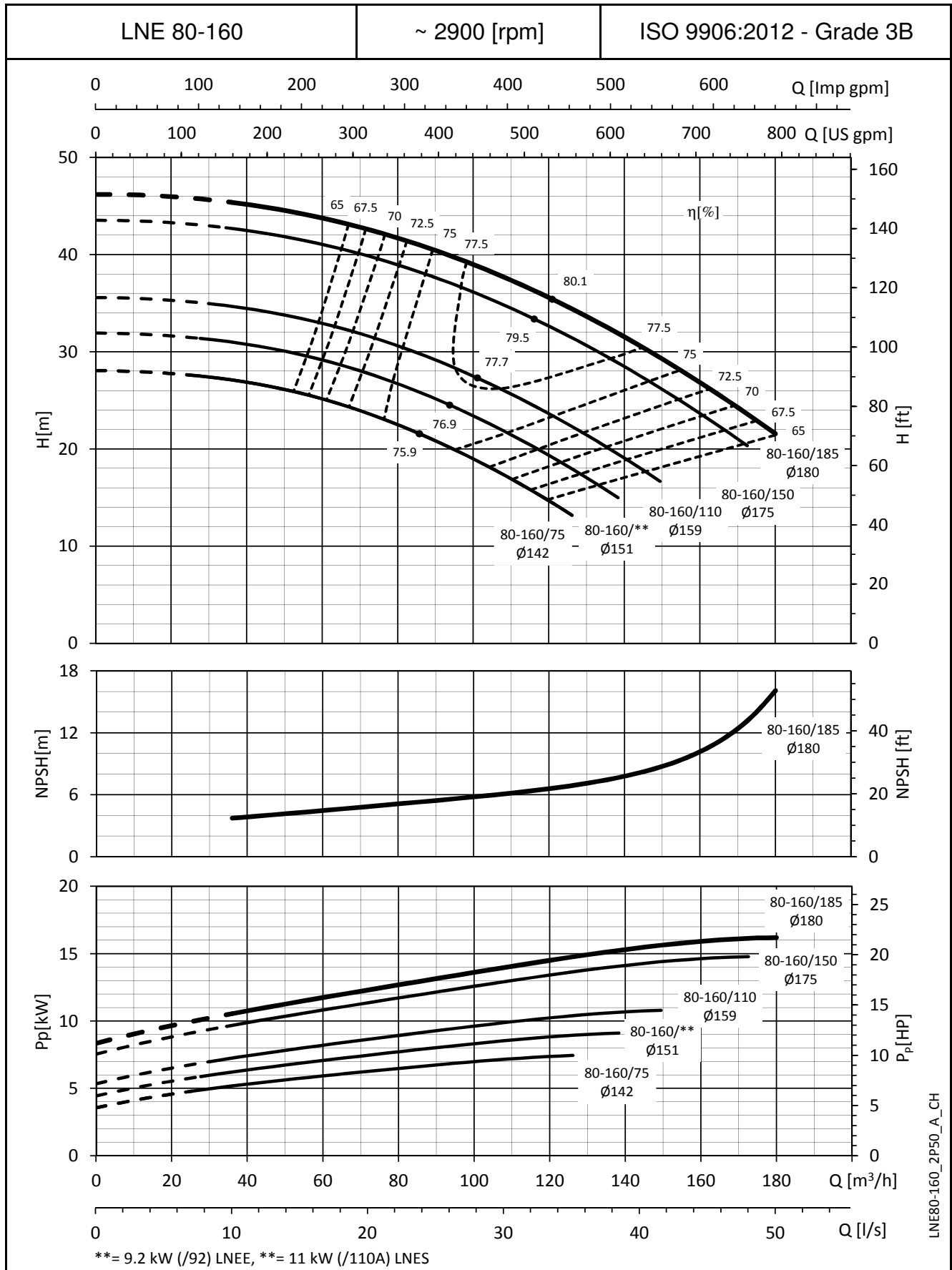

The NPSH values are laboratory values; for practical use we suggest increasing these values by 0,5 m.
 These performances are valid for liquids with density $\rho = 1,0 \text{ Kg/dm}^3$ and kinematic viscosity $\nu = 1 \text{ mm}^2/\text{sec}$.

e-LNE SERIES

OPERATING CHARACTERISTICS AT 50 Hz, 2 POLES

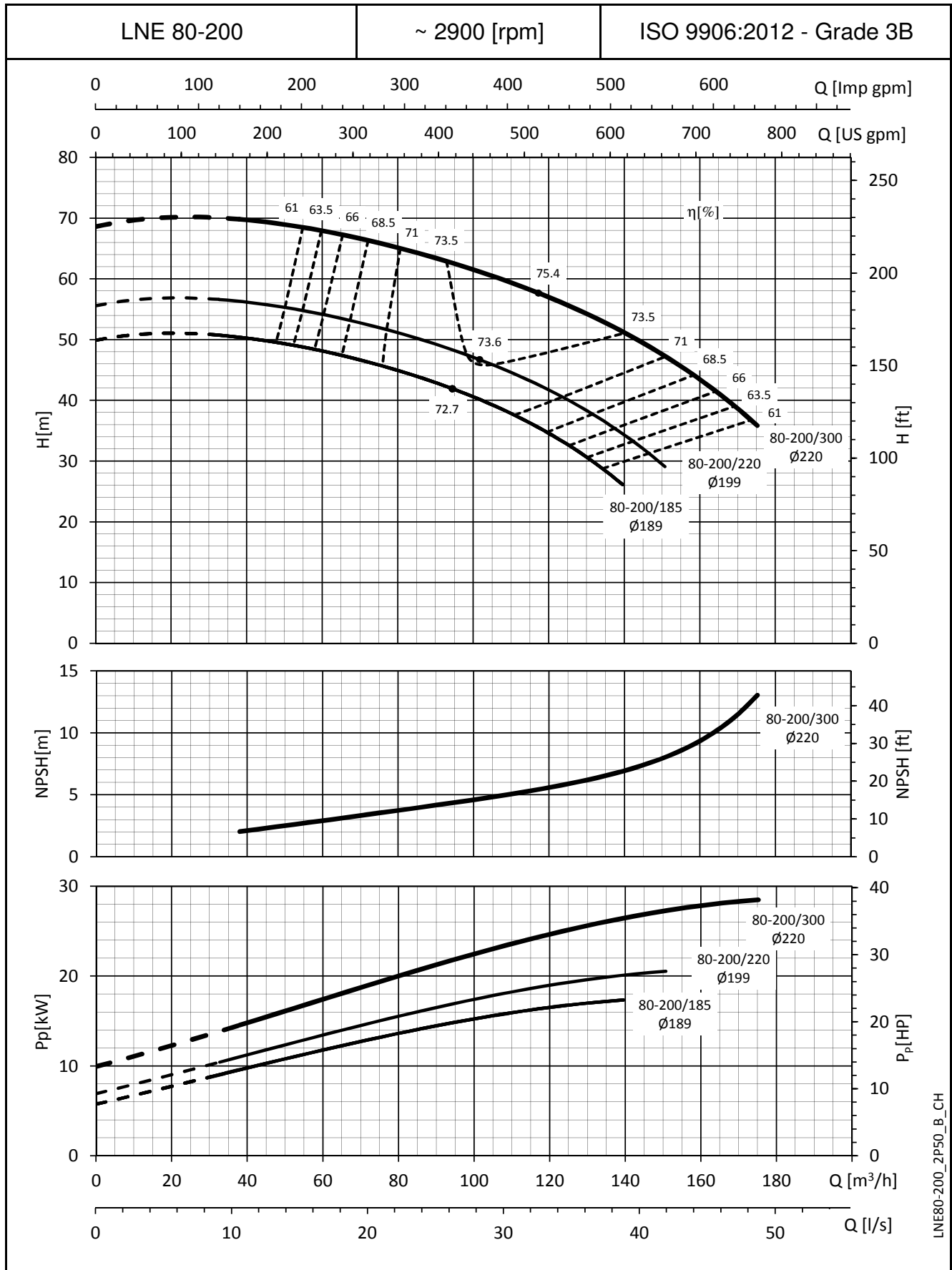

The NPSH values are laboratory values; for practical use we suggest increasing these values by 0,5 m.
 These performances are valid for liquids with density $\rho = 1,0 \text{ Kg/dm}^3$ and kinematic viscosity $\nu = 1 \text{ mm}^2/\text{sec}$.

e-LNE SERIES
OPERATING CHARACTERISTICS AT 50 Hz, 2 POLES

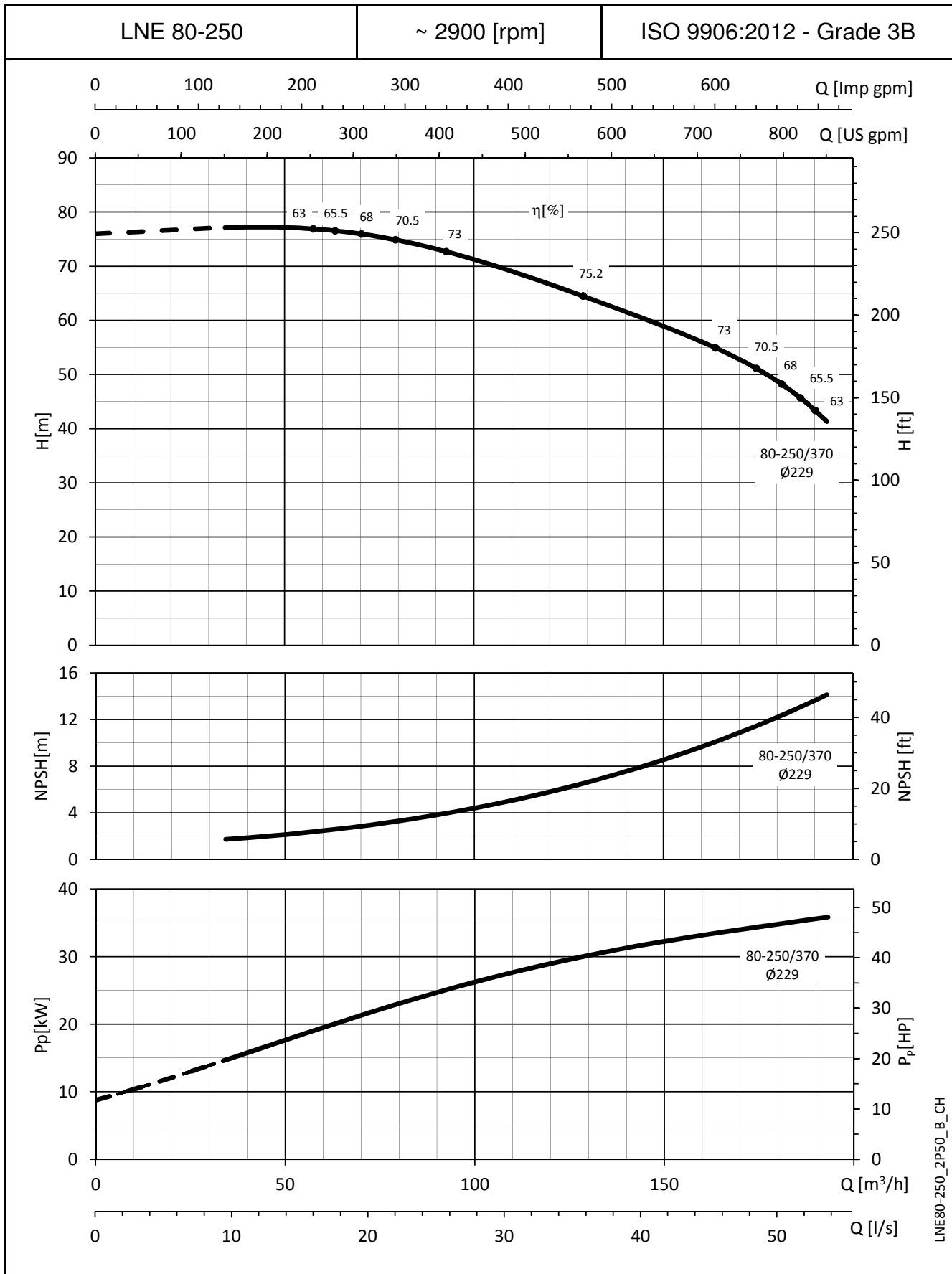

The NPSH values are laboratory values; for practical use we suggest increasing these values by 0,5 m.
 These performances are valid for liquids with density $\rho = 1,0 \text{ Kg/dm}^3$ and kinematic viscosity $\nu = 1 \text{ mm}^2/\text{sec}$.

e-LNE SERIES

OPERATING CHARACTERISTICS AT 50 Hz, 2 POLES

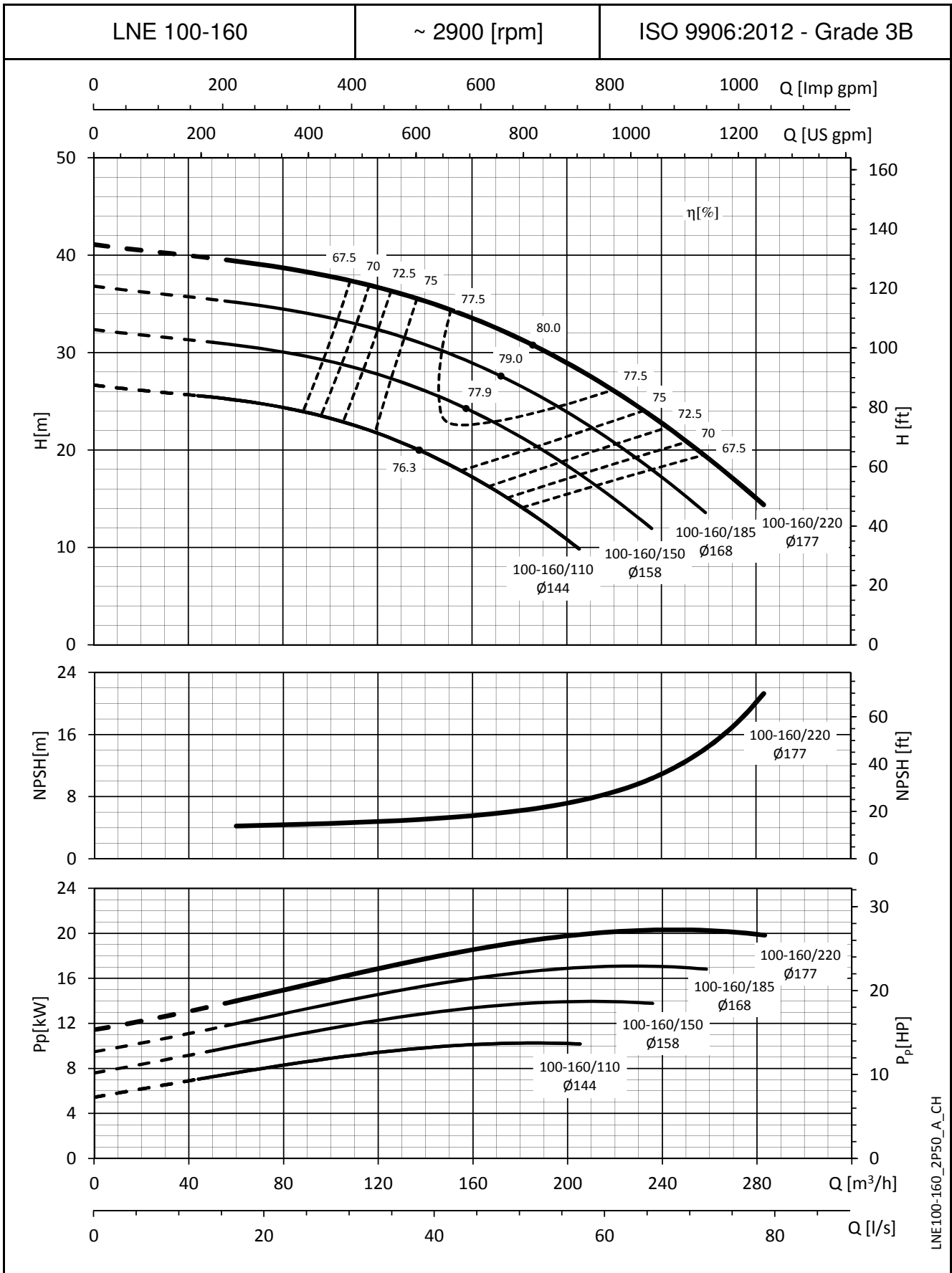

LNE100-160_2P50_A_CH

The NPSH values are laboratory values; for practical use we suggest increasing these values by 0,5 m.
 These performances are valid for liquids with density $\rho = 1,0 \text{ Kg/dm}^3$ and kinematic viscosity $\nu = 1 \text{ mm}^2/\text{sec}$.

e-LNE SERIES

OPERATING CHARACTERISTICS AT 50 Hz, 2 POLES

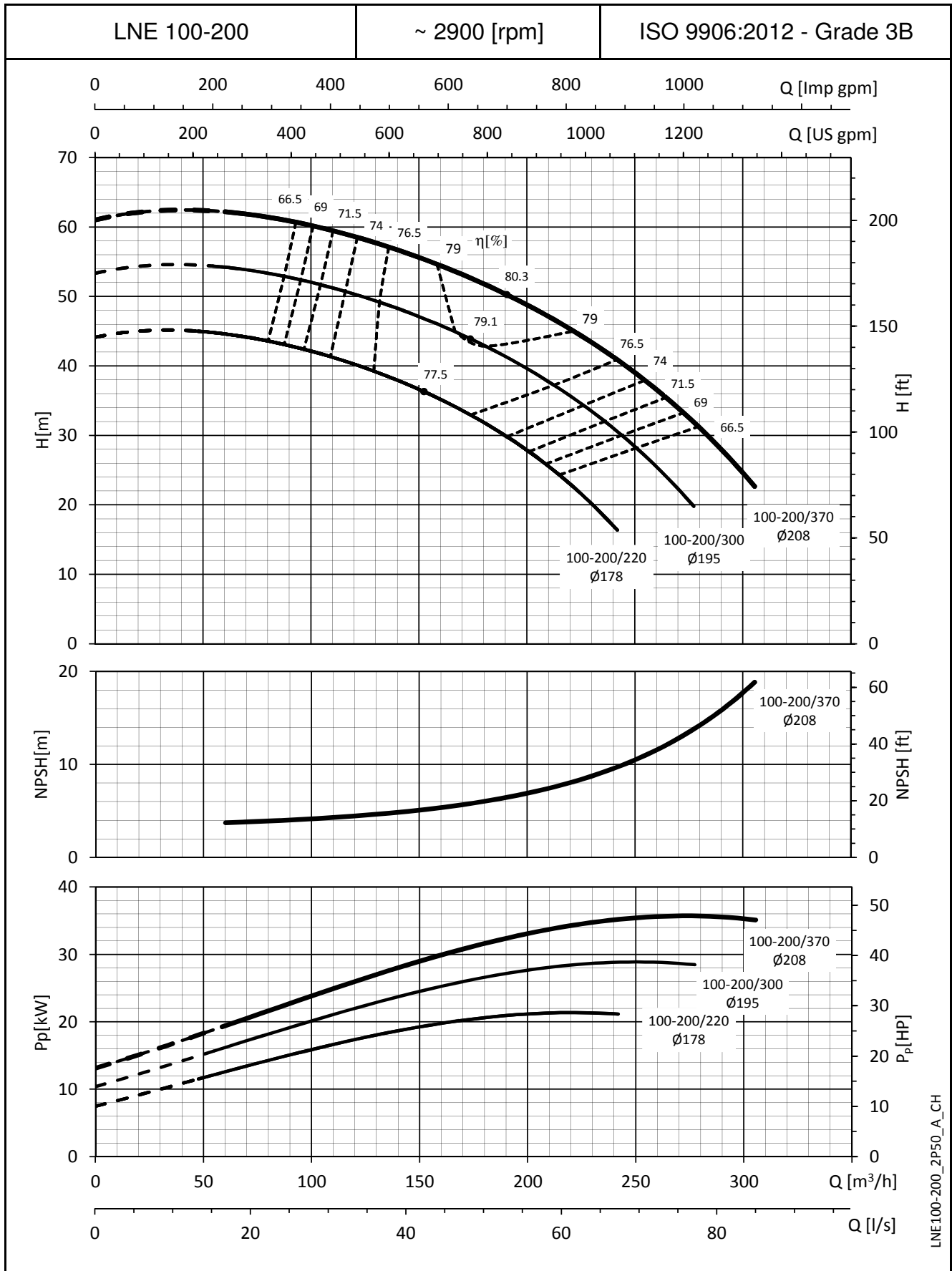

LNE100-200_2P50_A_CH

The NPSH values are laboratory values; for practical use we suggest increasing these values by 0,5 m.
 These performances are valid for liquids with density $\rho = 1,0 \text{ Kg/dm}^3$ and kinematic viscosity $\nu = 1 \text{ mm}^2/\text{sec}$.

e-LNE SERIES
OPERATING CHARACTERISTICS AT 50 Hz, 2 POLES

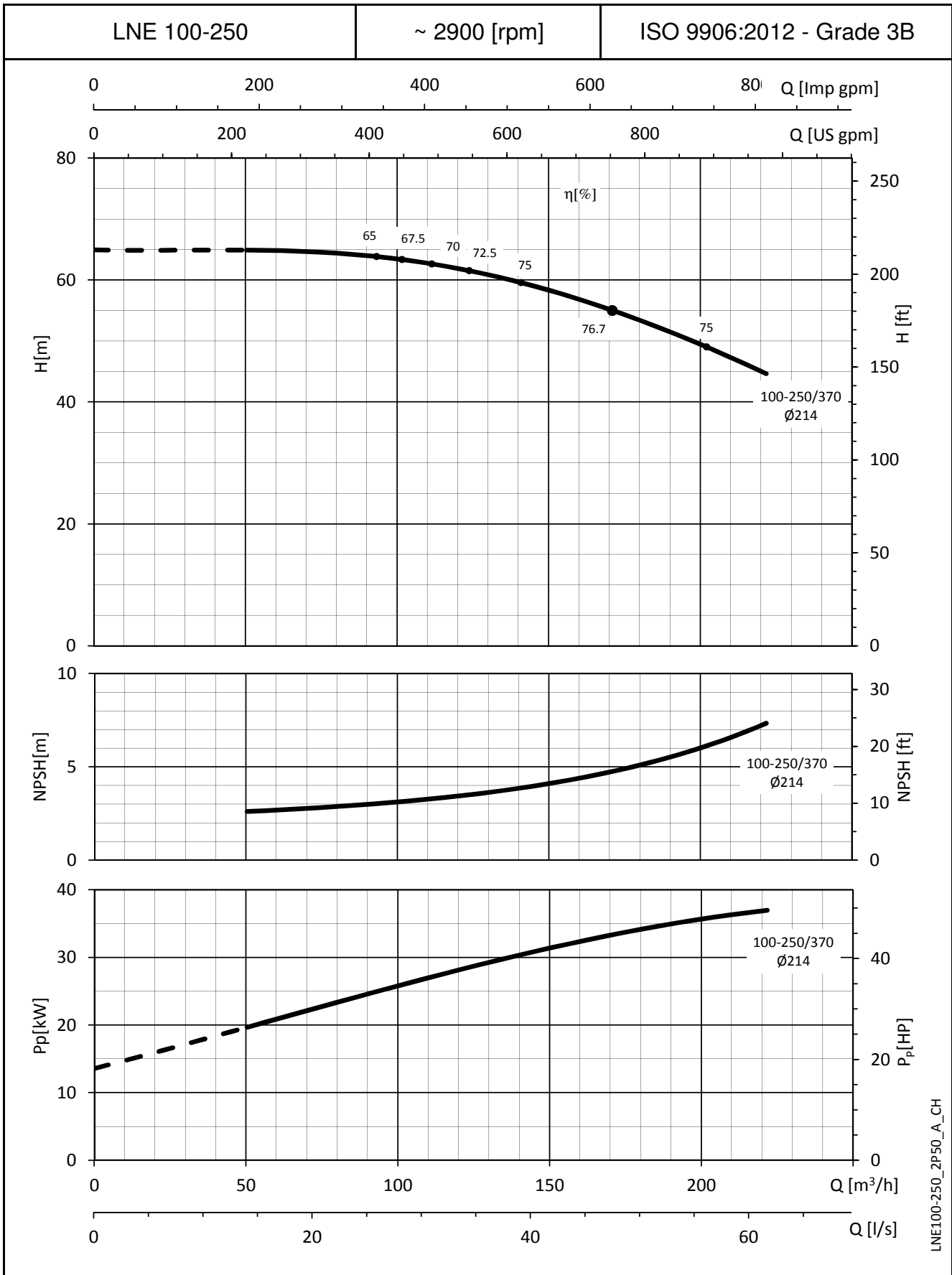

The NPSH values are laboratory values; for practical use we suggest increasing these values by 0,5 m.
 These performances are valid for liquids with density $\rho = 1,0 \text{ Kg/dm}^3$ and kinematic viscosity $\nu = 1 \text{ mm}^2/\text{sec}$.

e-LNE SERIES

OPERATING CHARACTERISTICS AT 50 Hz, 4 POLES

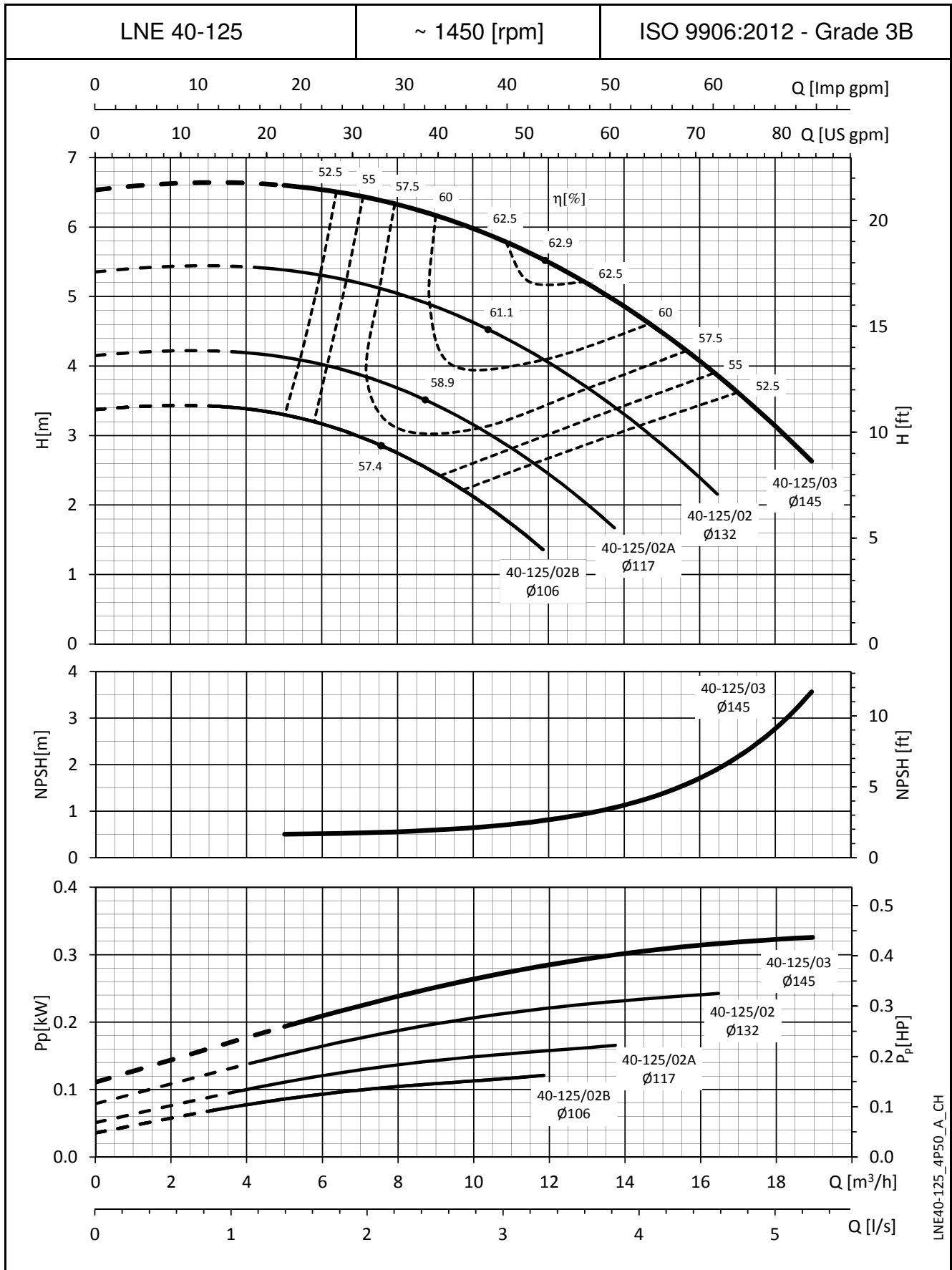

The NPSH values are laboratory values; for practical use we suggest increasing these values by 0,5 m.
 These performances are valid for liquids with density $\rho = 1,0 \text{ Kg/dm}^3$ and kinematic viscosity $\nu = 1 \text{ mm}^2/\text{sec}$.

e-LNE SERIES

OPERATING CHARACTERISTICS AT 50 Hz, 4 POLES

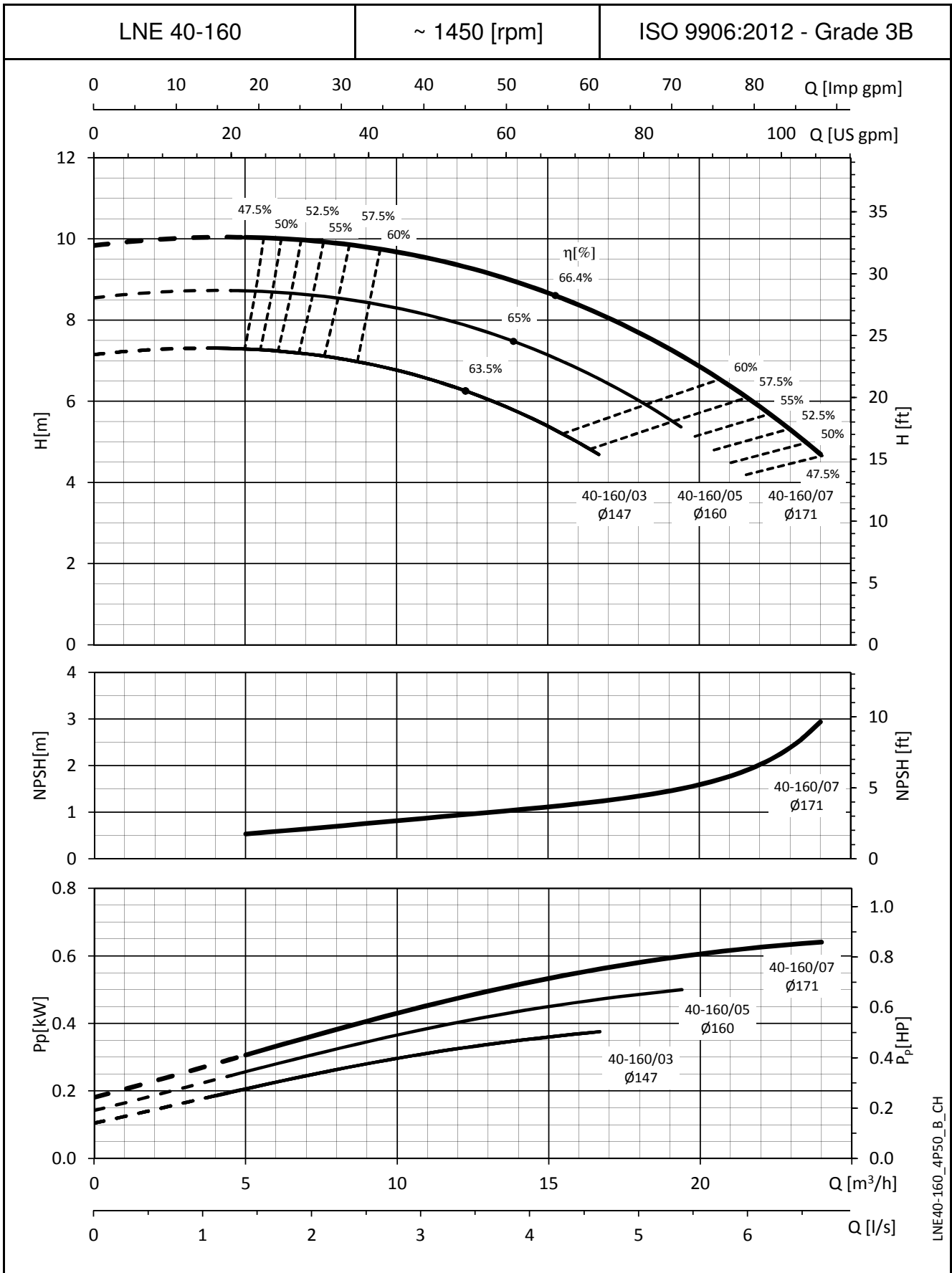

The NPSH values are laboratory values; for practical use we suggest increasing these values by 0,5 m.
 These performances are valid for liquids with density $\rho = 1,0 \text{ Kg/dm}^3$ and kinematic viscosity $\nu = 1 \text{ mm}^2/\text{sec}$.

e-LNE SERIES

OPERATING CHARACTERISTICS AT 50 Hz, 4 POLES

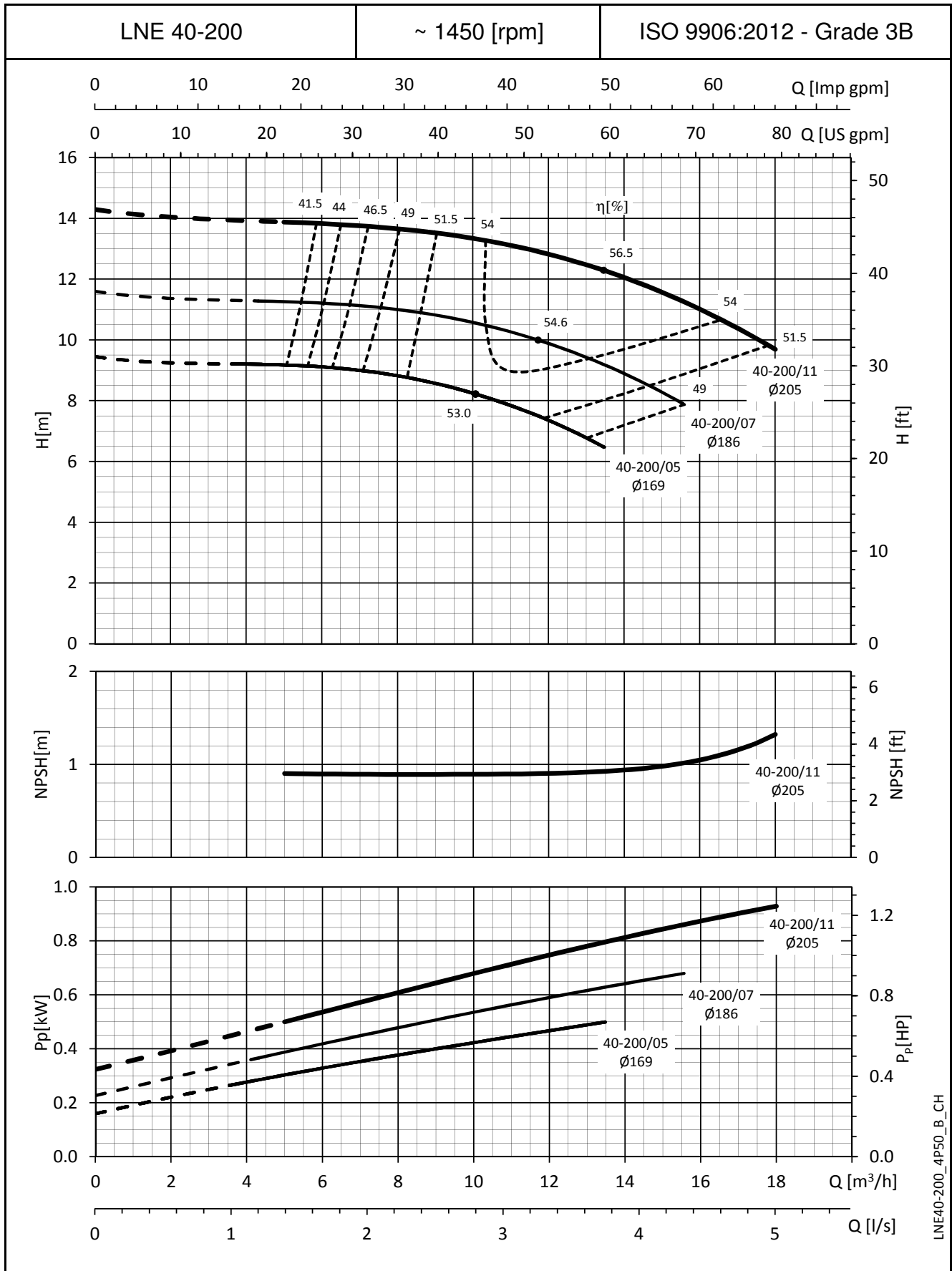

The NPSH values are laboratory values; for practical use we suggest increasing these values by 0,5 m.
 These performances are valid for liquids with density $\rho = 1,0 \text{ Kg/dm}^3$ and kinematic viscosity $\nu = 1 \text{ mm}^2/\text{sec}$.

e-LNE SERIES

OPERATING CHARACTERISTICS AT 50 Hz, 4 POLES

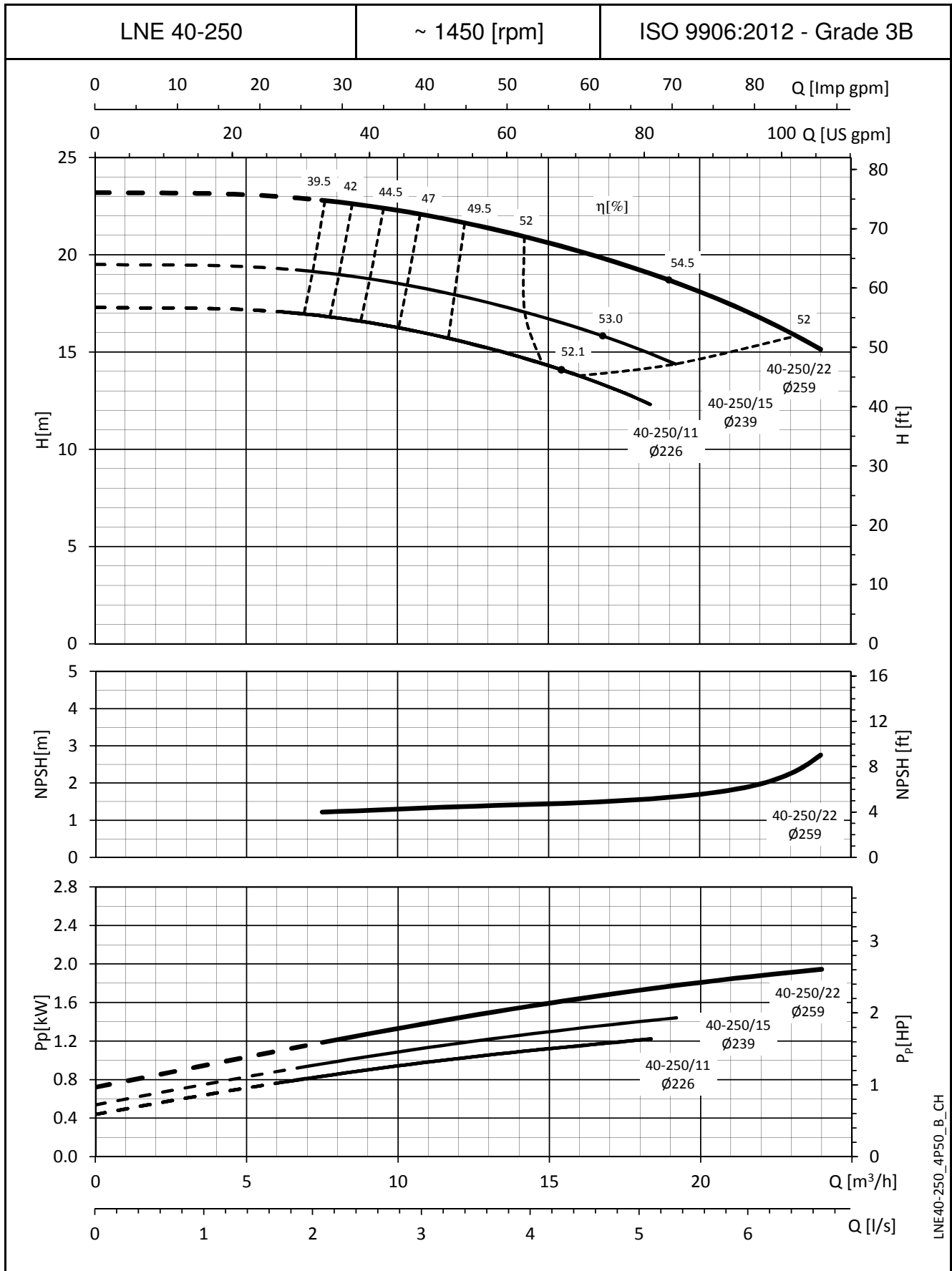

LNE40-250_4P50_B_CH

The NPSH values are laboratory values; for practical use we suggest increasing these values by 0,5 m.
 These performances are valid for liquids with density $\rho = 1,0 \text{ Kg/dm}^3$ and kinematic viscosity $\nu = 1 \text{ mm}^2/\text{sec}$.

e-LNE SERIES

OPERATING CHARACTERISTICS AT 50 Hz, 4 POLES

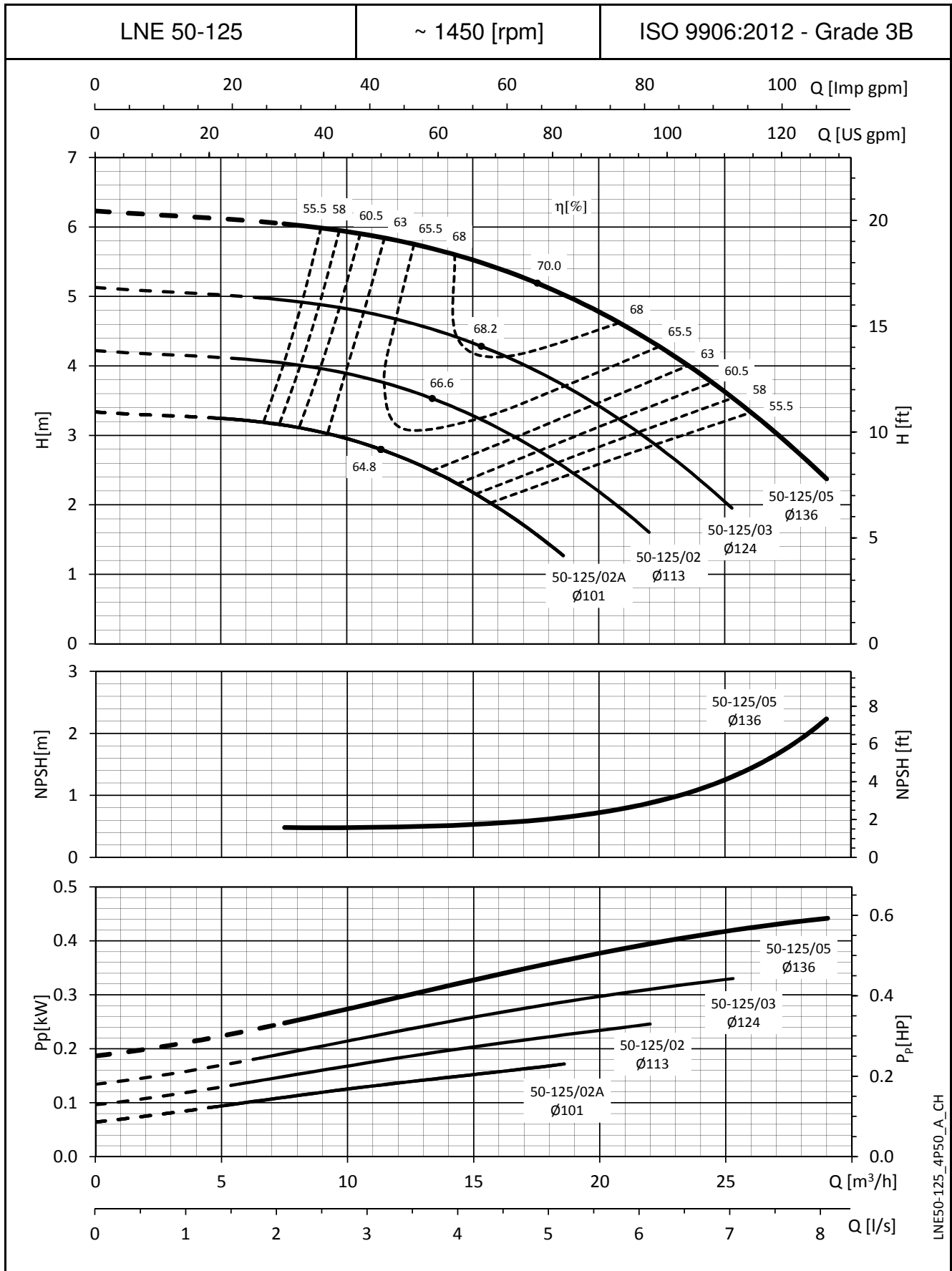

The NPSH values are laboratory values; for practical use we suggest increasing these values by 0,5 m.
 These performances are valid for liquids with density $\rho = 1,0 \text{ Kg/dm}^3$ and kinematic viscosity $\nu = 1 \text{ mm}^2/\text{sec}$.

e-LNE SERIES

OPERATING CHARACTERISTICS AT 50 Hz, 4 POLES

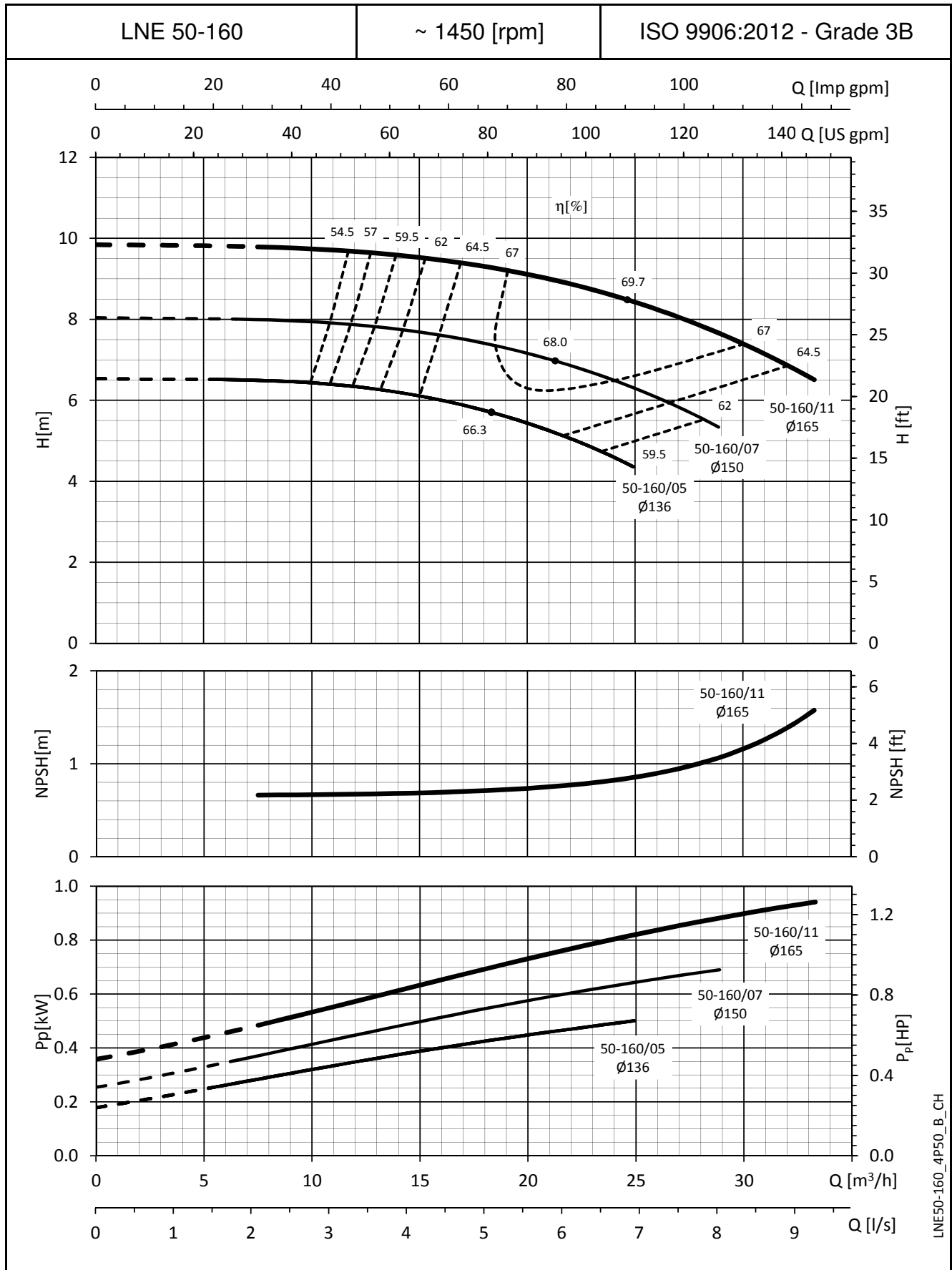

The NPSH values are laboratory values; for practical use we suggest increasing these values by 0,5 m.
 These performances are valid for liquids with density $\rho = 1,0 \text{ Kg/dm}^3$ and kinematic viscosity $\nu = 1 \text{ mm}^2/\text{sec}$.

e-LNE SERIES

OPERATING CHARACTERISTICS AT 50 Hz, 4 POLES

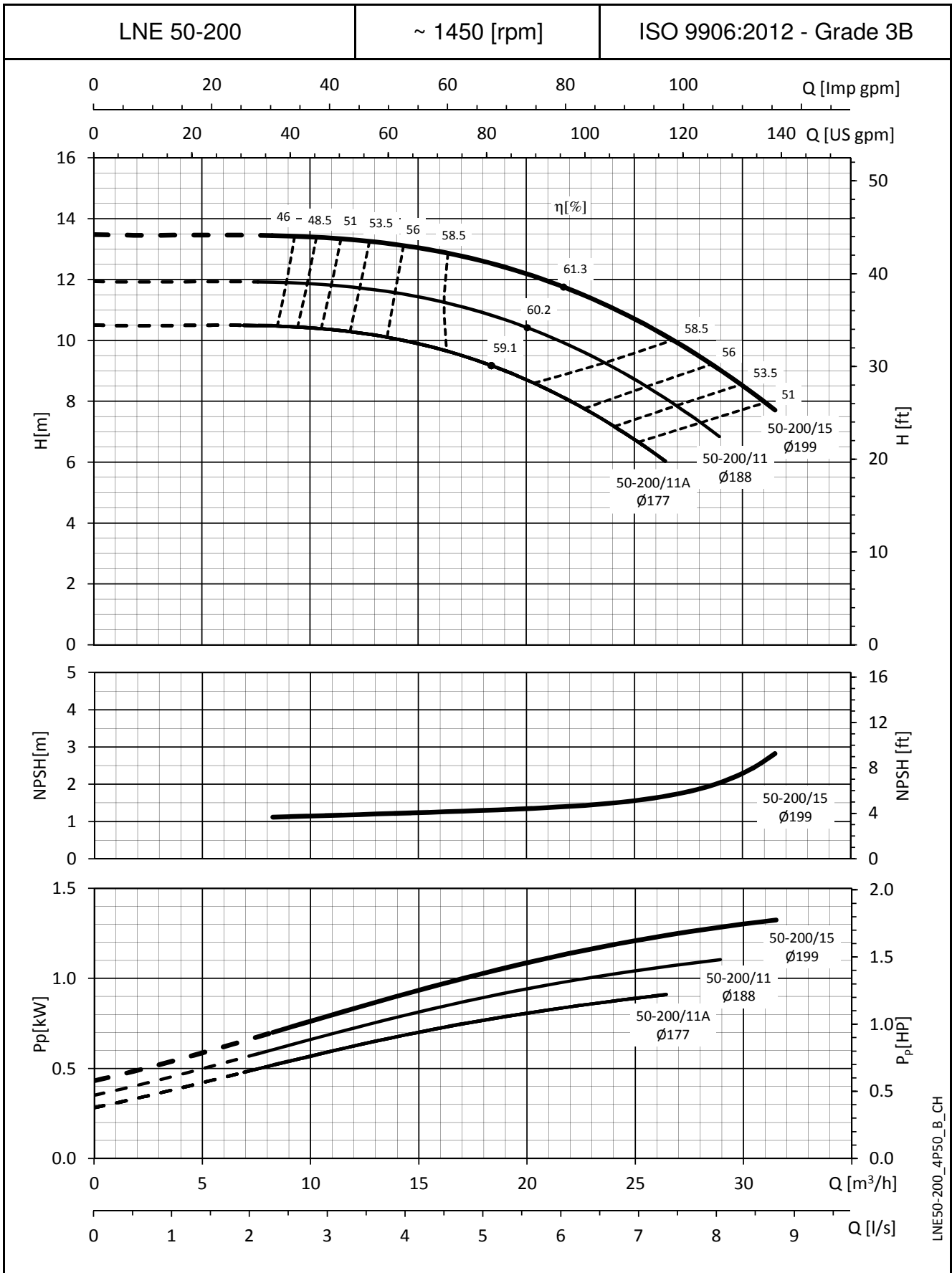

LNE50-200_4P50_B_CH

The NPSH values are laboratory values; for practical use we suggest increasing these values by 0,5 m.
 These performances are valid for liquids with density $\rho = 1,0 \text{ Kg/dm}^3$ and kinematic viscosity $\nu = 1 \text{ mm}^2/\text{sec}$.

e-LNE SERIES

OPERATING CHARACTERISTICS AT 50 Hz, 4 POLES

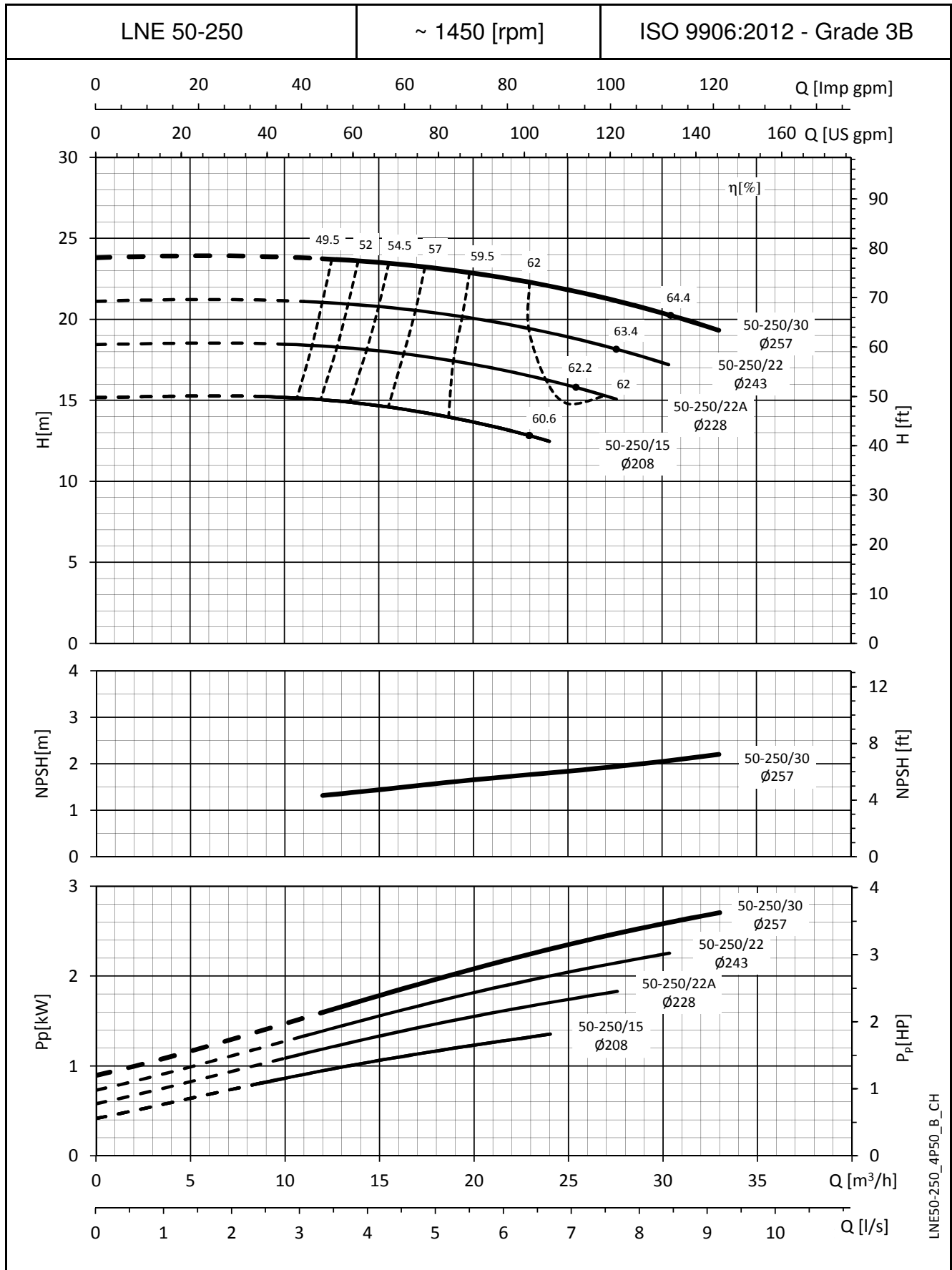

The NPSH values are laboratory values; for practical use we suggest increasing these values by 0,5 m.
 These performances are valid for liquids with density $\rho = 1,0 \text{ Kg/dm}^3$ and kinematic viscosity $\nu = 1 \text{ mm}^2/\text{sec}$.

e-LNE SERIES

OPERATING CHARACTERISTICS AT 50 Hz, 4 POLES

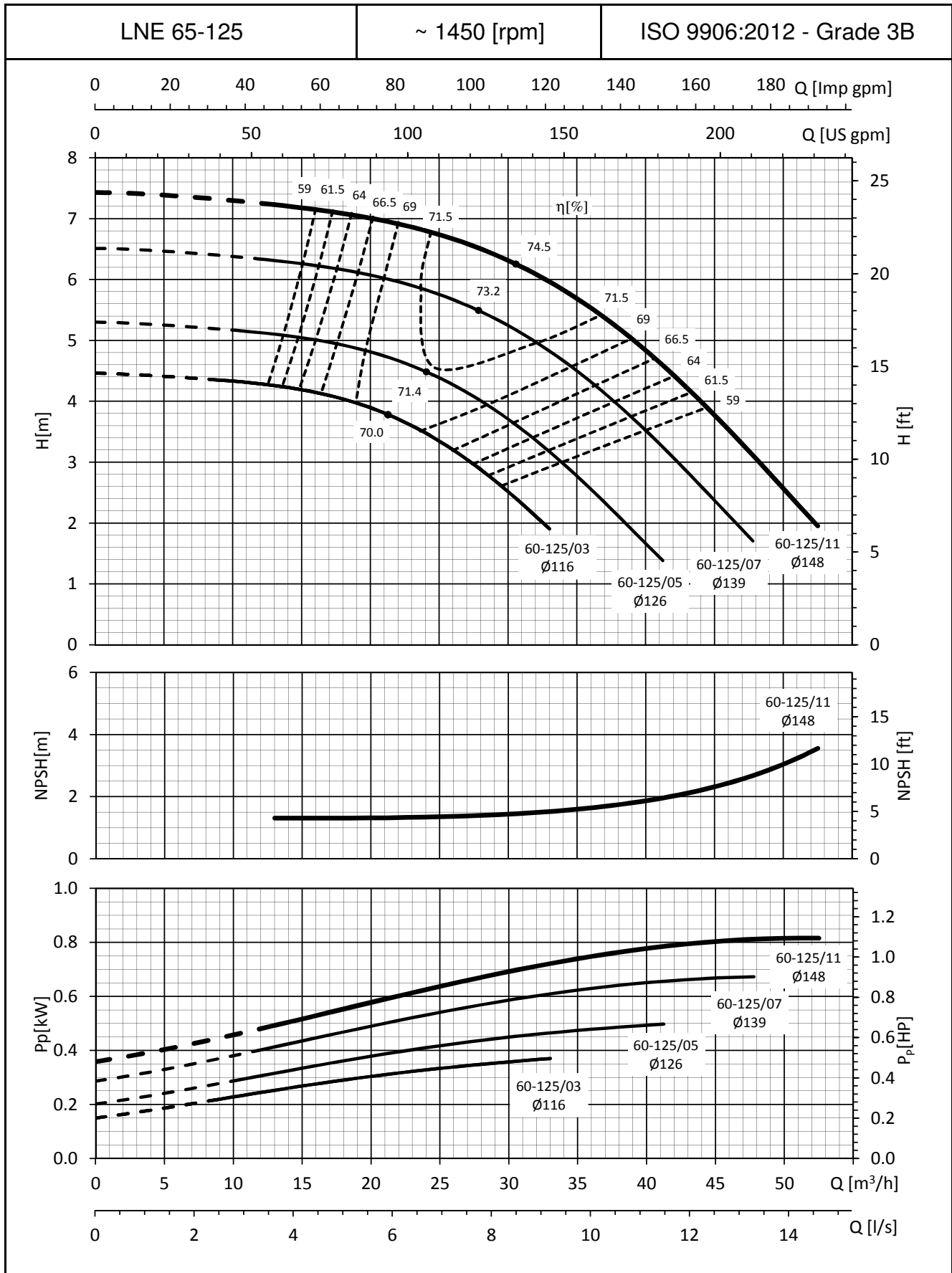

The NPSH values are laboratory values; for practical use we suggest increasing these values by 0,5 m.
 These performances are valid for liquids with density $\rho = 1,0 \text{ Kg/dm}^3$ and kinematic viscosity $\nu = 1 \text{ mm}^2/\text{sec}$.

e-LNE SERIES

OPERATING CHARACTERISTICS AT 50 Hz, 4 POLES

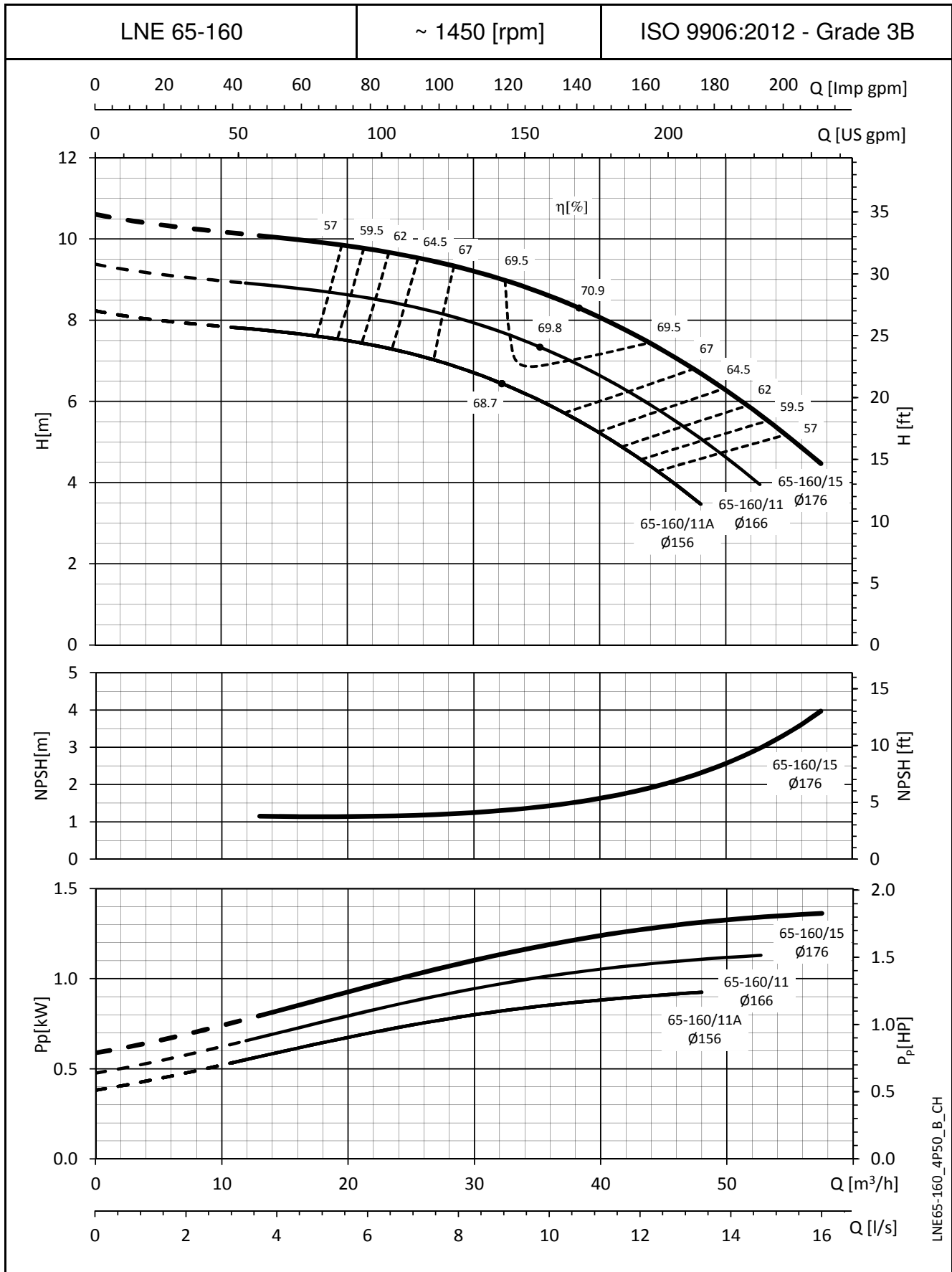

The NPSH values are laboratory values; for practical use we suggest increasing these values by 0,5 m.
 These performances are valid for liquids with density $\rho = 1,0 \text{ Kg/dm}^3$ and kinematic viscosity $\nu = 1 \text{ mm}^2/\text{sec}$.

e-LNE SERIES

OPERATING CHARACTERISTICS AT 50 Hz, 4 POLES

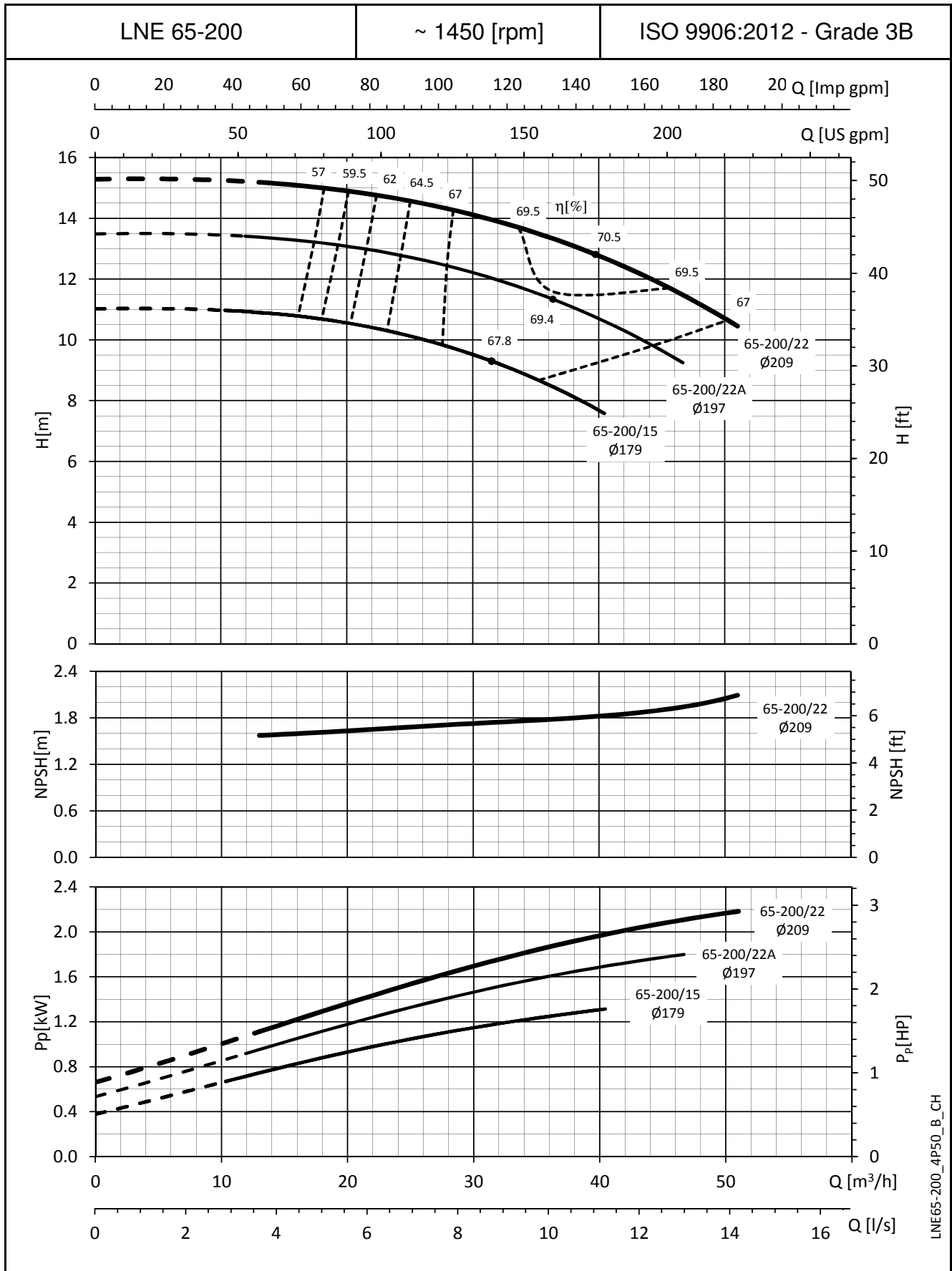

The NPSH values are laboratory values; for practical use we suggest increasing these values by 0,5 m.
 These performances are valid for liquids with density $\rho = 1,0 \text{ Kg/dm}^3$ and kinematic viscosity $\nu = 1 \text{ mm}^2/\text{sec}$.

e-LNE SERIES

OPERATING CHARACTERISTICS AT 50 Hz, 4 POLES

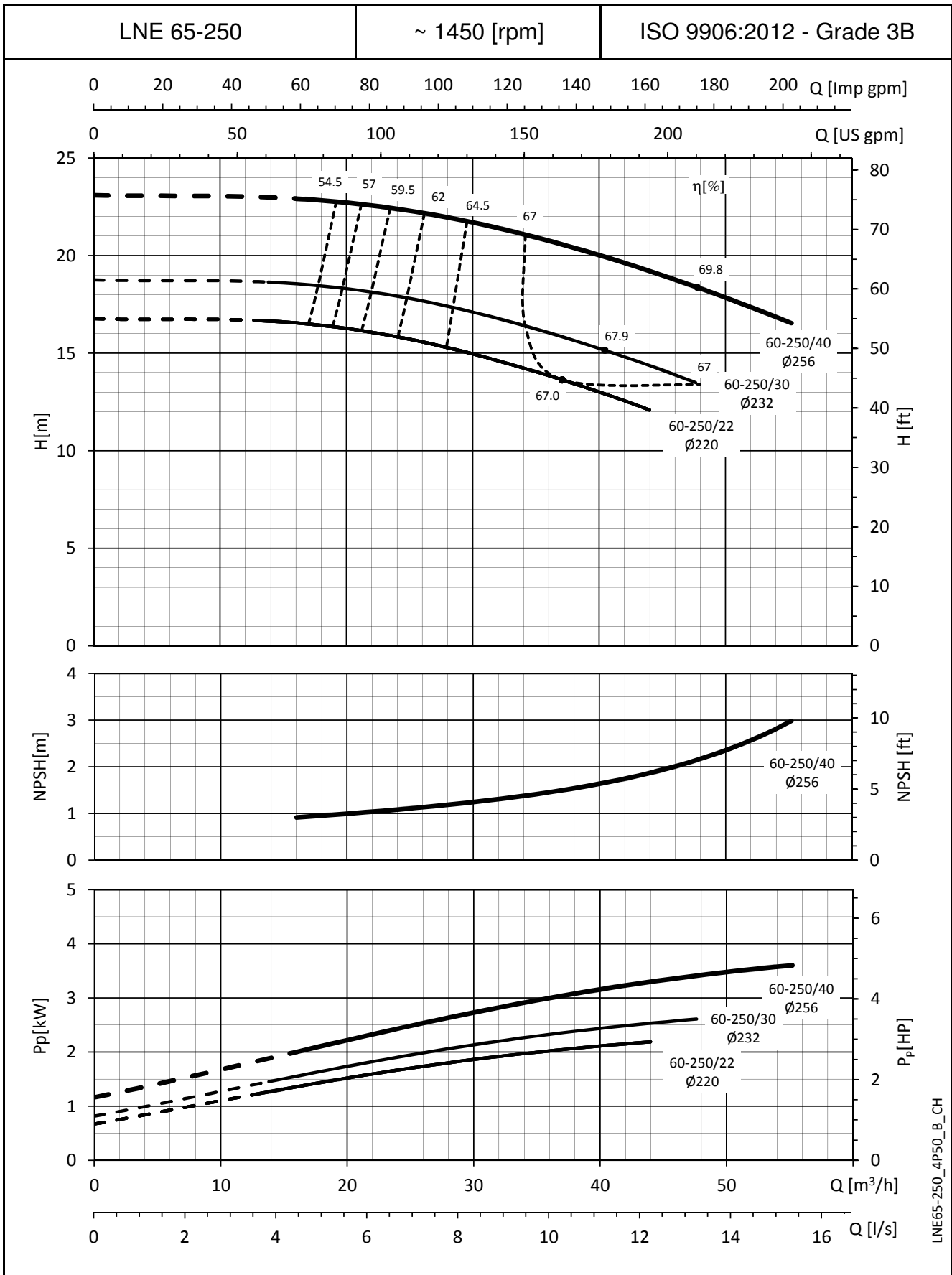

LNE65-250_4P50_B_CH

The NPSH values are laboratory values; for practical use we suggest increasing these values by 0,5 m.
 These performances are valid for liquids with density $\rho = 1,0 \text{ Kg/dm}^3$ and kinematic viscosity $\nu = 1 \text{ mm}^2/\text{sec}$.

e-LNE SERIES

OPERATING CHARACTERISTICS AT 50 Hz, 4 POLES

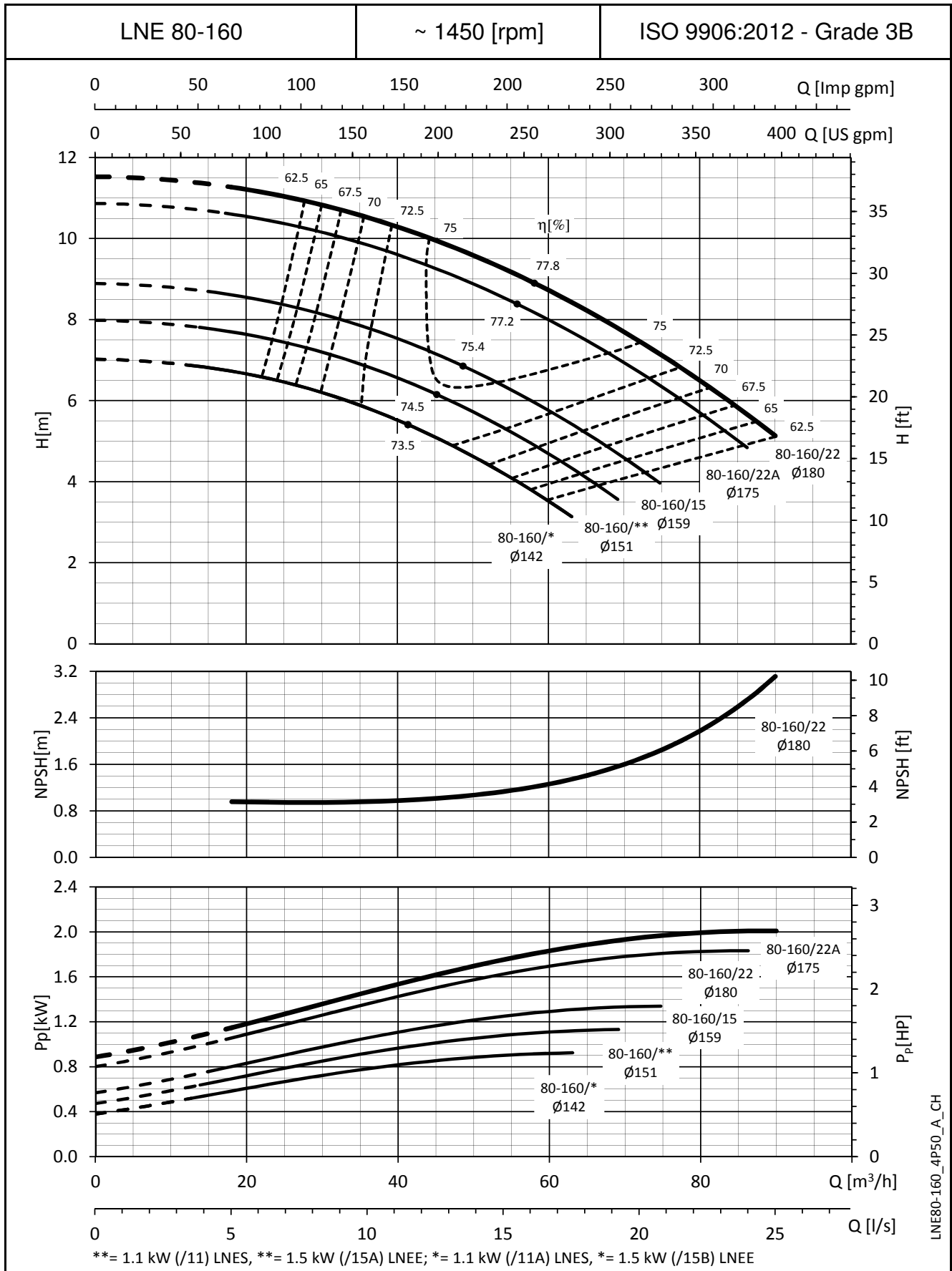

LNE80-160_4P50_A_CH

The NPSH values are laboratory values; for practical use we suggest increasing these values by 0,5 m.
 These performances are valid for liquids with density $\rho = 1,0 \text{ Kg/dm}^3$ and kinematic viscosity $\nu = 1 \text{ mm}^2/\text{sec}$.

e-LNE SERIES
OPERATING CHARACTERISTICS AT 50 Hz, 4 POLES

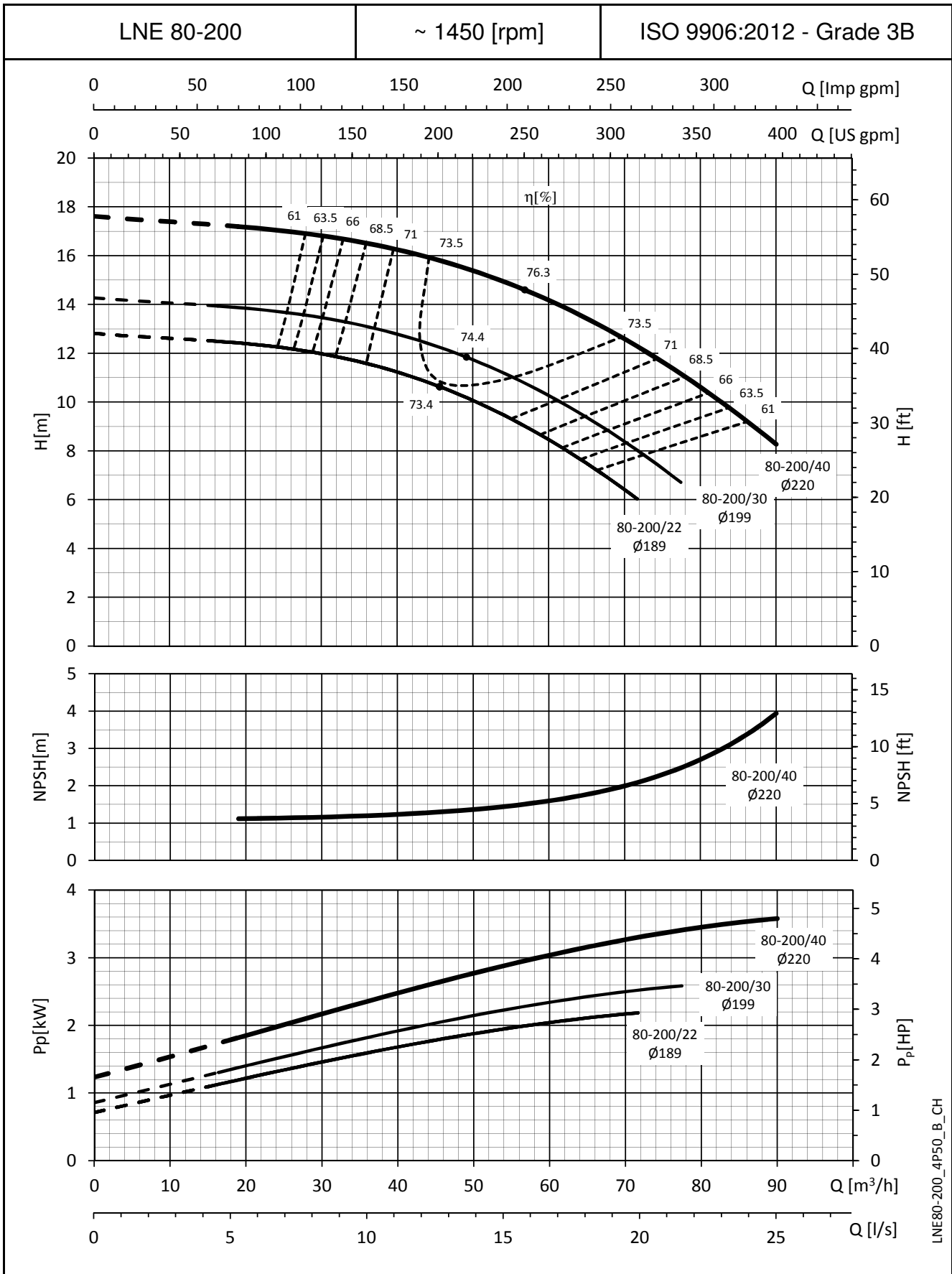

LNE80-200_4P50_B_CH

The NPSH values are laboratory values; for practical use we suggest increasing these values by 0,5 m.
 These performances are valid for liquids with density $\rho = 1,0 \text{ Kg/dm}^3$ and kinematic viscosity $\nu = 1 \text{ mm}^2/\text{sec}$.

e-LNE SERIES

OPERATING CHARACTERISTICS AT 50 Hz, 4 POLES

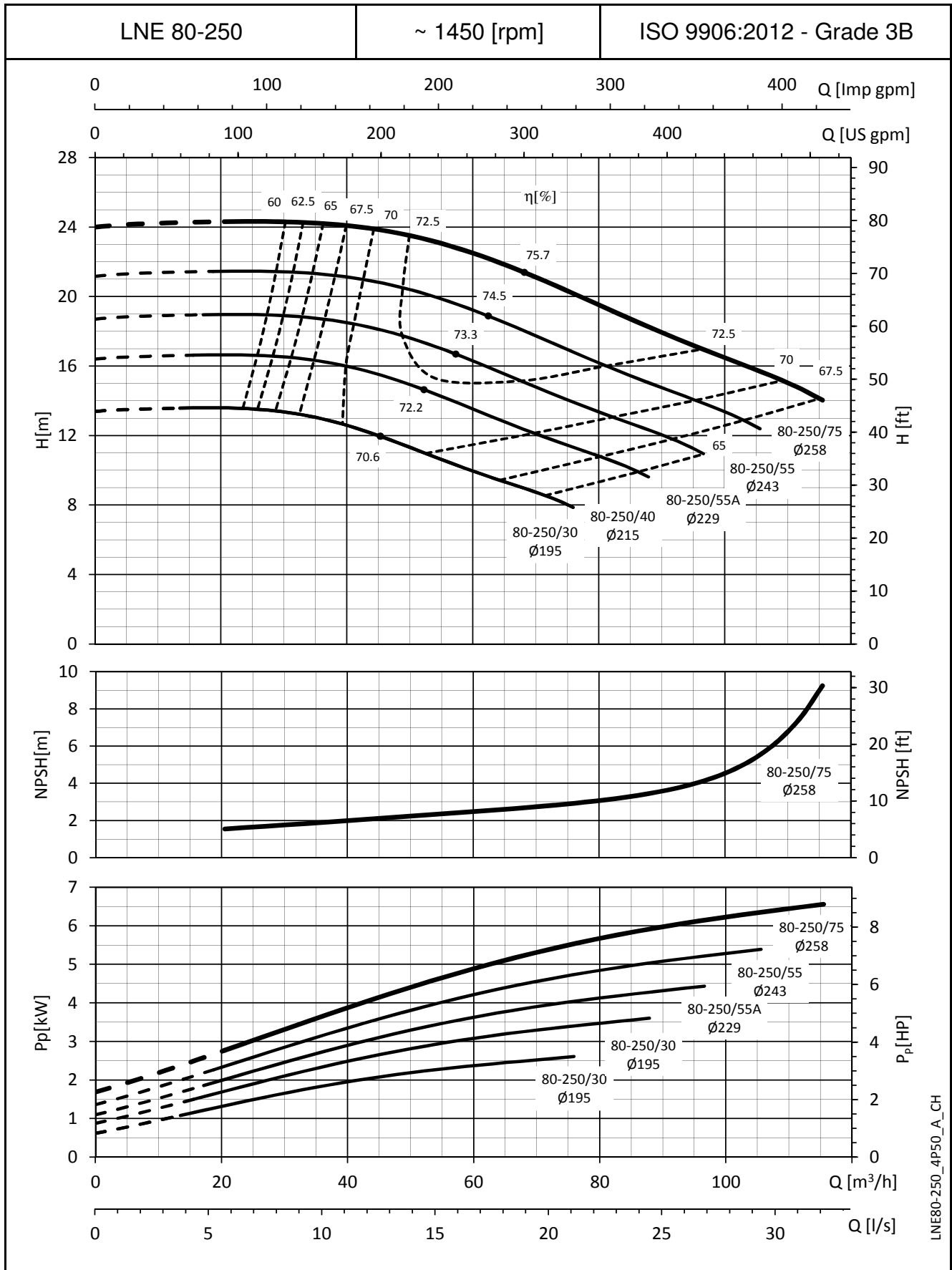

The NPSH values are laboratory values; for practical use we suggest increasing these values by 0,5 m.
 These performances are valid for liquids with density $\rho = 1,0 \text{ Kg/dm}^3$ and kinematic viscosity $\nu = 1 \text{ mm}^2/\text{sec}$.

e-LNE SERIES

OPERATING CHARACTERISTICS AT 50 Hz, 4 POLES

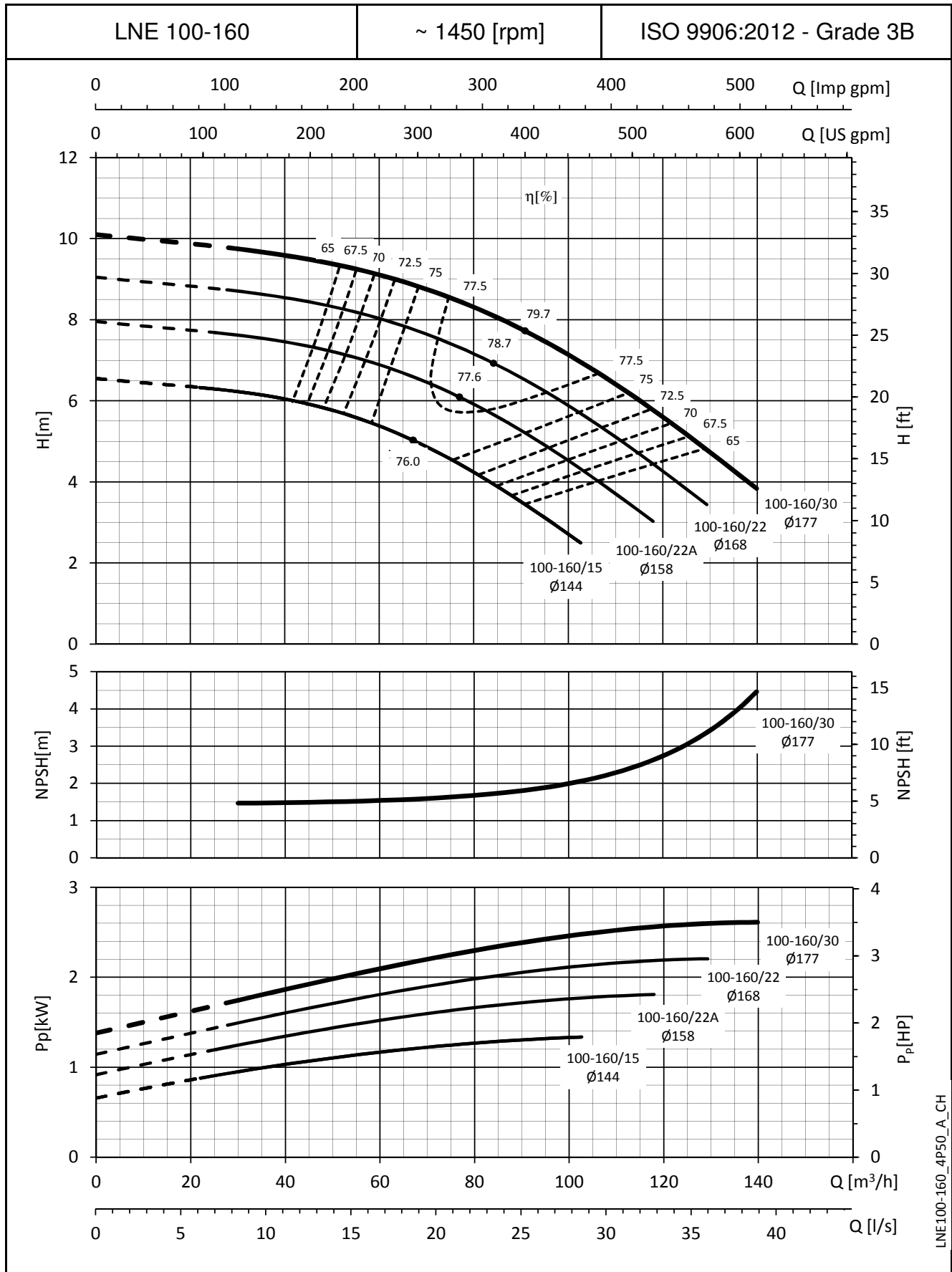

The NPSH values are laboratory values; for practical use we suggest increasing these values by 0,5 m.
 These performances are valid for liquids with density $\rho = 1,0 \text{ Kg/dm}^3$ and kinematic viscosity $\nu = 1 \text{ mm}^2/\text{sec}$.

e-LNE SERIES

OPERATING CHARACTERISTICS AT 50 Hz, 4 POLES

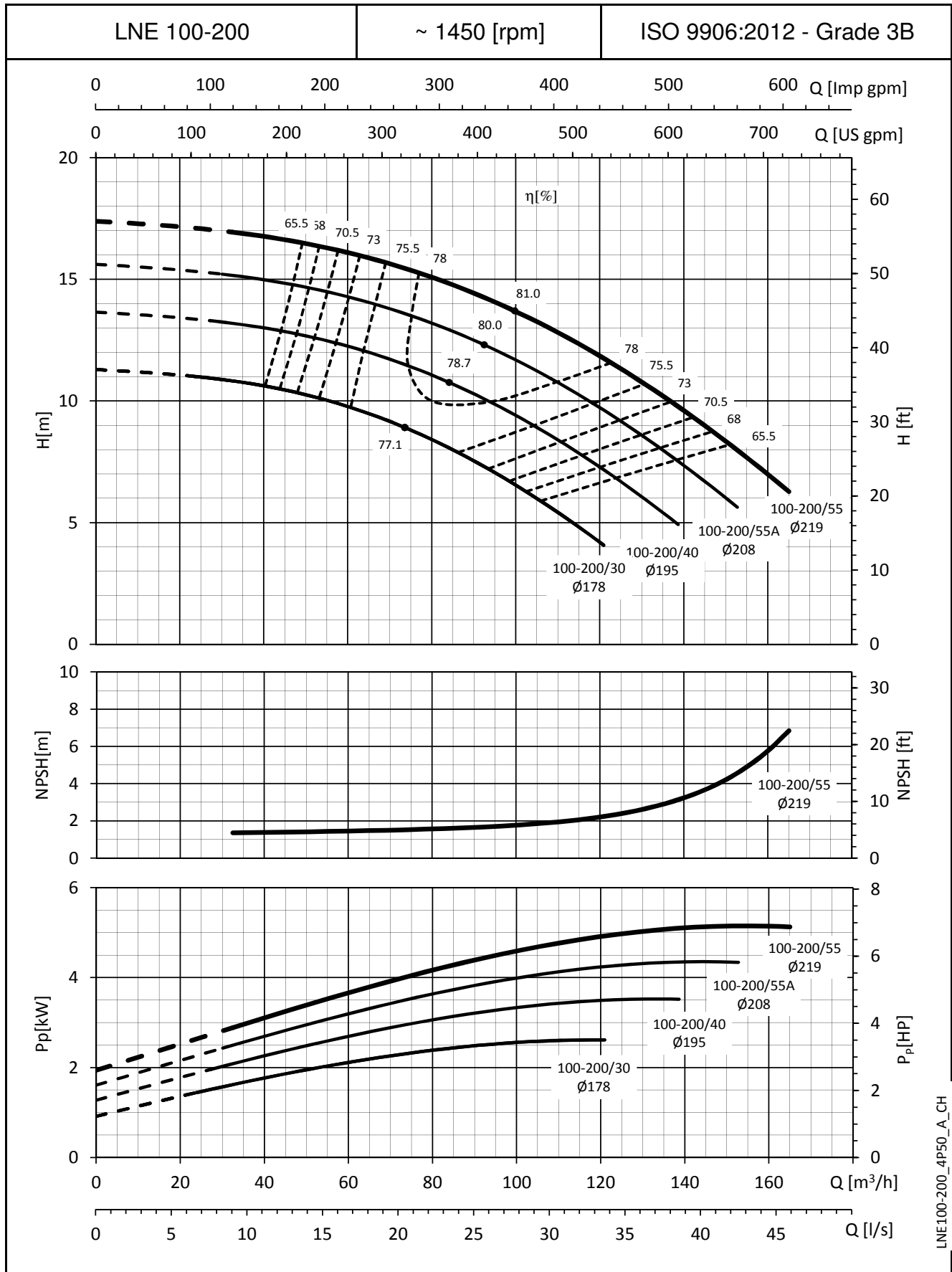

The NPSH values are laboratory values; for practical use we suggest increasing these values by 0,5 m.
 These performances are valid for liquids with density $\rho = 1,0 \text{ Kg/dm}^3$ and kinematic viscosity $\nu = 1 \text{ mm}^2/\text{sec}$.

e-LNE SERIES

OPERATING CHARACTERISTICS AT 50 Hz, 4 POLES

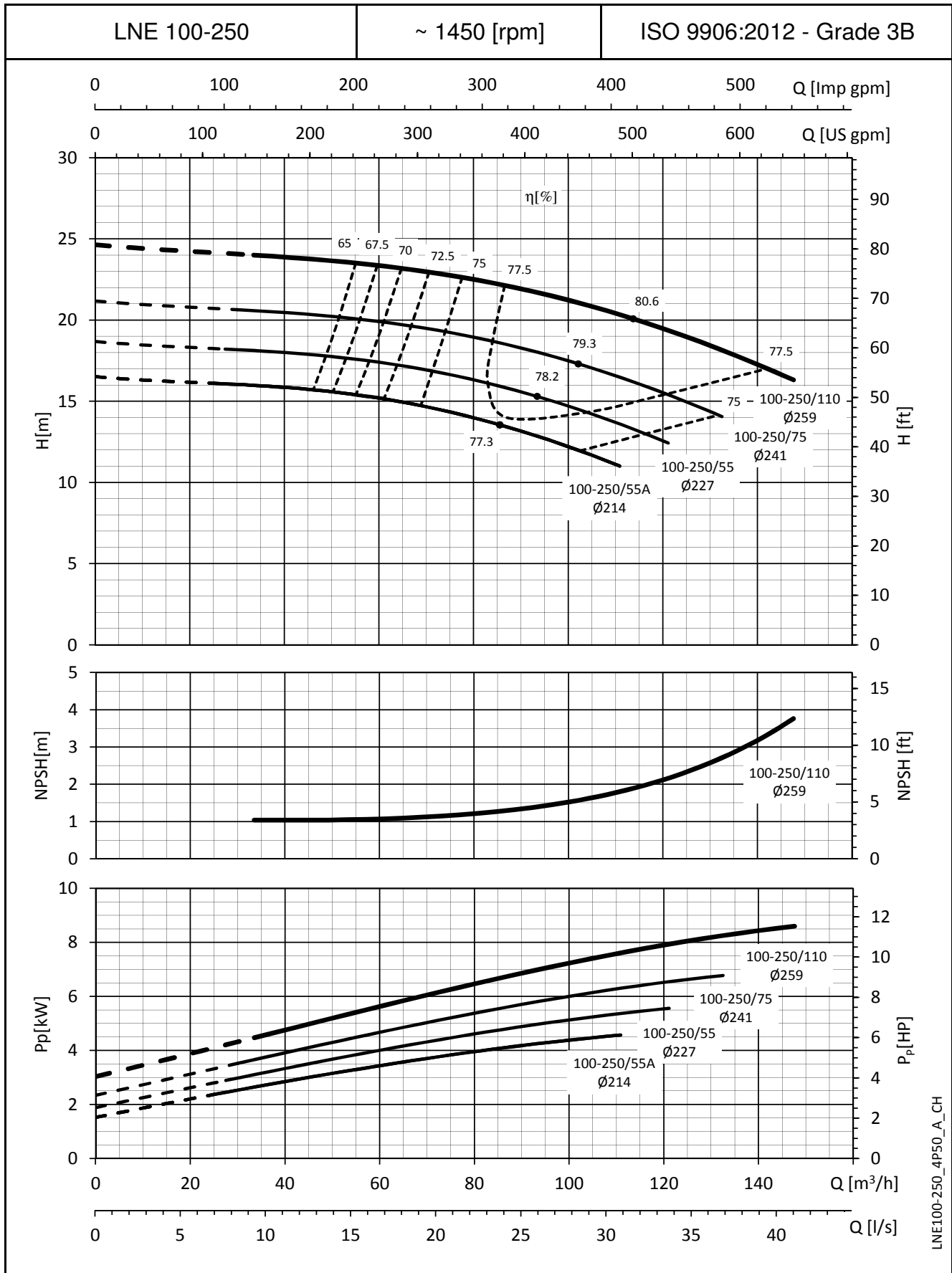

The NPSH values are laboratory values; for practical use we suggest increasing these values by 0,5 m.
 These performances are valid for liquids with density $\rho = 1,0 \text{ Kg/dm}^3$ and kinematic viscosity $\nu = 1 \text{ mm}^2/\text{sec}$.

e-LNE SERIES

OPERATING CHARACTERISTICS AT 50 Hz, 4 POLES

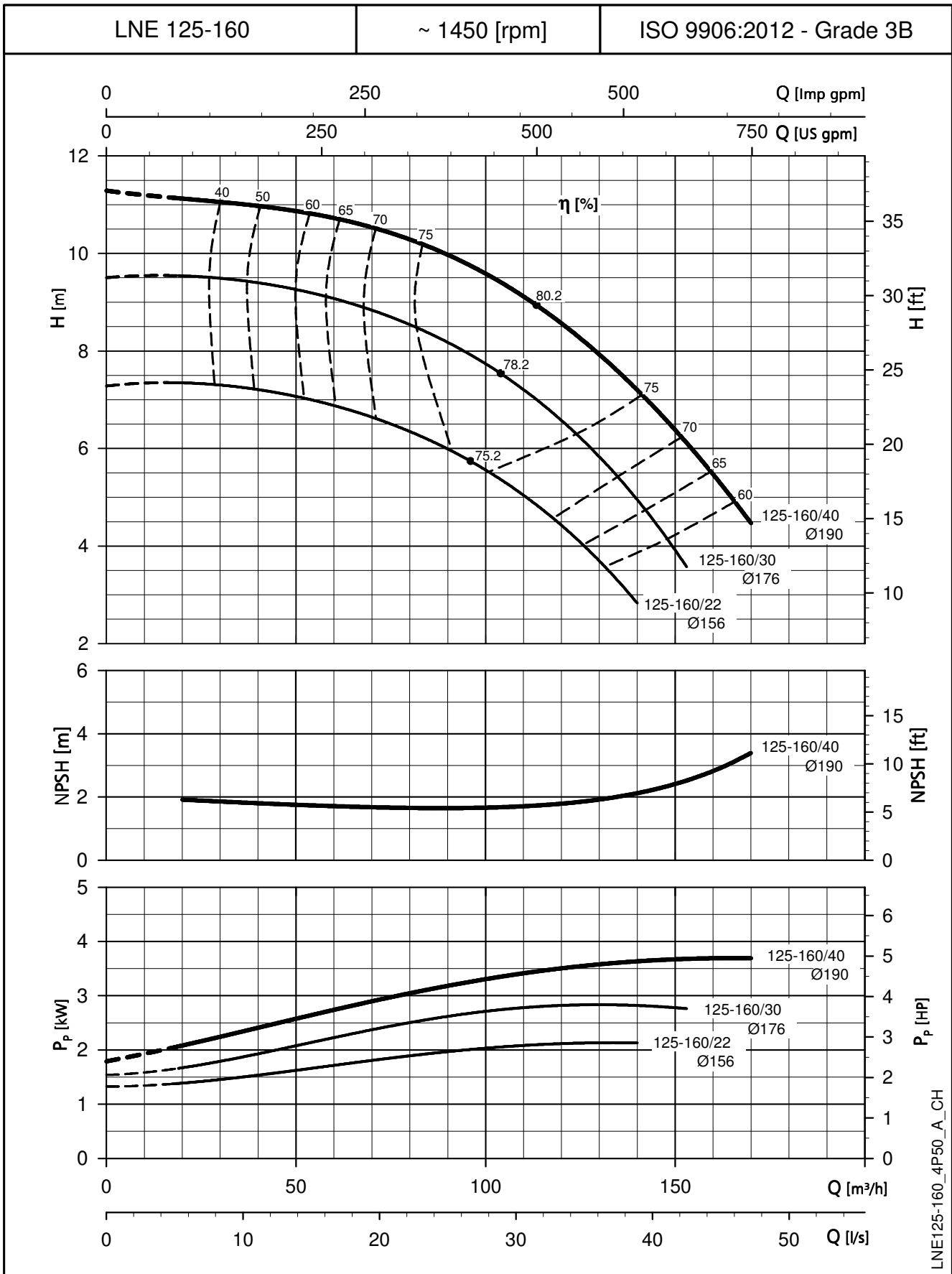

LNE125-160_4P50_A_CH

The NPSH values are laboratory values; for practical use we suggest increasing these values by 0,5 m.
 These performances are valid for liquids with density $\rho = 1,0 \text{ Kg/dm}^3$ and kinematic viscosity $\nu = 1 \text{ mm}^2/\text{sec}$.

e-LNE SERIES

OPERATING CHARACTERISTICS AT 50 Hz, 4 POLES

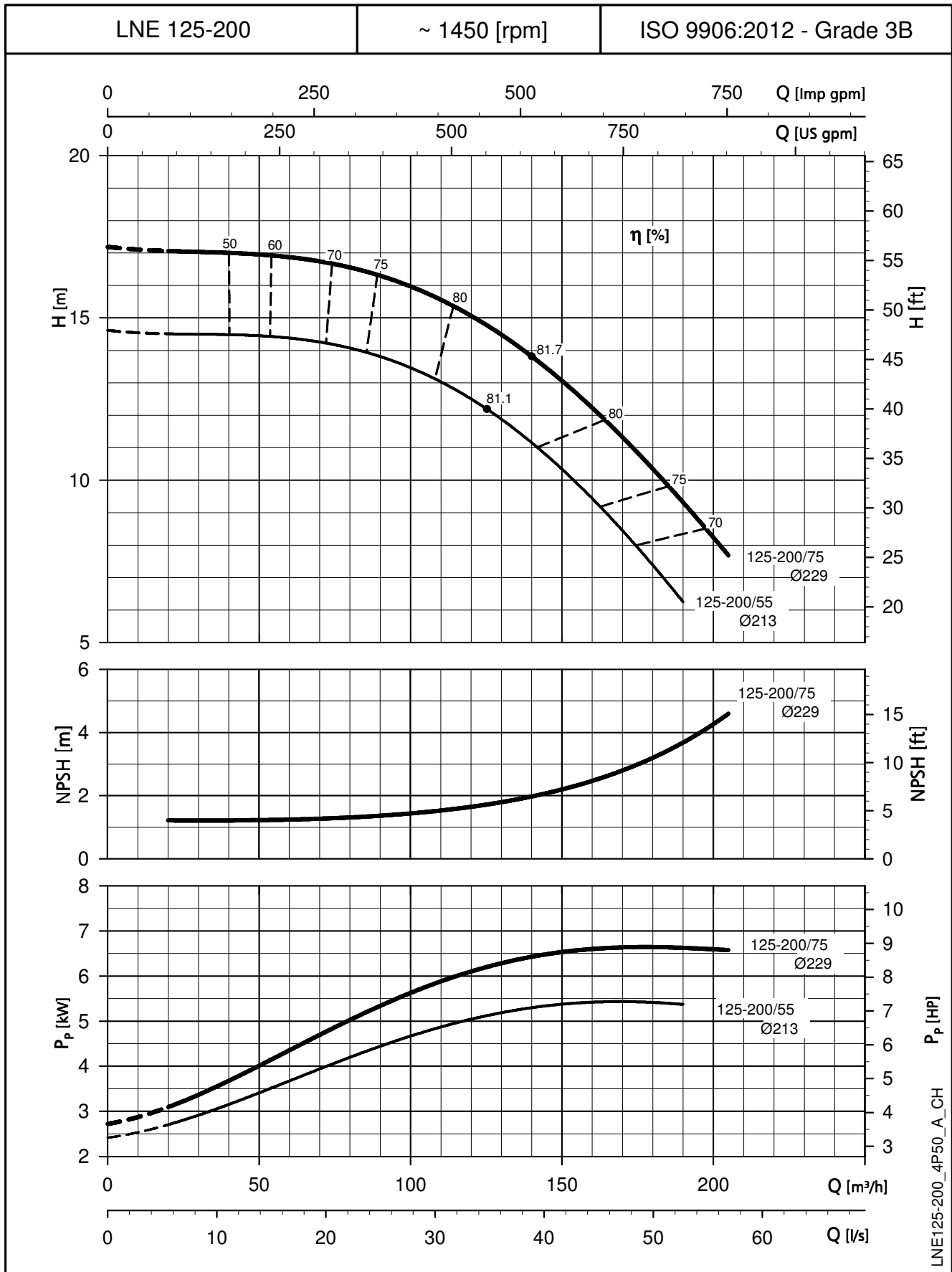

The NPSH values are laboratory values; for practical use we suggest increasing these values by 0,5 m.
 These performances are valid for liquids with density $\rho = 1,0 \text{ Kg/dm}^3$ and kinematic viscosity $\nu = 1 \text{ mm}^2/\text{sec}$.

e-LNE SERIES

OPERATING CHARACTERISTICS AT 50 Hz, 4 POLES

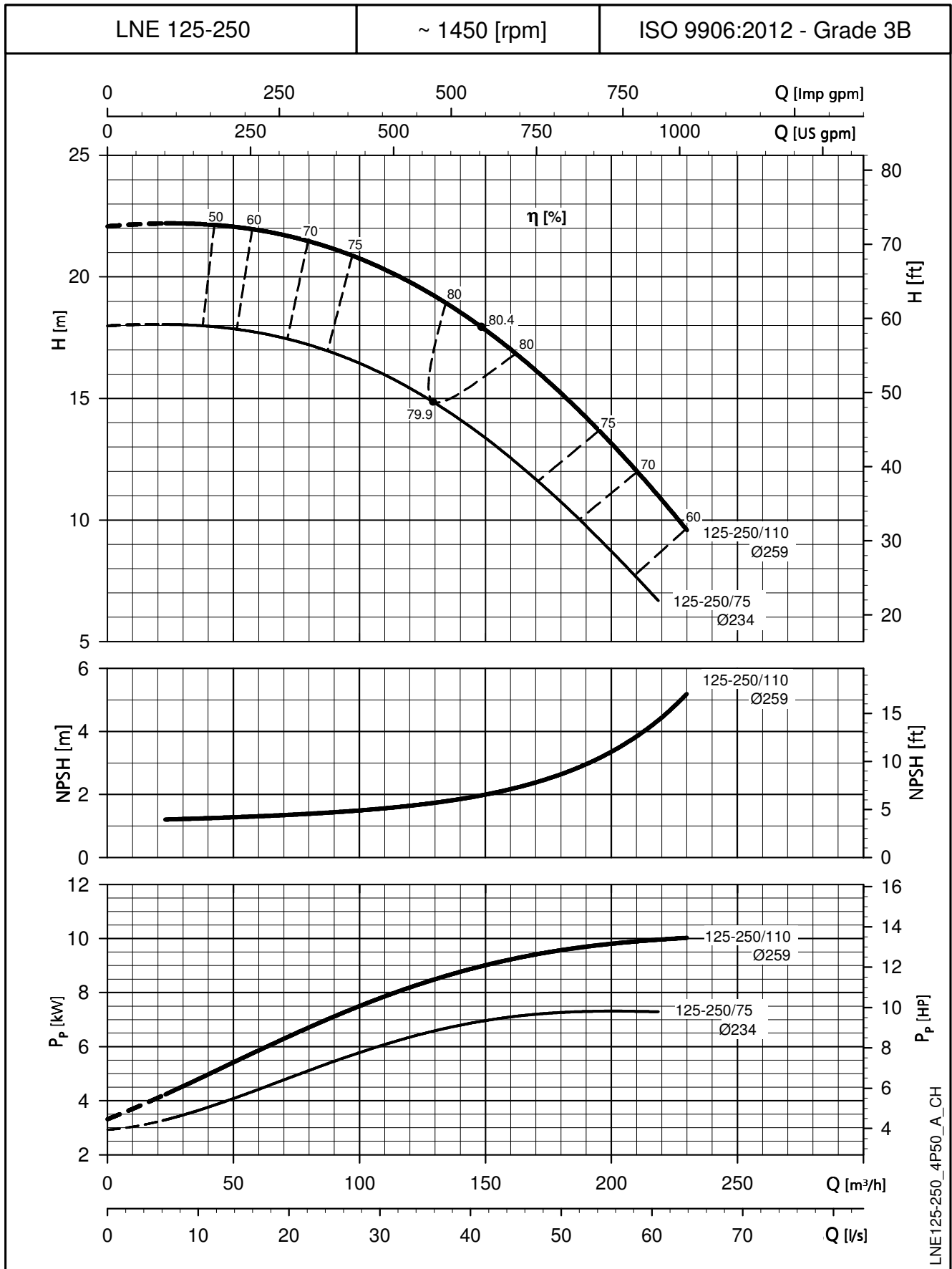

The NPSH values are laboratory values; for practical use we suggest increasing these values by 0,5 m.
 These performances are valid for liquids with density $\rho = 1,0 \text{ Kg/dm}^3$ and kinematic viscosity $\nu = 1 \text{ mm}^2/\text{sec}$.

e-LNE SERIES

OPERATING CHARACTERISTICS AT 50 Hz, 4 POLES

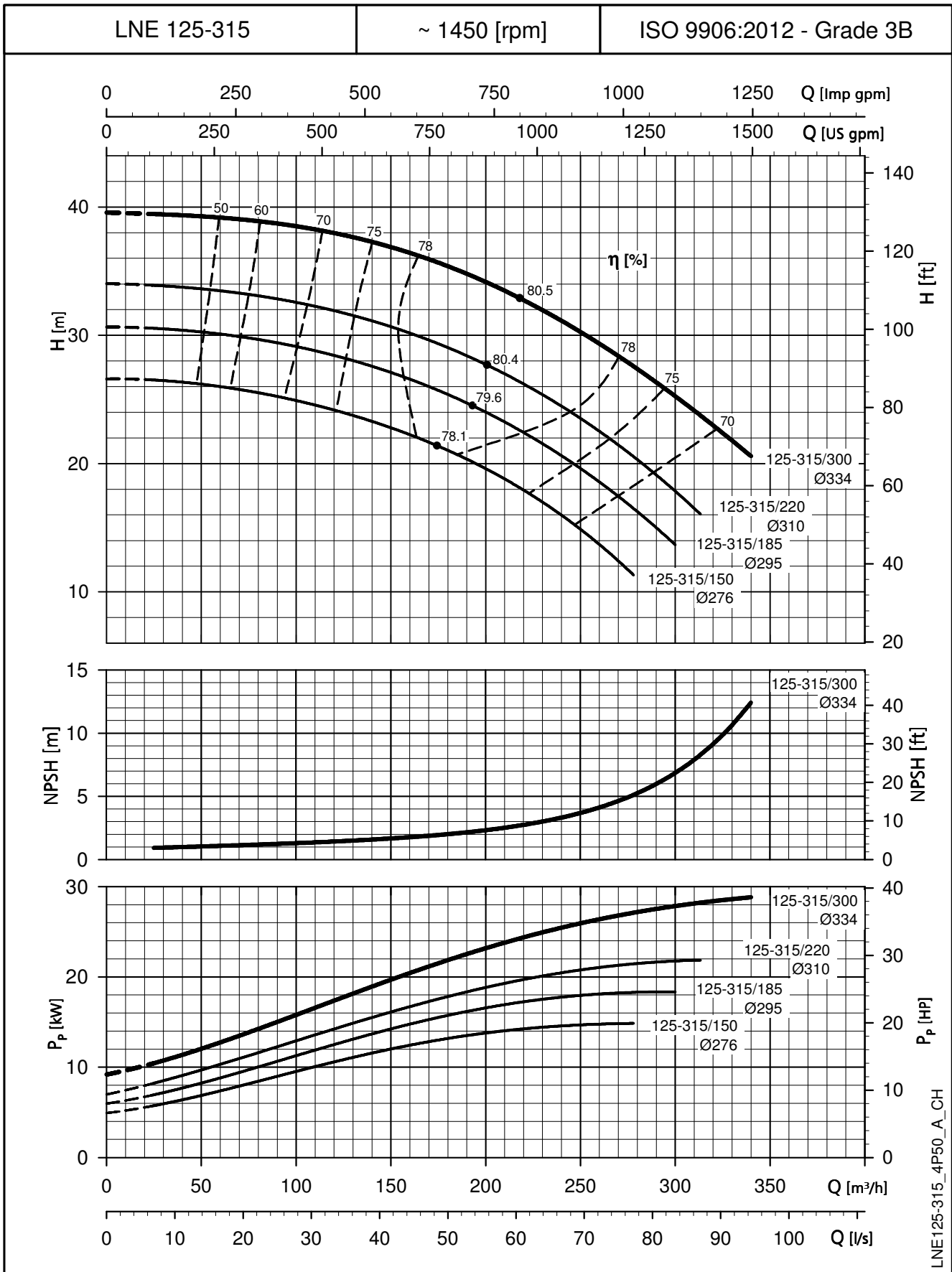

LNE125-315_4P50_A_CH

The NPSH values are laboratory values; for practical use we suggest increasing these values by 0,5 m.
 These performances are valid for liquids with density $\rho = 1,0 \text{ Kg/dm}^3$ and kinematic viscosity $\nu = 1 \text{ mm}^2/\text{sec}$.

e-LNE SERIES

OPERATING CHARACTERISTICS AT 50 Hz, 4 POLES

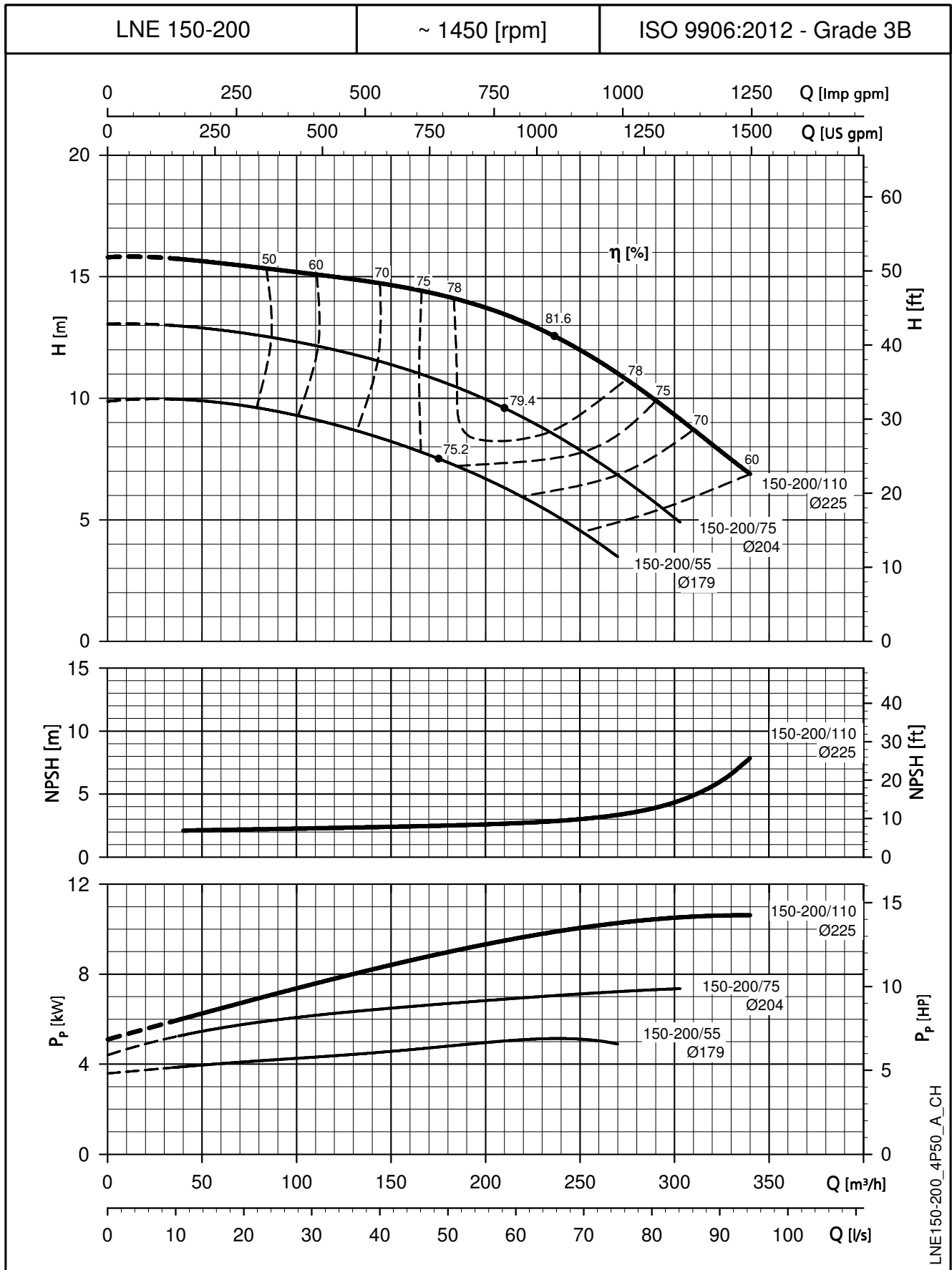

The NPSH values are laboratory values; for practical use we suggest increasing these values by 0,5 m.
 These performances are valid for liquids with density $\rho = 1,0 \text{ Kg/dm}^3$ and kinematic viscosity $\nu = 1 \text{ mm}^2/\text{sec}$.

e-LNE SERIES

OPERATING CHARACTERISTICS AT 50 Hz, 4 POLES

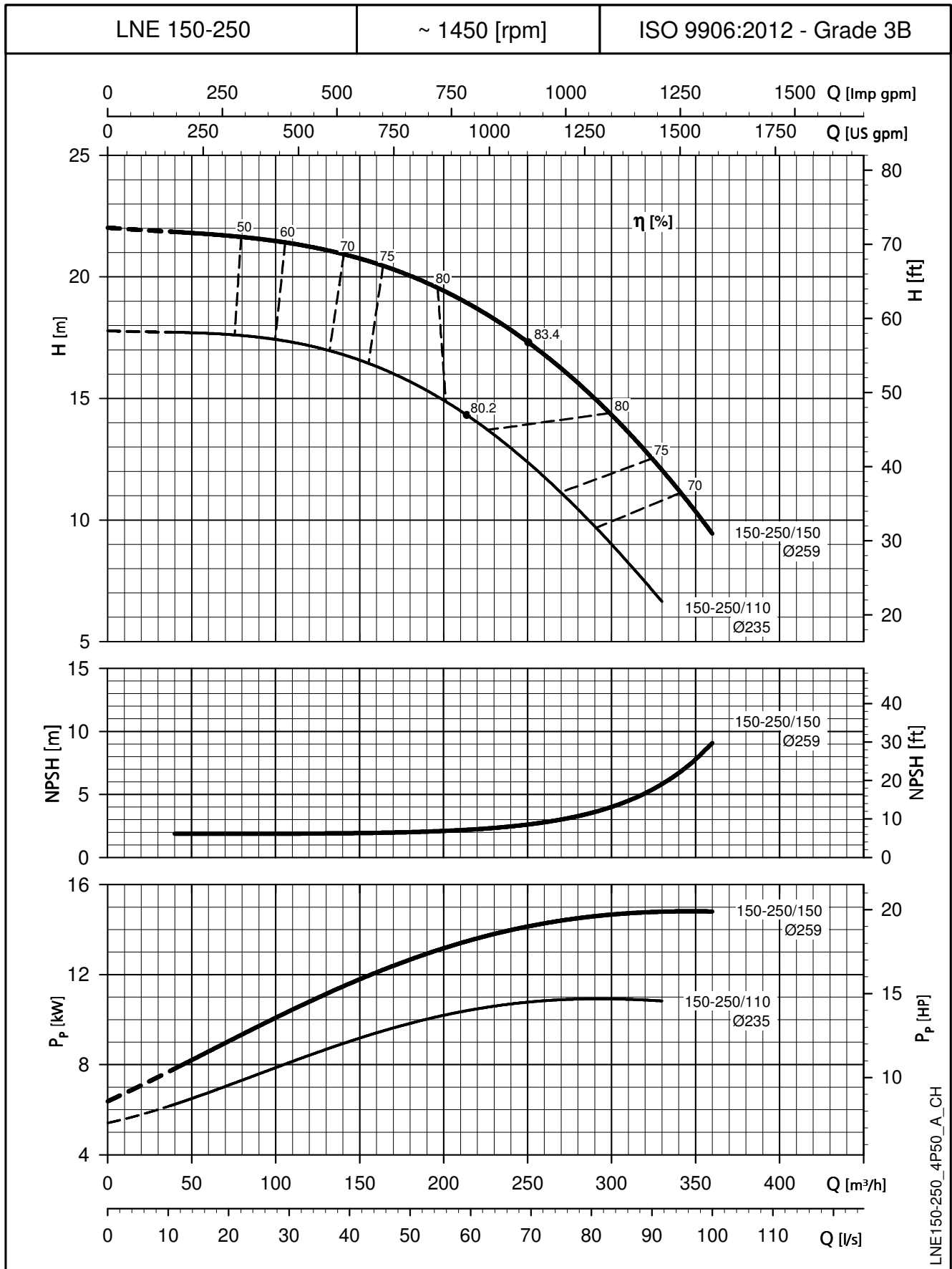

The NPSH values are laboratory values; for practical use we suggest increasing these values by 0,5 m.
 These performances are valid for liquids with density $\rho = 1,0 \text{ Kg/dm}^3$ and kinematic viscosity $\nu = 1 \text{ mm}^2/\text{sec}$.

e-LNE SERIES

OPERATING CHARACTERISTICS AT 50 Hz, 4 POLES

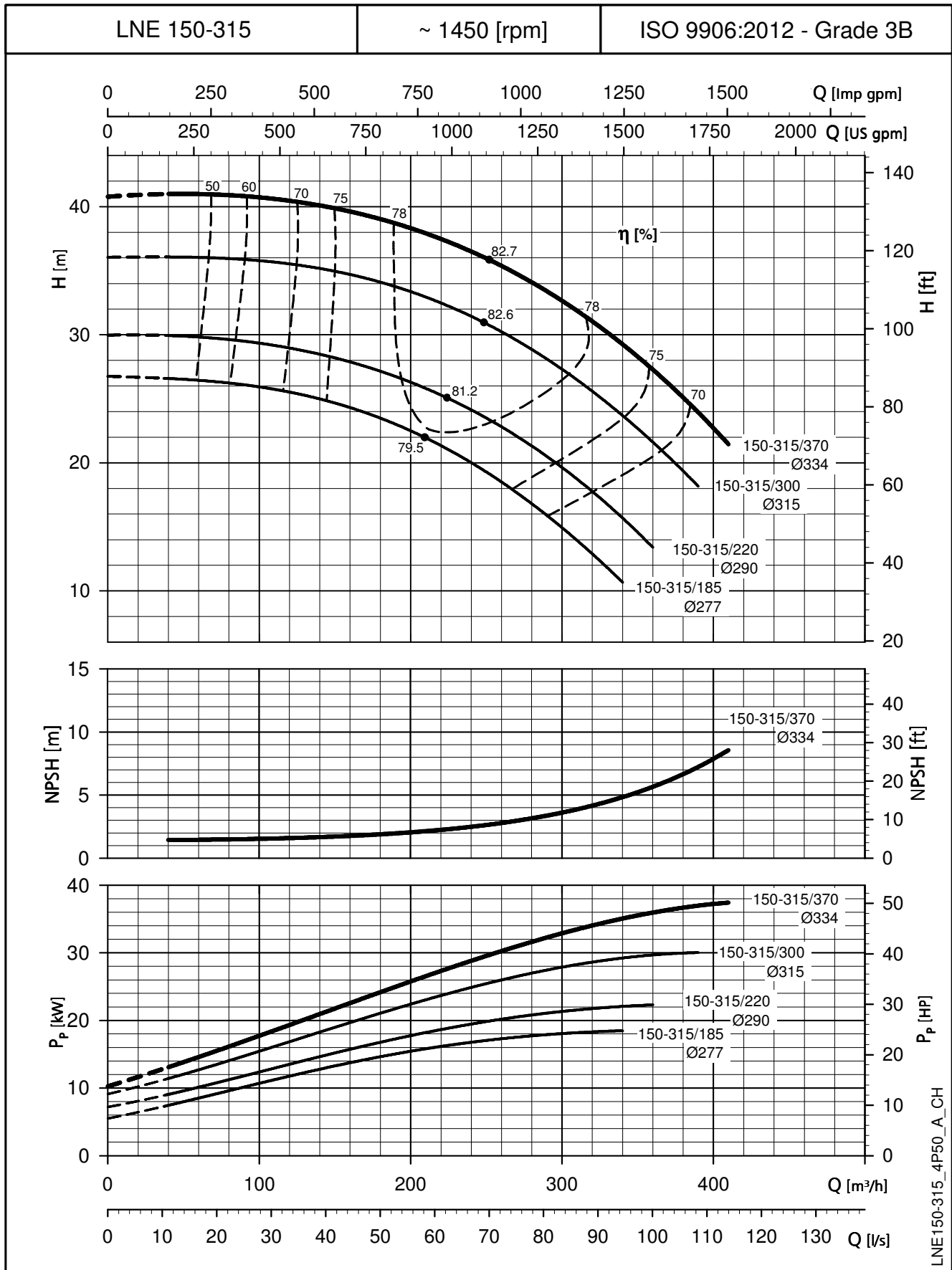

The NPSH values are laboratory values; for practical use we suggest increasing these values by 0,5 m.
 These performances are valid for liquids with density $\rho = 1,0 \text{ Kg/dm}^3$ and kinematic viscosity $\nu = 1 \text{ mm}^2/\text{sec}$.

DIMENSIONS AND WEIGHTS

**LNEE 40, 50, 65, 80 100 SERIES
DIMENSIONS AND WEIGHTS AT 50 Hz, 2 POLES**

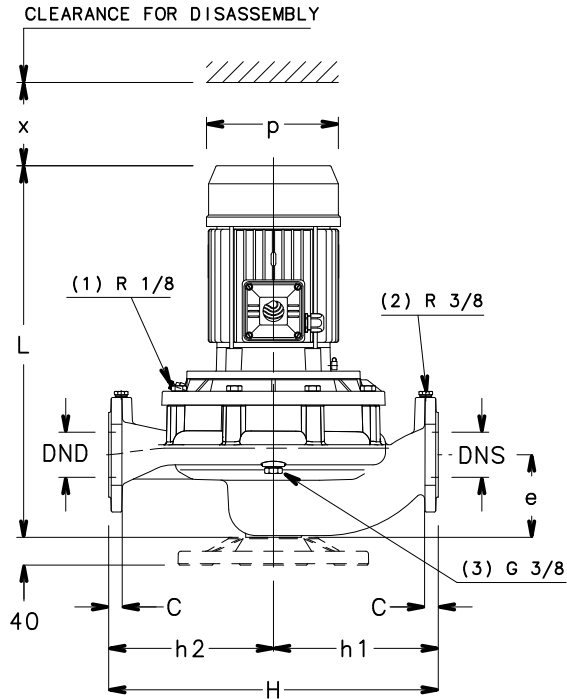

- (1) R 1/8 AIR VALVE
- (2) R 3/8 PRESSURE GAUGE CONNECTOR
- (3) G 3/8 DRAIN

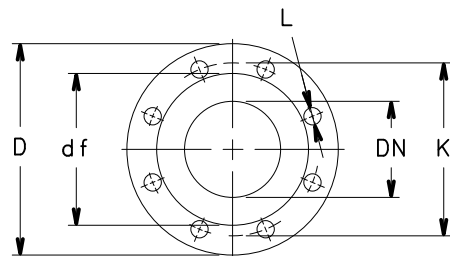
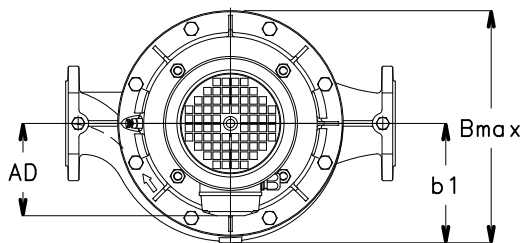
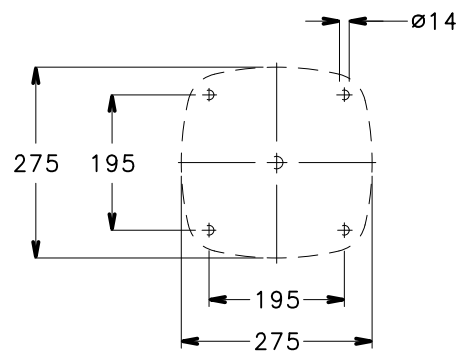

FLANGE

EN1092-2, PN 16 *)					
DN	D	K	C	df	L
32	140	100	18	76	4x19
40	150	110	18	84	4x19
50	165	125	20	99	4x19
65	185	145	20	118	4x19
80	200	160	22	132	8x19
100	230	180	24	157	8x19

*)...VALUE "C" AND "D" MAY VARY FROM STANDARD.

LNEE 40, 50, 65, 80 100 SERIES DIMENSIONS AND WEIGHTS AT 50 Hz, 2 POLES

PUMP TYPE LNEE..2	DIMENSIONS (mm)								B max	H	L	x	WEIGHT kg
	DND	DNS	e	h1	h2	AD	b1	p					
40-125/11/S	40	40	100	160	160	129	128	155	249	320	473	94	33
40-125/15/S	40	40	100	160	160	129	128	155	249	320	473	94	34
40-125/22/P	40	40	100	160	160	134	128	174	254	320	508	94	41
40-125/30/P	40	40	100	160	160	134	128	174	254	320	508	94	42
40-160/30/P	40	40	100	160	160	134	128	174	254	320	508	94	42
40-160/40/P	40	40	100	160	160	154	128	197	274	320	529	94	47
40-160/55/P	40	40	100	160	160	168	128	214	288	320	563	94	56
40-200/40/P	40	40	110	220	220	154	168	197	336	440	529	104	64
40-200/55/P	40	40	110	220	220	168	168	214	336	440	563	104	73
40-200/75/P	40	40	110	220	220	191	168	256	359	440	577	104	92
40-250/92/P	40	40	110	220	220	191	168	256	359	440	615	104	98
40-250/110/P	40	40	110	220	220	191	168	256	359	440	615	104	101
40-250/150/P	40	40	110	220	220	240	168	313	408	440	704	104	141
50-125/15/S	50	50	116	180	160	129	128	155	247	340	479	96	38
50-125/22/P	50	50	116	180	160	134	128	174	252	340	514	96	45
50-125/30/P	50	50	116	180	160	134	128	174	252	340	514	96	46
50-125/40/P	50	50	116	180	160	154	128	197	272	340	535	96	51
50-160/40/P	50	50	116	180	160	154	128	197	272	340	535	96	51
50-160/55/P	50	50	116	180	160	168	128	214	286	340	569	96	60
50-160/75/P	50	50	116	180	160	191	128	256	319	340	583	96	81
50-200/75/P	50	50	111	220	220	191	168	256	359	440	578	108	95
50-200/92/P	50	50	111	220	220	191	168	256	359	440	616	108	101
50-200/110/P	50	50	111	220	220	191	168	256	359	440	616	108	104
50-250/110/P	50	50	111	220	220	191	168	256	359	440	616	108	104
50-250/150/P	50	50	111	220	220	240	168	313	408	440	705	108	144
50-250/185/P	50	50	111	220	220	240	168	313	408	440	705	108	155
50-250/220/P	50	50	111	220	220	240	168	313	408	440	705	108	164
65-125/30/P	65	65	105	190	170	134	148	174	296	360	528	100	58
65-125/40/P	65	65	105	190	170	154	148	197	302	360	549	100	63
65-125/55/P	65	65	105	190	170	168	148	214	316	360	583	100	72
65-125/75/P	65	65	105	190	170	191	148	256	339	360	597	100	91
65-160/75/P	65	65	105	190	170	191	148	256	339	360	597	94	91
65-160/92/P	65	65	105	190	170	191	148	256	339	360	635	94	97
65-160/110/P	65	65	105	190	170	191	148	256	339	360	635	94	100
65-200/110/P	65	65	118	237,5	237,5	191	178	256	360	475	623	105	108
65-200/150/P	65	65	118	237,5	237,5	240	178	313	409	475	712	105	148
65-200/185/P	65	65	118	237,5	237,5	240	178	313	409	475	712	105	159
65-250/185/P	65	65	118	237,5	237,5	240	178	313	409	475	712	105	159
65-250/220/P	65	65	118	237,5	237,5	240	178	313	409	475	712	105	168
80-160/75/P	80	80	114	215	205	191	168	256	359	420	596	111	103
80-160/92/P	80	80	114	215	205	191	168	256	359	420	634	111	109
80-160/110/P	80	80	114	215	205	191	168	256	359	420	634	111	112
80-160/150/P	80	80	114	215	205	240	168	313	408	420	723	111	152
80-160/185/P	80	80	114	215	205	240	168	313	408	420	723	111	163
100-160/110/P	100	100	140	260	240	191	179	256	359	500	665	123	122
100-160/150/P	100	100	140	260	240	240	179	313	408	500	754	123	162
100-160/185/P	100	100	140	260	240	240	179	313	408	500	754	123	173
100-160/220/P	100	100	140	260	240	240	179	313	408	500	754	123	182

NOTE: Pumps supplied with flanges according to EN 1092-2 as standard. For flanges dimensions see drawing.

LNEE-40-100_2p50-en_a_td

LNEE 40, 50, 65, 80 100 SERIES
DIMENSIONS AND WEIGHTS AT 50 Hz, 4 POLES

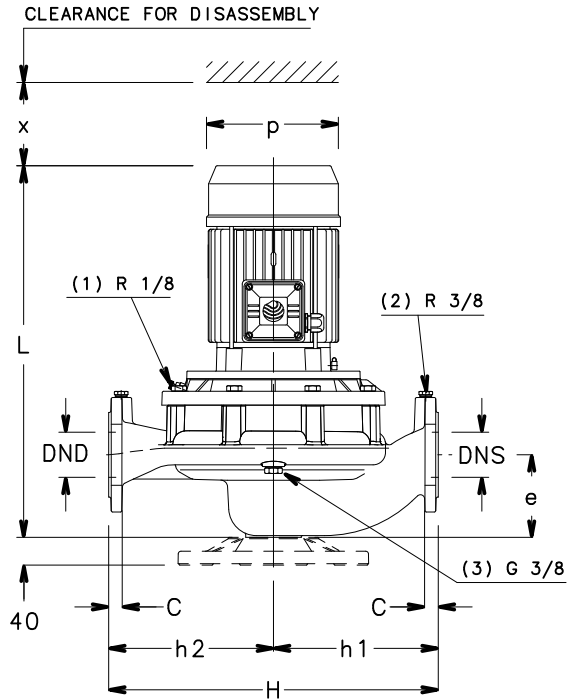

- (1) R 1/8 AIR VALVE
- (2) R 3/8 PRESSURE GAUGE CONNECTOR
- (3) G 3/8 DRAIN

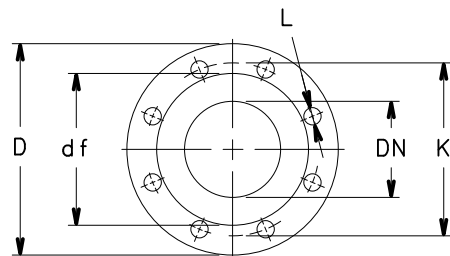
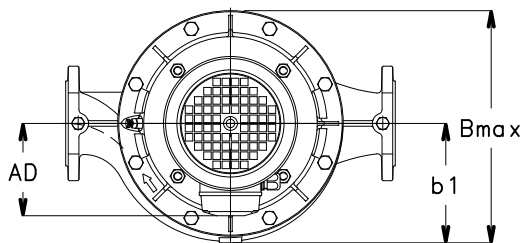
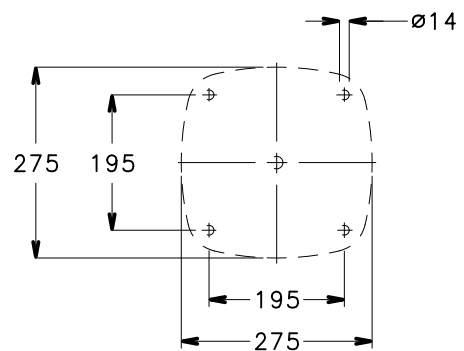

FLANGE

EN1092-2, PN 16 *)					
DN	D	K	C	df	L
32	140	100	18	76	4x19
40	150	110	18	84	4x19
50	165	125	20	99	4x19
65	185	145	20	118	4x19
80	200	160	22	132	8x19
100	230	180	24	157	8x19

*)...VALUE "C" AND "D" MAY VARY FROM STANDARD.

LNEE 40, 50, 65, 80 100 SERIES DIMENSIONS AND WEIGHTS AT 50 Hz, 4 POLES

PUMP TYPE LNEE..4	DIMENSIONS (mm)								B max	H	L	x	WEIGHT kg
	DND	DNS	e	h1	h2	AD	b1	p					
40-125/02B/S	40	40	100	160	160	121	128	140	248	320	441	94	27
40-125/02A/S	40	40	100	160	160	121	128	140	248	320	441	94	27
40-125/02/S	40	40	100	160	160	121	128	140	248	320	441	94	27
40-125/03/S	40	40	100	160	160	121	128	140	248	320	441	94	28
40-160/03/S	40	40	100	160	160	121	128	140	248	320	441	94	28
40-160/05A/S	40	40	100	160	160	129	128	155	249	320	473	94	39
40-160/07/X	40	40	100	160	160	128	128	159	248	320	441	94	42
40-200/05/S	40	40	110	220	220	129	168	155	336	440	473	104	47
40-200/07/X	40	40	110	220	220	128	168	159	336	440	441	104	50
40-200/11/P	40	40	110	220	220	134	168	174	336	440	508	104	56
40-250/15A/P	40	40	110	220	220	134	168	174	336	440	508	104	56
40-250/15/P	40	40	110	220	220	134	168	174	336	440	508	104	60
40-250/22/P	40	40	110	220	220	168	168	214	336	440	532	104	70
50-125/02A/S	50	50	116	180	160	121	128	140	246	340	447	96	31
50-125/02/S	50	50	116	180	160	121	128	140	246	340	447	96	31
50-125/03/S	50	50	116	180	160	121	128	140	246	340	447	96	32
50-125/05/S	50	50	116	180	160	129	128	155	247	340	479	96	34
50-160/05/S	50	50	116	180	160	129	128	155	247	340	479	96	34
50-160/07/X	50	50	116	180	160	128	128	159	246	340	447	96	37
50-160/11/P	50	50	116	180	160	134	128	174	252	340	514	96	45
50-200/11A/P	50	50	111	220	220	134	168	174	336	440	509	108	59
50-200/11/P	50	50	111	220	220	134	168	174	336	440	509	108	59
50-200/15/P	50	50	111	220	220	134	168	174	336	440	509	108	63
50-250/15/P	50	50	111	220	220	134	168	174	336	440	509	108	63
50-250/22A/P	50	50	111	220	220	168	168	214	336	440	533	108	73
50-250/22/P	50	50	111	220	220	168	168	214	336	440	533	108	73
50-250/30/P	50	50	111	220	220	168	168	214	336	440	564	108	77
65-125/03/S	65	65	105	190	170	121	148	140	296	360	461	100	44
65-125/05/S	65	65	105	190	170	129	148	155	296	360	493	100	46
65-125/07/X	65	65	105	190	170	128	148	159	296	360	461	100	49
65-125/11/P	65	65	105	190	170	134	148	174	296	360	528	100	55
65-160/11A/P	65	65	105	190	170	134	148	174	296	360	528	94	55
65-160/11/P	65	65	105	190	170	134	148	174	296	360	528	94	55
65-160/15/P	65	65	105	190	170	134	148	174	296	360	528	94	59
65-200/15/P	65	65	118	237,5	237,5	134	178	174	347	475	516	105	67
65-200/22A/P	65	65	118	237,5	237,5	168	178	214	347	475	540	105	77
65-200/22/P	65	65	118	237,5	237,5	168	178	214	347	475	540	105	77
65-250/22/P	65	65	118	237,5	237,5	168	178	214	347	475	540	105	77
65-250/30/P	65	65	118	237,5	237,5	168	178	214	347	475	571	105	81
65-250/40/P	65	65	118	237,5	237,5	168	178	214	347	475	616	105	100
80-160/15B/P	80	80	114	215	205	134	168	174	336	420	539	111	67
80-160/15A/P	80	80	114	215	205	134	168	174	336	420	539	111	67
80-160/15/P	80	80	114	215	205	134	168	174	336	420	539	111	67
80-160/22A/P	80	80	114	215	205	168	168	214	336	420	563	111	78
80-160/22/P	80	80	114	215	205	168	168	214	336	420	563	111	78
100-160/15/P	100	100	140	260	240	134	179	174	347	500	558	123	81
100-160/22A/P	100	100	140	260	240	168	179	214	347	500	582	123	91
100-160/22/P	100	100	140	260	240	168	179	214	347	500	582	123	91
100-160/30/P	100	100	140	260	240	168	179	214	347	500	613	123	95

NOTE: Pumps supplied with flanges according to EN 1092-2 as standard. For flanges dimensions see drawing.

LNEE-40-100_4p50-en_a_td

LNES 40, 50, 65 SERIES
DIMENSIONS AND WEIGHTS AT 50 Hz, 2 POLES

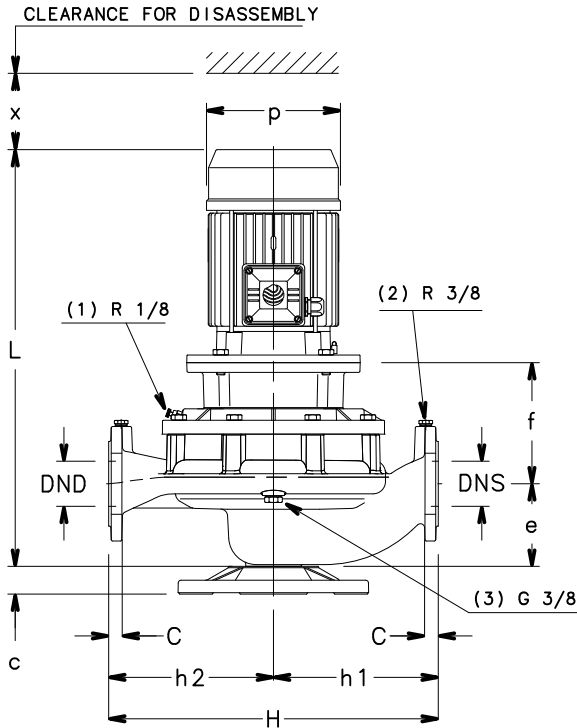

- (1) R 1/8 AIR VALVE
- (2) R 3/8 PRESSURE GAUGE CONNECTOR
- (3) G 3/8 DRAIN

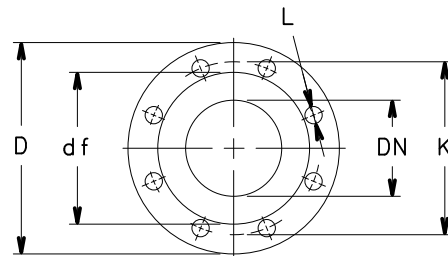
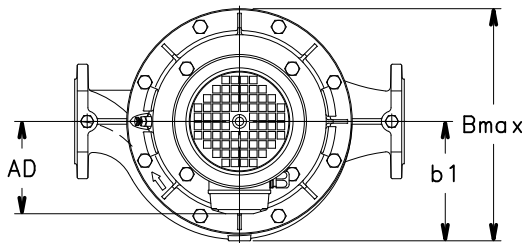
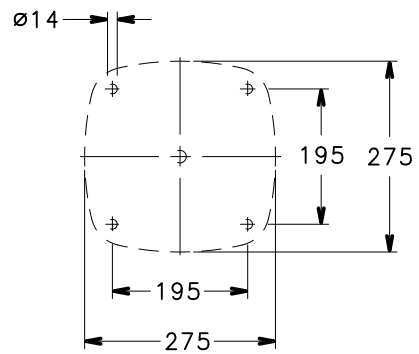

FLANGE

EN1092-2, PN 16 *)					
DN	D	K	C	df	L
32	140	100	18	76	4x19
40	150	110	18	84	4x19
50	165	125	20	99	4x19
65	185	145	20	118	4x19
80	200	160	22	132	8x19
100	230	180	24	157	8x19

*)...VALUE "C" AND "D" MAY VARY FROM STANDARD.

LNES 40, 50, 65 SERIES DIMENSIONS AND WEIGHTS AT 50 Hz, 2 POLES

PUMP TYPE LNES..2	DIMENSIONS (mm)									B max	H	L	x	WEIGHT kg
	DND	DNS	e	f	h1	h2	AD	b1	p					
40-125/11/S	40	40	100	165	160	160	129	128	155	249	320	528	94	33
40-125/15/S	40	40	100	165	160	160	129	128	155	249	320	582	94	37
40-125/22/P	40	40	100	165	160	160	134	128	174	254	320	563	94	44
40-125/30/P	40	40	100	175	160	160	134	128	174	254	320	573	94	49
40-160/30/P	40	40	100	175	160	160	134	128	174	254	320	573	94	49
40-160/40/P	40	40	100	175	160	160	154	128	197	274	320	594	94	52
40-160/55/P	40	40	100	202	160	160	168	128	214	288	320	677	94	65
40-200/40/P	40	40	110	165	220	220	154	168	197	336	440	594	104	69
40-200/55/P	40	40	110	192	220	220	168	168	214	336	440	677	104	82
40-200/75/P	40	40	110	192	220	220	191	168	256	359	440	669	104	101
40-250/110A/P	40	40	110	222	220	220	191	168	256	359	440	760	104	118
40-250/110/P	40	40	110	222	220	220	191	168	256	359	440	760	104	118
40-250/150/P	40	40	110	222	220	220	240	168	313	408	440	826	104	151
50-125/15/S	50	50	116	155	180	160	129	128	155	247	340	534	96	41
50-125/22/P	50	50	116	155	180	160	134	128	174	252	340	569	96	48
50-125/30/P	50	50	116	165	180	160	134	128	174	252	340	579	96	52
50-125/40/P	50	50	116	165	180	160	154	128	197	272	340	600	96	55
50-160/40/P	50	50	116	165	180	160	154	128	197	272	340	600	96	55
50-160/55/P	50	50	116	192	180	160	168	128	214	286	340	683	96	65
50-160/75/P	50	50	116	192	180	160	191	128	256	319	340	675	96	84
50-200/75/P	50	50	111	192	220	220	191	168	256	359	440	670	108	104
50-200/110A/P	50	50	111	222	220	220	191	168	256	359	440	761	108	121
50-200/110/P	50	50	111	222	220	220	191	168	256	359	440	761	108	121
50-250/110/P	50	50	111	222	220	220	191	168	256	359	440	761	108	121
50-250/150/P	50	50	111	222	220	220	240	168	313	408	440	827	108	154
50-250/185/P	50	50	111	222	220	220	240	168	313	408	440	827	108	163
50-250/220/P	50	50	111	222	220	220	240	168	313	408	440	827	108	174
65-125/30/P	65	65	105	190	190	170	134	148	174	296	360	593	100	60
65-125/40/P	65	65	105	190	190	170	154	148	197	302	360	614	100	63
65-125/55/P	65	65	105	217	190	170	168	148	214	316	360	697	100	72
65-125/75/P	65	65	105	217	190	170	191	148	256	339	360	689	100	95
65-160/75/P	65	65	105	217	190	170	191	148	256	339	360	689	94	96
65-160/110A/P	65	65	105	247	190	170	191	148	256	339	360	780	94	117
65-160/110/P	65	65	105	247	190	170	191	148	256	339	360	780	94	117
65-200/110/P	65	65	118	222	237,5	237,5	191	178	256	360	475	768	105	125
65-200/150/P	65	65	118	222	237,5	237,5	240	178	313	409	475	834	105	158
65-200/185/P	65	65	118	222	237,5	237,5	240	178	313	409	475	834	105	167
65-250/185/P	65	65	118	222	237,5	237,5	240	178	313	409	475	834	105	167
65-250/220/P	65	65	118	222	237,5	237,5	240	178	313	409	475	834	105	178
65-250/300/W	65	65	118	228	237,5	237,5	317	178	402	518	475	1003	105	287

NOTE: Pumps supplied with flanges according to EN 1092-2 as standard. For flanges dimensions see drawing.

LNES-40-50-65_2p50-en_a_td

LNES 40, 50, 65 SERIES
DIMENSIONS AND WEIGHTS AT 50 Hz, 4 POLES

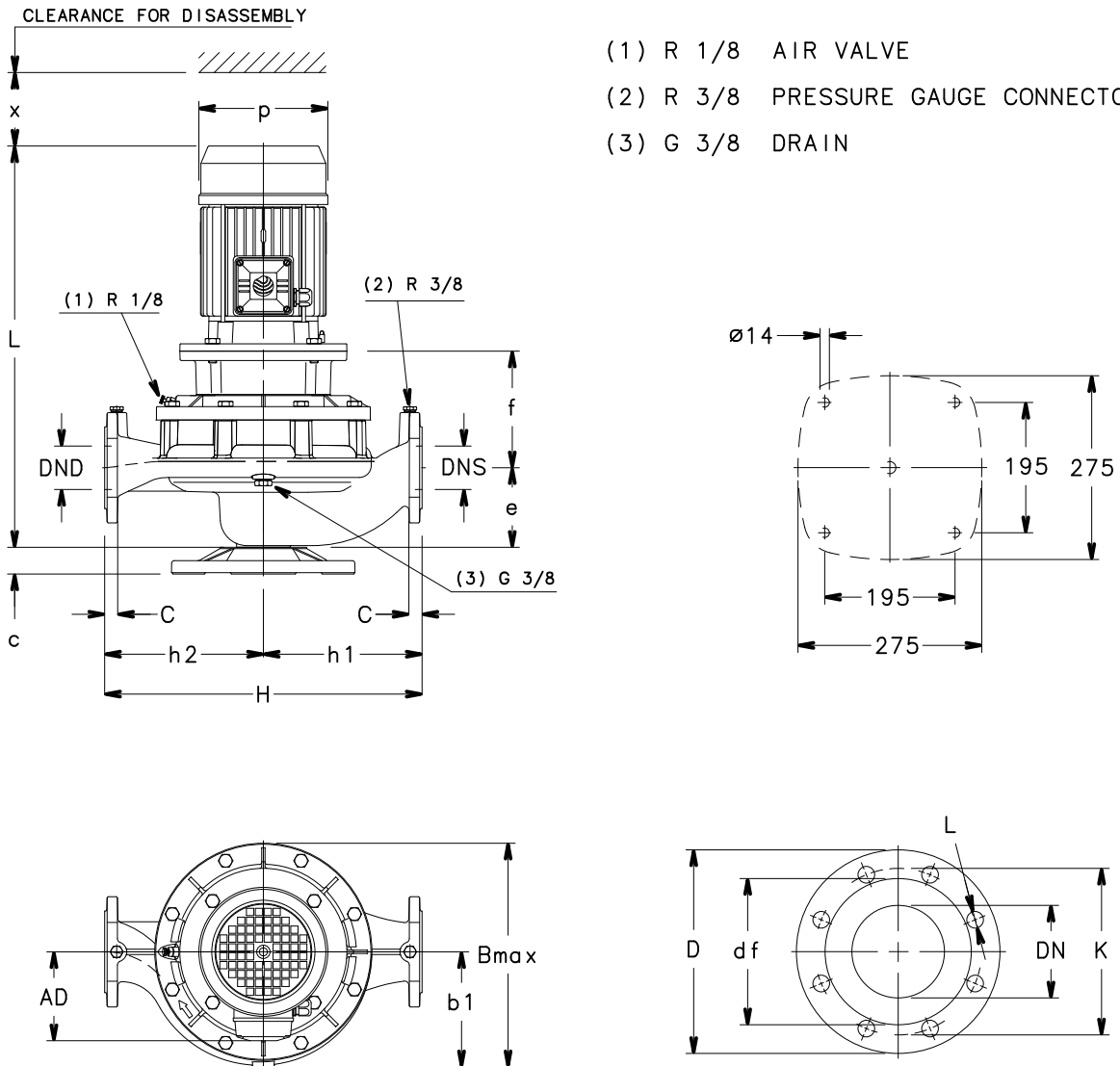

FLANGE

EN1092-2, PN 16 *)					
DN	D	K	C	df	L
32	140	100	18	76	4x19
40	150	110	18	84	4x19
50	165	125	20	99	4x19
65	185	145	20	118	4x19
80	200	160	22	132	8x19
100	230	180	24	157	8x19

*)...VALUE "C" AND "D" MAY VARY FROM STANDARD.

LNES 40, 50, 65 SERIES DIMENSIONS AND WEIGHTS AT 50 Hz, 4 POLES

PUMP TYPE LNES..4	DIMENSIONS (mm)									B max	H	L	x	WEIGHT kg
	DND	DNS	e	f	h1	h2	AD	b1	p					
40-160/05/S	40	40	100	165	160	160	129	128	155	249	320	528	94	33
40-160/07/X	40	40	100	165	160	160	128	128	159	248	320	496	94	36
40-200/05/S	40	40	110	155	220	220	129	168	155	336	440	528	104	50
40-200/07/X	40	40	110	155	220	220	128	168	159	336	440	496	104	53
40-200/11/P	40	40	110	155	220	220	134	168	174	336	440	563	104	59
40-250/11/P	40	40	110	155	220	220	134	168	174	336	440	563	104	59
40-250/15A/P	40	40	110	155	220	220	134	168	174	336	440	563	104	63
40-250/15/P	40	40	110	155	220	220	134	168	174	336	440	563	104	63
40-250/22/P	40	40	110	165	220	220	168	168	214	336	440	597	104	74
50-125/05/S	50	50	116	155	180	160	129	128	155	247	340	534	96	37
50-160/05/S	50	50	116	155	180	160	129	128	155	247	340	534	96	37
50-160/07/X	50	50	116	155	180	160	128	128	159	246	340	502	96	40
50-160/11/P	50	50	116	155	180	160	134	128	174	252	340	569	96	46
50-200/11A/P	50	50	111	155	220	220	134	168	174	336	440	564	108	62
50-200/11/P	50	50	111	155	220	220	134	168	174	336	440	564	108	62
50-200/15/P	50	50	111	155	220	220	134	168	174	336	440	564	108	66
50-250/15/P	50	50	111	155	220	220	134	168	174	336	440	564	108	66
50-250/22A/P	50	50	111	165	220	220	168	168	214	336	440	598	108	77
50-250/22/P	50	50	111	165	220	220	168	168	214	336	440	598	108	77
50-250/30/P	50	50	111	165	220	220	168	168	214	336	440	629	108	81
65-125/05/S	65	65	105	180	190	170	129	148	155	296	360	548	100	49
65-125/07/X	65	65	105	180	190	170	128	148	159	296	360	516	100	52
65-125/11/P	65	65	105	180	190	170	134	148	174	296	360	583	100	58
65-160/11A/P	65	65	105	180	190	170	134	148	174	296	360	583	94	58
65-160/11/P	65	65	105	180	190	170	134	148	174	296	360	583	94	58
65-160/15/P	65	65	105	180	190	170	134	148	174	296	360	583	94	62
65-200/15/P	65	65	118	155	237,5	237,5	134	178	174	347	475	571	105	70
65-200/22A/P	65	65	118	165	237,5	237,5	168	178	214	347	475	605	105	81
65-200/22/P	65	65	118	165	237,5	237,5	168	178	214	347	475	605	105	81
65-250/22/P	65	65	118	165	237,5	237,5	168	178	214	347	475	605	105	81
65-250/30/P	65	65	118	165	237,5	237,5	168	178	214	347	475	636	105	85
65-250/40/P	65	65	118	165	237,5	237,5	168	178	214	347	475	681	105	104

NOTE: Pumps supplied with flanges according to EN 1092-2 as standard. For flanges dimensions see drawing.

LNES-40-50-65_4p50-en_a_td

LNES 80, 100 SERIES
DIMENSIONS AND WEIGHTS AT 50 Hz, 2 POLES

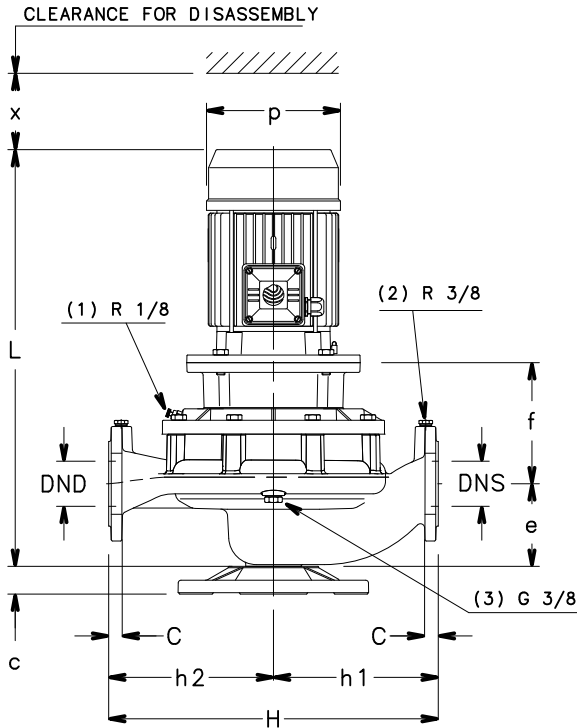

- (1) R 1/8 AIR VALVE
- (2) R 3/8 PRESSURE GAUGE CONNECTOR
- (3) G 3/8 DRAIN

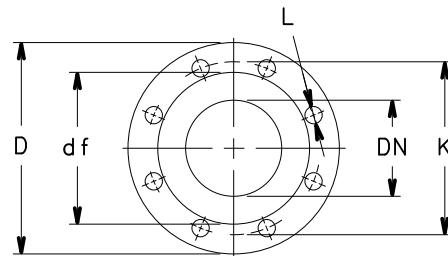
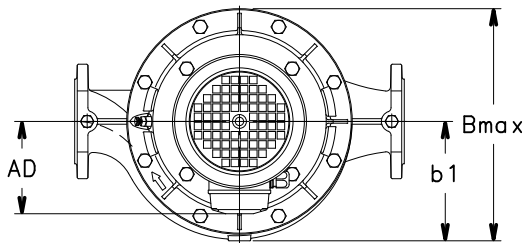
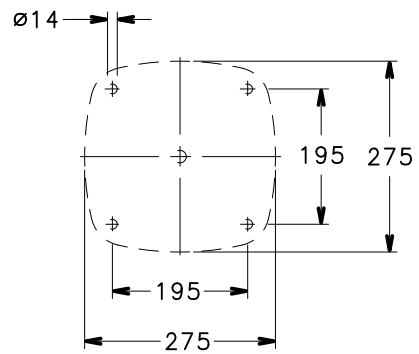

FLANGE

EN1092-2, PN 16 *)					
DN	D	K	C	df	L
32	140	100	18	76	4x19
40	150	110	18	84	4x19
50	165	125	20	99	4x19
65	185	145	20	118	4x19
80	200	160	22	132	8x19
100	230	180	24	157	8x19

*)...VALUE "C" AND "D" MAY VARY FROM STANDARD.

LNES 80, 100 SERIES DIMENSIONS AND WEIGHTS AT 50 Hz, 2 POLES

PUMP TYPE LNES..2	DIMENSIONS (mm)									B max	H	L	x	WEIGHT kg
	DND	DNS	e	f	h1	h2	AD	b1	p					
80-160/75/P	80	80	114	207	215	205	191	168	256	359	420	688	111	108
80-160/110A/P	80	80	114	237	215	205	191	168	256	359	420	779	111	129
80-160/110/P	80	80	114	237	215	205	191	168	256	359	420	779	111	129
80-160/150/P	80	80	114	237	215	205	240	168	313	408	420	845	111	162
80-160/185/P	80	80	114	237	215	205	240	168	313	408	420	845	111	171
80-200/185/P	80	80	132	240	265	235	240	185	313	408	500	866	130	169
80-200/220/P	80	80	132	240	265	235	240	185	313	408	500	866	130	180
80-200/300/W	80	80	132	246	265	235	317	185	402	518	500	1035	130	289
80-250/370/W	80	80	132	246	265	235	317	185	402	518	500	1035	130	304
100-160/110/P	100	100	140	240	260	240	191	179	256	359	500	810	123	139
100-160/150/P	100	100	140	240	260	240	240	179	313	408	500	876	123	172
100-160/185/P	100	100	140	240	260	240	240	179	313	408	500	876	123	181
100-160/220/P	100	100	140	240	260	240	240	179	313	408	500	876	123	192
100-200/220/P	100	100	175	240	300	250	240	201	313	410	550	909	152	196
100-200/300/W	100	100	175	246	300	250	317	201	402	518	550	1078	152	296
100-200/370/W	100	100	175	246	300	250	317	201	402	518	550	1078	152	311
100-250/370/W	100	100	175	246	300	250	317	201	402	518	550	1078	152	311

NOTE: Pumps supplied with flanges according to EN 1092-2 as standard. For flanges dimensions see drawing.

LNES-80-100_2p50-en_a_td

**LNES 80, 100 SERIES
DIMENSIONS AND WEIGHTS AT 50 Hz, 4 POLES**

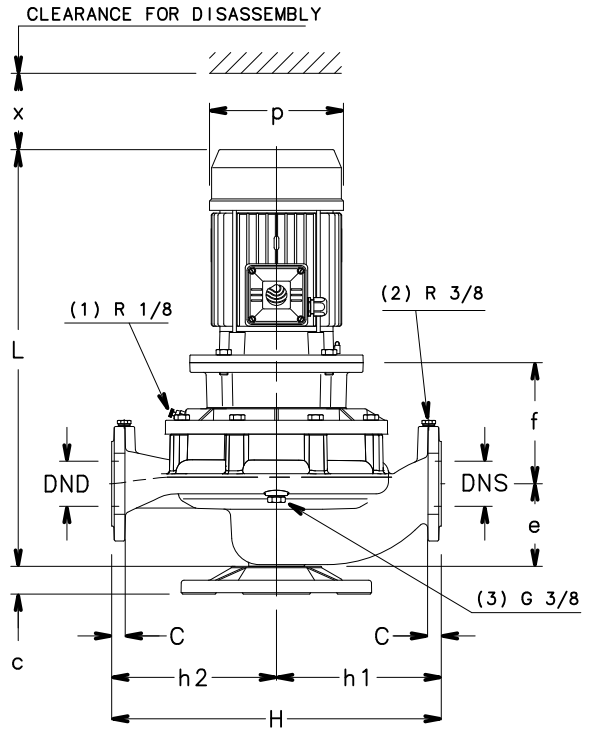

- (1) R 1/8 AIR VALVE
- (2) R 3/8 PRESSURE GAUGE CONNECTOR
- (3) G 3/8 DRAIN

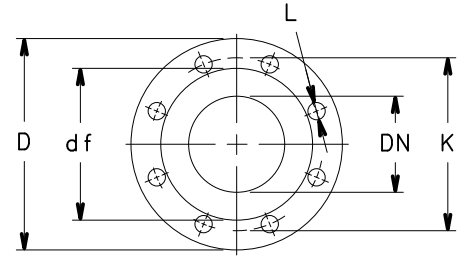
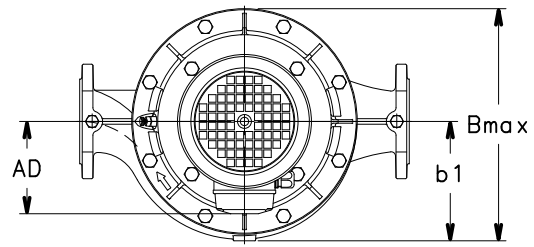
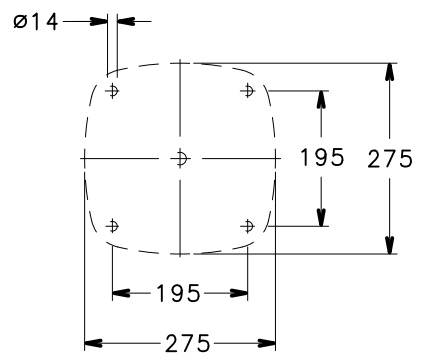

FLANGE

EN1092-2, PN 16 *)					
DN	D	K	C	df	L
32	140	100	18	76	4x19
40	150	110	18	84	4x19
50	165	125	20	99	4x19
65	185	145	20	118	4x19
80	200	160	22	132	8x19
100	230	180	24	157	8x19

*)...VALUE "C" AND "D" MAY VARY FROM STANDARD.

LNES 80, 100 SERIES DIMENSIONS AND WEIGHTS AT 50 Hz, 4 POLES

PUMP TYPE LNES..4	DIMENSIONS (mm)									B max	H	L	x	WEIGHT kg
	DND	DNS	e	f	h1	h2	AD	b1	p					
80-160/11A/P	80	80	114	170	215	205	134	168	174	336	420	582	111	68
80-160/11/P	80	80	114	170	215	205	134	168	174	336	420	582	111	68
80-160/15/P	80	80	114	170	215	205	134	168	174	336	420	582	111	72
80-160/22A/P	80	80	114	170	215	205	168	168	214	336	420	616	111	85
80-160/22/P	80	80	114	180	215	205	168	168	214	336	420	616	111	85
80-200/22/P	80	80	132	183	265	235	168	185	214	353	500	637	130	83
80-200/30/P	80	80	132	183	265	235	168	185	214	353	500	668	130	87
80-200/40/P	80	80	132	183	265	235	168	185	214	353	500	713	130	106
80-250/55A/P	80	80	132	210	265	235	191	185	256	359	500	727	130	117
80-250/55/P	80	80	132	210	265	235	191	185	256	359	500	727	130	117
80-250/75/P	80	80	132	210	265	235	191	185	256	359	500	727	130	121
100-160/15/P	100	100	140	175	260	240	134	179	174	347	500	613	123	84
100-160/22A/P	100	100	140	185	260	240	168	179	214	347	500	647	123	95
100-160/22/P	100	100	140	185	260	240	168	179	214	347	500	647	123	95
100-160/30/P	100	100	140	185	260	240	168	179	214	347	500	678	123	99
100-200/30/P	100	100	175	183	300	250	134	201	174	371	550	711	152	103
100-200/40/P	100	100	175	183	300	250	168	201	214	371	550	756	152	122
100-200/55A/P	100	100	175	210	300	250	168	201	214	371	550	790	152	133
100-200/55/P	100	100	175	210	300	250	168	201	214	371	550	790	152	133
100-250/55A/P	100	100	175	210	300	250	191	201	256	371	550	790	152	133
100-250/55/P	100	100	175	210	300	250	191	201	256	371	550	790	152	133
100-250/75/P	100	100	175	210	300	250	191	201	256	371	550	790	152	137
100-250/110/P	100	100	175	240	300	250	240	201	313	410	550	909	152	201

NOTE: Pumps supplied with flanges according to EN 1092-2 as standard. For flanges dimensions see drawing.

LNES-80-100_4p50-en_a_td

**LNES 125, 150 SERIES
DIMENSIONS AND WEIGHTS AT 50 Hz, 4 POLES**

TYPE A

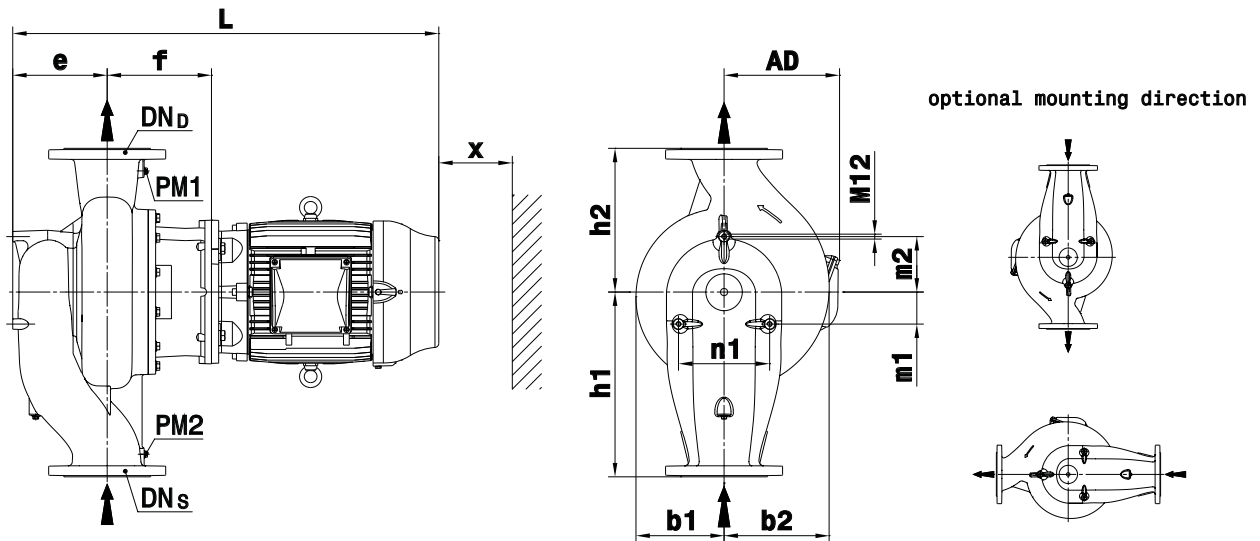

TYPE B

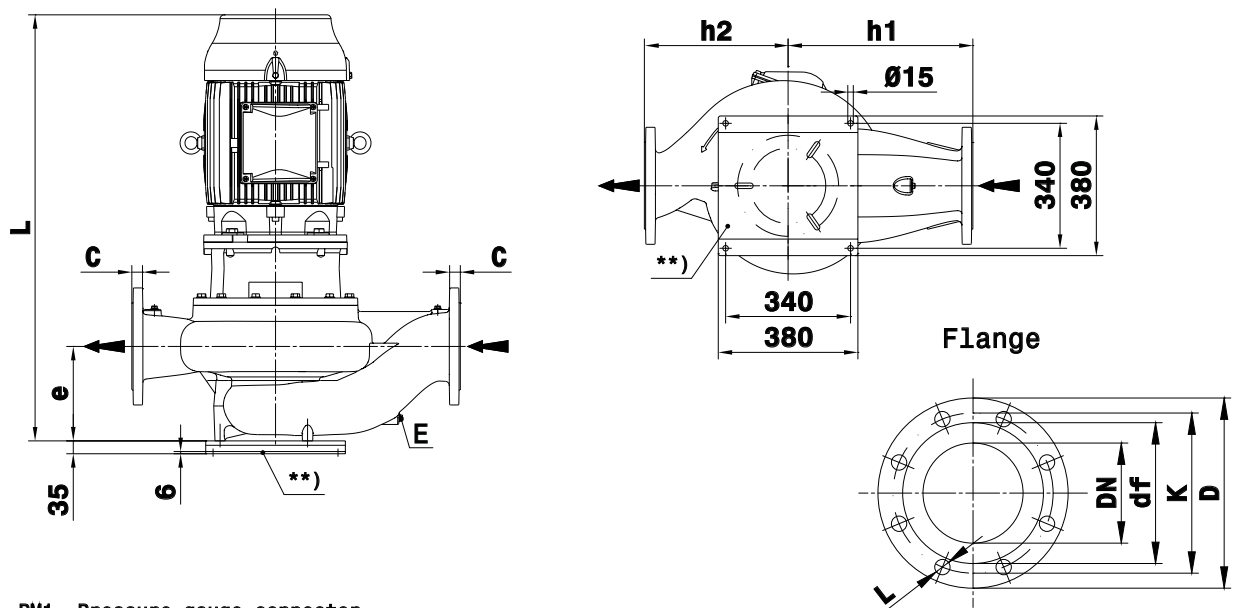

PM1..Pressure gauge connector
PM2..Pressure gauge connector
E....Drain

*)...Value C and D may vary from standard

**)..Support base for horizontal installation 8kg (optional)

TYPE A only up to 7,5kW

Connections	
PM1 / PM2	1/4"
E	1/4"

EN1092-2, PN 16 *)					
DN	D	K	C	df	L
125	255	210	26	184	8x19
150	285	240	26	211	8x23

LNES-EN_A_DD

LNES 125, 150 SERIES DIMENSIONS AND WEIGHTS AT 50 Hz, 4 POLES

PUMP TYPE LNES..4	DIMENSIONS (mm)														WEIGHT
	DNS	DND	e	f	h1	h2	m1	m2	n1	b1	b2	x	AD	L	(kg) G
125-160/22/W	125	125	215	183	340	280	60	105	172	166	212	140	167	714	115
125-160/30/W	125	125	215	183	340	280	60	105	172	166	212	140	167	758	121
125-160/40/W	125	125	215	183	340	280	60	105	172	166	212	140	192	731	127
125-200/55/W	125	125	215	210	340	280	60	105	172	166	212	140	218	797	156
125-200/75/W	125	125	215	210	340	280	60	105	172	166	212	140	218	835	165
125-250/75/W	125	125	230	215	450	350	63	110	180	223	275	140	218	855	200
125-250/110/W	125	125	230	245	450	350	63	110	180	223	275	140	264	963	255
125-315/150/W	125	125	230	245	450	350	63	110	180	223	275	140	264	1007	294
125-315/185/W	125	125	230	245	450	350	63	110	180	223	275	140	279	1029	329
125-315/220/W	125	125	230	245	450	350	63	110	180	223	275	140	279	1067	347
125-315/300/W	125	125	230	251	450	350	63	110	180	223	275	140	317	1138	396
150-200/55/W	150	150	230	225	450	350	75	130	212	182	253	140	218	827	189
150-200/75/W	150	150	230	225	450	350	75	130	212	182	253	140	218	865	198
150-200/110/W	150	150	230	255	450	350	75	130	212	182	253	140	264	973	253
150-250/110/W	150	150	230	240	450	350	75	130	212	193	255	140	264	958	259
150-250/150/W	150	150	230	240	450	350	75	130	212	193	255	140	264	1002	281
150-315/185/W	150	150	230	254	450	350	78	135	222	215	257	140	279	1038	335
150-315/220/W	150	150	230	254	450	350	78	135	222	215	257	140	279	1076	353
150-315/300/W	150	150	230	254	450	350	78	135	222	215	257	140	317	1141	399
150-315/370/W	150	150	230	284	450	350	78	135	222	215	257	140	408	1260	557

NOTE: Pumps supplied with flanges according to EN 1092-2 as standard. For flanges dimensions see drawing.

LNES-4p50-en_a_td

LNE..H

(e-LNE WITH HYDROVAR)

LNE..H SERIES (e-LNE WITH HYDROVAR)

Background and context

For all pumping needs in commercial or residential building and in industry applications, the demand for intelligent pumping systems is constantly growing. Controlled systems offer many advantages: reduced operating costs for the lifetime of the pump, lower environmental impact, longer lifetime of piping systems and networks.

For this reason, Lowara has developed the LNE..H: an intelligent pumping system which assures high level performance with energy consumption tailored to the system's demand.

Benefits of e-LNE with HYDROVAR

Saving: LNE..H transforms the LNE pumps into variable speed intelligent pumping systems. Thanks to the HYDROVAR, the speed of each pump varies so as to maintain a constant flow, a constant pressure, or a differential pressure. In doing so, at any point in time, the pump only receives the energy required. This in turns allows for considerable savings, especially for systems that have varying loads throughout the day.

Easy installation and space-saving: LNE..H saves time and space during installation. The Hydrovar is delivered already mounted on the motor (for models up to 22kW). The hydrovar is kept cool by the motor fan and does not require a control panel. In order to function, only fuses on the supply line are needed (Check your local electrical installation regulations). A wall-mounted HYDROVAR version is available for higher power outputs (up to 45 kW).

Standard motors: LNE..H models are fitted with three-phase standard TEFC motors with insulation class 155 (F).

Key Features of the Hydrovar

- **No need for additional pressure sensors:**
The LNE..H is fitted with a pressure transmitter or differential pressure transmitters, depending on the application.
- **No need for special pumps or motors.**
- **No need for bypass or safety systems:**
The LNE..H will immediately switch off when demand drops to zero or when it exceeds maximum pump capacity; thus making installation of additional safety devices unnecessary.
- **Anti-condensation device:**
The LNE..H is fitted with anti-condensation devices which switch on when the pump is in standby in order to prevent condensation forming in the unit.



LNE..H SERIES (e-LNE WITH HYDROVAR)

The basic function of the HYDROVAR device is to control the pump to meet the system demands.

HYDROVAR performs these functions by:

- 1) Measuring the system pressure or flow via a transmitter mounted on the pump's delivery side.
- 2) Calculating the motor speed to maintain the correct flow or pressure.
- 3) Sending out a signal to the pump to start the motor, increase speed, decrease speed or stop.
- 4) In the case of multiple pump installations, HYDROVAR will automatically provide for the cyclic changeover of the pumps' starting sequence.

In addition to these basic functions, HYDROVAR can perform controls only manageable by the most advanced computerized control systems. Some examples are:

- Stop the pump(s) at zero demand.
- Stop the pump(s) in case of water failure on the suction side (protection against dry running).
- Stop the pump if the required delivery exceeds the pump's capacity (protection against cavitation caused by excessive demand), or automatically switch on the next pump in a multiple series.
- Protect the pump and motor from over-voltage, under-voltage, overload, and earth fault.
- Vary the pump speed: acceleration and deceleration time.
- Compensate for increased flow resistance at high flow rates.
- Conduct automatic tests at set intervals.
- Monitor the converter and motor operating hours.
- Display all functions on an LCD in different languages (Italian, English, French, German, Spanish, Portuguese, Dutch).
- Send a signal to a remote control system which is proportional to the pressure and frequency.
- Communicate with another HYDROVAR or control system via an RS 485 interface.

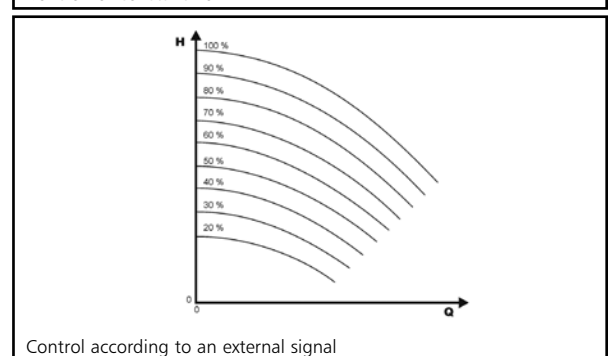
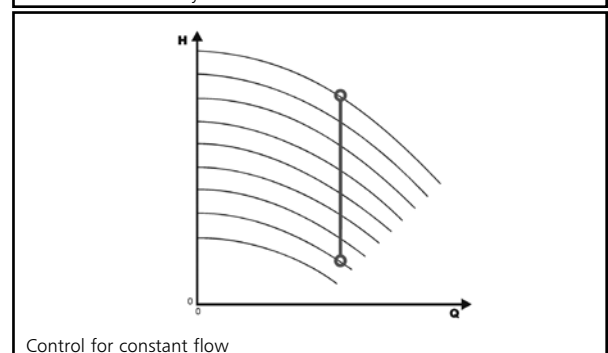
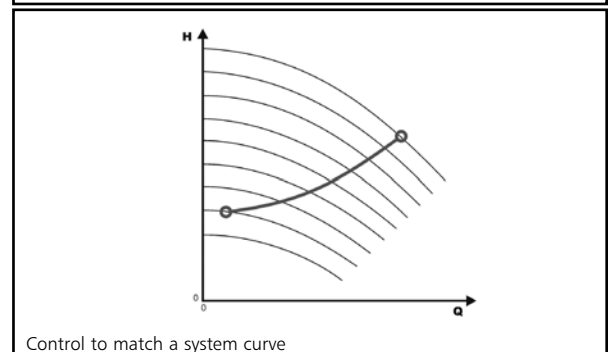
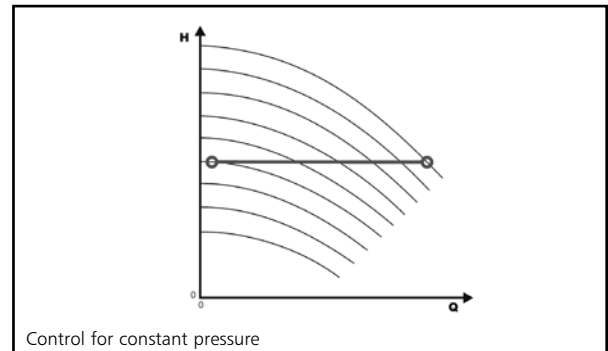

ACCESSORIES

LNE SERIES

ROUND THREADED COUNTERFLANGES ACCORDING TO EN 1092-1

DN	ø C	DIMENSIONS (mm)				HOLES		PN
		ø A	B	ø D	H	ø F	N°	
40	Rp 1½	110	14	150	19	18	4	16
50	Rp 2	125	16	165	24	18	4	16
65	Rp 2½	145	16	185	23	18	4	16
80	Rp 3	160	17	200	27	18	8	16
100	Rp 4	180	18	220	31	18	8	16

fc-fct-ctf-tonde-f-en_a_td

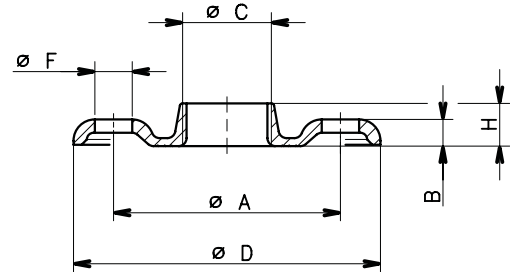

04430_B_DD

LNE SERIES

ROUND WELD COUNTERFLANGES ACCORDING TO EN 1092-1

DN	ø C	DIMENSIONS (mm)			HOLES		PN
		ø A	B	ø D	ø F	N°	
65	77	145	18	185	18	4	16
80	90	160	20	200	18	8	16
100	115,5	180	22	220	18	8	16
125	141,5	210	22	250	18	8	16
150	170,5	240	24	285	22	8	16

fc-fct-ctf-tonde-s-en_a_td

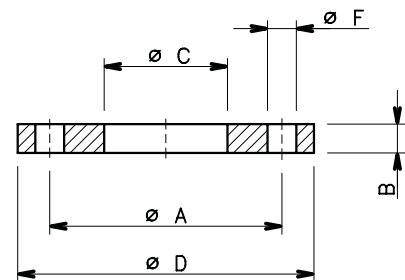

04431_A_DD

LNE 40, 50, 65, 80, 100 SERIES MOUNTING BASE

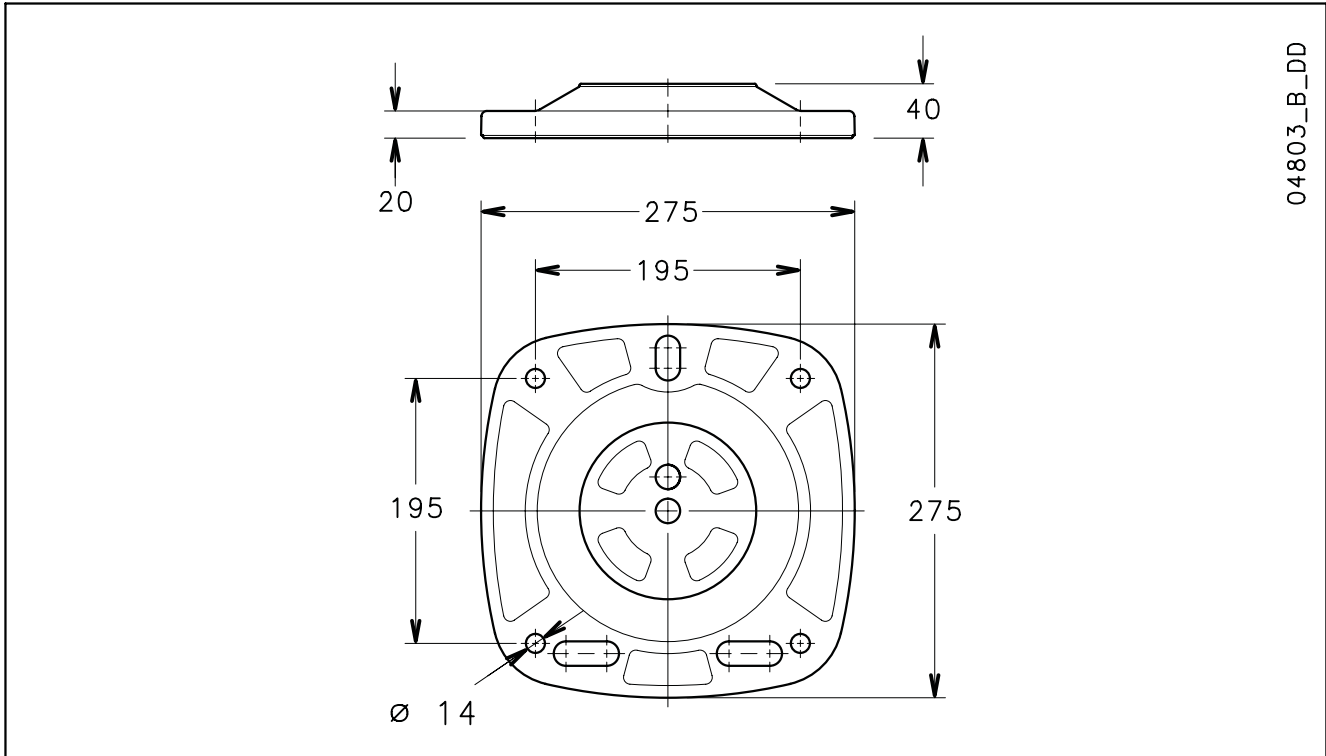

LNE 125, 150 SERIES MOUNTING BASE

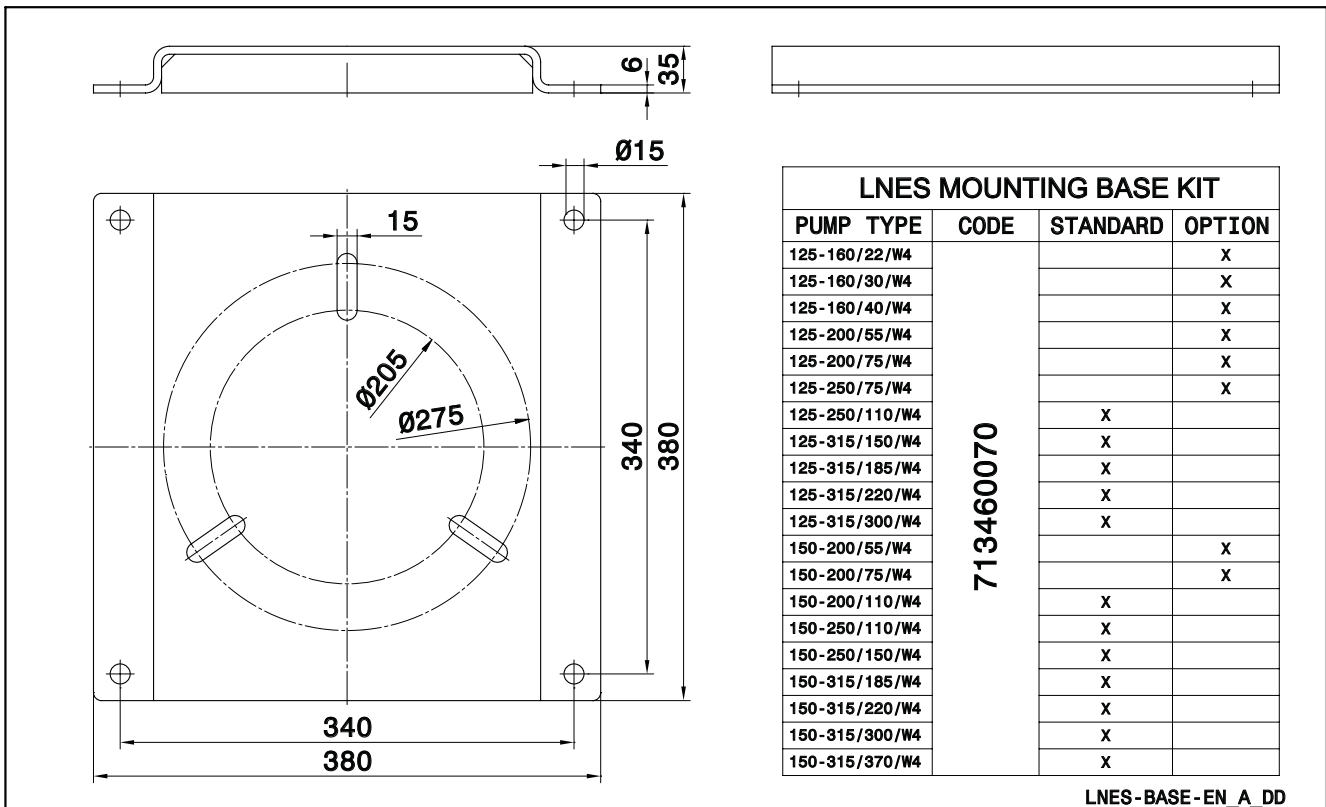

REPORTS AND DECLARATIONS

REPORTS AND DECLARATIONS

i) Test reports

- a) **Factory Test Report** (Lowara identity code: 1A)
(not available for all pump types; contact Customer Service in advance)
- Test report compiled at the end of the assembly line, including flow-head performance test (ISO 9906:2012 – Grade 3B) and tightness test.
- b) **Audit Test Report** (Lowara identity code: 1B)
- Test report for electric pumps compiled in the test room, comprising flow-head-pump input-pump efficiency performance test (ISO 9906:2012 – Grade 3B)
- c) **NPSH Test Report** (Lowara identity code: 1A / CTF-NP)
(unavailable for submerged or submergible pumps)
- Test report for electric pumps compiled in the test room, comprising flow-NPSH performance test (ISO 9906:2012 – Grade 3B)
- d) **Noise Test Report** (Lowara identity code: 1A / CTF-RM)
(unavailable for submerged pumps)
- Report indicating sound pressure and power measurements (EN ISO 20361, EN ISO 11203, EN ISO 4871) using the
• intensimetric (EN ISO 9614-1, EN ISO 9614-2), or
• phonometric method.
- e) **Vibration Test Report**
(unavailable for submerged or submergible pumps)
- Report indicating vibration measurements (ISO 10816-1)

ii) Declaration of product conformity with the technical requirements indicated in the order

- a) **EN 10204:2004 - type 2.1** (Lowara identity code: CTF-21)
- does not include test results on supplied or similar products.
- b) **EN 10204:2004 - type 2.2** (Lowara identity code: CTF-22)
- includes test results (materials certificates) on similar products.
- c) **EN 10204:2004 - type 3.1** (Lowara identity code: 1A / CTF-31 or 1B / CTF-31)
- includes test report (*Factory Test Report* or *Audit Test Report*), list of materials, EC Declaration of Conformity (in addition to the one accompanying the product), certificates / declarations concerning materials in contact with water.

iii) Issue of a further EC Declaration of Conformity,

- in addition to the one accompanying the product, it comprises references to European law and the main technical standards (e.g.: MD 2006/42/EC, EMCD 2004/108/EC, ErP 2009/125/EC).

N.B.: if the request is made after receipt of the product, communicate the code (name) and serial number (date + progressive number).

iv) Manufacturer's declaration of conformity

- relative to one of more types of products without indicating specific codes and serial numbers.

v) Other certificates and/or documentation on request

- subject to availability or feasibility.

vi) Duplication of certificates and/or documentation on request

- subject to availability or feasibility.

TECHNICAL APPENDIX

NPSH

The minimum operating values that can be reached at the pump suction end are limited by the onset of cavitation.

Cavitation is the formation of vapour-filled cavities within liquids where the pressure is locally reduced to a critical value, or where the local pressure is equal to, or just below the vapour pressure of the liquid.

The vapour-filled cavities flow with the current and when they reach a higher pressure area the vapour contained in the cavities condenses. The cavities collide, generating pressure waves that are transmitted to the walls. These, being subjected to stress cycles, gradually become deformed and yield due to fatigue. This phenomenon, characterized by a metallic noise produced by the hammering on the pipe walls, is called incipient cavitation.

The damage caused by cavitation may be magnified by electrochemical corrosion and a local rise in temperature due to the plastic deformation of the walls. The materials that offer the highest resistance to heat and corrosion are alloy steels, especially austenitic steel. The conditions that trigger cavitation may be assessed by calculating the total net suction head, referred to in technical literature with the acronym NPSH (Net Positive Suction Head).

The NPSH represents the total energy (expressed in m.) of the liquid measured at suction under conditions of incipient cavitation, excluding the vapour pressure (expressed in m.) that the liquid has at the pump inlet.

To find the static height h_z at which to install the machine under safe conditions, the following formula must be verified:

$$h_p + h_z \geq (NPSH_r + 0.5) + h_f + h_{pv} \quad \textcircled{1}$$

where:

- h_p** is the absolute pressure applied to the free liquid surface in the suction tank, expressed in m. of liquid; h_p is the quotient between the barometric pressure and the specific weight of the liquid.
- h_z** is the suction lift between the pump axis and the free liquid surface in the suction tank, expressed in m.; h_z is negative when the liquid level is lower than the pump axis.
- h_f** is the flow resistance in the suction line and its accessories, such as: fittings, foot valve, gate valve, elbows, etc.
- h_{pv}** is the vapour pressure of the liquid at the operating temperature, expressed in m. of liquid. h_{pv} is the quotient between the P_v vapour pressure and the liquid's specific weight.
- 0,5** is the safety factor.

The maximum possible suction head for installation depends on the value of the atmospheric pressure (i.e. the elevation above sea level at which the pump is installed) and the temperature of the liquid.

To help the user, with reference to water temperature (4° C) and to the elevation above sea level, the following tables show the drop in hydraulic pressure head in relation to the elevation above sea level, and the suction loss in relation to temperature.

Water temperature (°C)	20	40	60	80	90	110	120
Suction loss (m)	0,2	0,7	2,0	5,0	7,4	15,4	21,5

Elevation above sea level (m)	500	1000	1500	2000	2500	3000
Suction loss (m)	0,55	1,1	1,65	2,2	2,75	3,3

Friction loss is shown in the tables at pages 102-103 of this catalogue. To reduce it to a minimum, especially in cases of high suction head (over 4-5 m.) or within the operating limits with high flow rates, we recommend using a suction line having a larger diameter than that of the pump's suction port. It is always a good idea to position the pump as close as possible to the liquid to be pumped.

Make the following calculation:

Liquid: water at ~15°C $\gamma = 1 \text{ kg/dm}^3$

Flow rate required: 25 m³/h

Head for required delivery: 70 m.

Suction lift: 3,5 m.

The selection is an 33SV3G075T pump whose NPSH required value is, at 25 m³/h, of 2 m.

For water at 15 °C

$$h_p = P_a / \gamma = 10,33\text{m}, h_{pv} = P_v / \gamma = 0,174\text{m} (0,01701 \text{ bar})$$

The H_f flow resistance in the suction line with foot valves is ~ 1,2 m.

By substituting the parameters in formula $\textcircled{1}$ with the numeric values above, we have:

$$10,33 + (-3,5) \geq (2 + 0,5) + 1,2 + 0,17$$

from which we have: 6,8 > 3,9

The relation is therefore verified.

VAPOUR PRESSURE

VAPOUR PRESSURE p_s AND ρ DENSITY OF WATER TABLE

t °C	T K	p_s bar	ρ kg/dm ³	t °C	T K	p_s bar	ρ kg/dm ³	t °C	T K	p_s bar	ρ kg/dm ³
0	273,15	0,00611	0,9998	55	328,15	0,15741	0,9857	120	393,15	1,9854	0,9429
1	274,15	0,00657	0,9999	56	329,15	0,16511	0,9852	122	395,15	2,1145	0,9412
2	275,15	0,00706	0,9999	57	330,15	0,17313	0,9846	124	397,15	2,2504	0,9396
3	276,15	0,00758	0,9999	58	331,15	0,18147	0,9842	126	399,15	2,3933	0,9379
4	277,15	0,00813	1,0000	59	332,15	0,19016	0,9837	128	401,15	2,5435	0,9362
5	278,15	0,00872	1,0000	60	333,15	0,1992	0,9832	130	403,15	2,7013	0,9346
6	279,15	0,00935	1,0000	61	334,15	0,2086	0,9826	132	405,15	2,867	0,9328
7	280,15	0,01001	0,9999	62	335,15	0,2184	0,9821	134	407,15	3,041	0,9311
8	281,15	0,01072	0,9999	63	336,15	0,2286	0,9816	136	409,15	3,223	0,9294
9	282,15	0,01147	0,9998	64	337,15	0,2391	0,9811	138	411,15	3,414	0,9276
10	283,15	0,01227	0,9997	65	338,15	0,2501	0,9805	140	413,15	3,614	0,9258
11	284,15	0,01312	0,9997	66	339,15	0,2615	0,9799	145	418,15	4,155	0,9214
12	285,15	0,01401	0,9996	67	340,15	0,2733	0,9793	155	428,15	5,433	0,9121
13	286,15	0,01497	0,9994	68	341,15	0,2856	0,9788	160	433,15	6,181	0,9073
14	287,15	0,01597	0,9993	69	342,15	0,2984	0,9782	165	438,15	7,008	0,9024
15	288,15	0,01704	0,9992	70	343,15	0,3116	0,9777	170	443,15	7,920	0,8973
16	289,15	0,01817	0,9990	71	344,15	0,3253	0,9770	175	448,15	8,924	0,8921
17	290,15	0,01936	0,9988	72	345,15	0,3396	0,9765	180	453,15	10,027	0,8869
18	291,15	0,02062	0,9987	73	346,15	0,3543	0,9760	185	458,15	11,233	0,8815
19	292,15	0,02196	0,9985	74	347,15	0,3696	0,9753	190	463,15	12,551	0,8760
20	293,15	0,02337	0,9983	75	348,15	0,3855	0,9748	195	468,15	13,987	0,8704
21	294,15	0,24850	0,9981	76	349,15	0,4019	0,9741	200	473,15	15,550	0,8647
22	295,15	0,02642	0,9978	77	350,15	0,4189	0,9735	205	478,15	17,243	0,8588
23	296,15	0,02808	0,9976	78	351,15	0,4365	0,9729	210	483,15	19,077	0,8528
24	297,15	0,02982	0,9974	79	352,15	0,4547	0,9723	215	488,15	21,060	0,8467
25	298,15	0,03166	0,9971	80	353,15	0,4736	0,9716	220	493,15	23,198	0,8403
26	299,15	0,03360	0,9968	81	354,15	0,4931	0,9710	225	498,15	25,501	0,8339
27	300,15	0,03564	0,9966	82	355,15	0,5133	0,9704	230	503,15	27,976	0,8273
28	301,15	0,03778	0,9963	83	356,15	0,5342	0,9697	235	508,15	30,632	0,8205
29	302,15	0,04004	0,9960	84	357,15	0,5557	0,9691	240	513,15	33,478	0,8136
30	303,15	0,04241	0,9957	85	358,15	0,5780	0,9684	245	518,15	36,523	0,8065
31	304,15	0,04491	0,9954	86	359,15	0,6011	0,9678	250	523,15	39,776	0,7992
32	305,15	0,04753	0,9951	87	360,15	0,6249	0,9671	255	528,15	43,246	0,7916
33	306,15	0,05029	0,9947	88	361,15	0,6495	0,9665	260	533,15	46,943	0,7839
34	307,15	0,05318	0,9944	89	362,15	0,6749	0,9658	265	538,15	50,877	0,7759
35	308,15	0,05622	0,9940	90	363,15	0,7011	0,9652	270	543,15	55,058	0,7678
36	309,15	0,05940	0,9937	91	364,15	0,7281	0,9644	275	548,15	59,496	0,7593
37	310,15	0,06274	0,9933	92	365,15	0,7561	0,9638	280	553,15	64,202	0,7505
38	311,15	0,06624	0,9930	93	366,15	0,7849	0,9630	285	558,15	69,186	0,7415
39	312,15	0,06991	0,9927	94	367,15	0,8146	0,9624	290	563,15	74,461	0,7321
40	313,15	0,07375	0,9923	95	368,15	0,8453	0,9616	295	568,15	80,037	0,7223
41	314,15	0,07777	0,9919	96	369,15	0,8769	0,9610	300	573,15	85,927	0,7122
42	315,15	0,08198	0,9915	97	370,15	0,9094	0,9602	305	578,15	92,144	0,7017
43	316,15	0,09639	0,9911	98	371,15	0,9430	0,9596	310	583,15	98,70	0,6906
44	317,15	0,09100	0,9907	99	372,15	0,9776	0,9586	315	588,15	105,61	0,6791
45	318,15	0,09582	0,9902	100	373,15	1,0133	0,9581	320	593,15	112,89	0,6669
46	319,15	0,10086	0,9898	102	375,15	1,0878	0,9567	325	598,15	120,56	0,6541
47	320,15	0,10612	0,9894	104	377,15	1,1668	0,9552	330	603,15	128,63	0,6404
48	321,15	0,11162	0,9889	106	379,15	1,2504	0,9537	340	613,15	146,05	0,6102
49	322,15	0,11736	0,9884	108	381,15	1,3390	0,9522	350	623,15	165,35	0,5743
50	323,15	0,12335	0,9880	110	383,15	1,4327	0,9507	360	633,15	186,75	0,5275
51	324,15	0,12961	0,9876	112	385,15	1,5316	0,9491	370	643,15	210,54	0,4518
52	325,15	0,13613	0,9871	114	387,15	1,6362	0,9476	374,15	647,30	221,20	0,3154
53	326,15	0,14293	0,9862	116	389,15	1,7465	0,9460				
54	327,15	0,15002	0,9862	118	391,15	1,8628	0,9445				

G-at_npsb_sc

TABLE OF FLOW RESISTANCE IN 100 m OF STRAIGHT CAST IRON PIPELINE (HAZEN-WILLIAMS FORMULA C=100)

FLOW RATE		NOMINAL DIAMETER in mm and inches																		
m ³ /h	l/min		15	20	25	32	40	50	65	80	100	125	150	175	200	250	300	350	400	
			1/2"	3/4"	1"	1 1/4"	1 1/2"	2	2 1/2"	3"	4"	5"	6"	7"	8"	10"	12"	14"	16"	
0,6	10	v	0,94	0,53	0,34	0,21	0,13													
		hr	16	3,94	1,33	0,40	0,13													
0,9	15	v	1,42	0,80	0,51	0,31	0,20													
		hr	33,9	8,35	2,82	0,85	0,29													
1,2	20	v	1,89	1,06	0,68	0,41	0,27	0,17												
		hr	57,7	14,21	4,79	1,44	0,49	0,16												
1,5	25	v	2,36	1,33	0,85	0,52	0,33	0,21												
		hr	87,2	21,5	7,24	2,18	0,73	0,25												
1,8	30	v	2,83	1,59	1,02	0,62	0,40	0,25												
		hr	122	30,1	10,1	3,05	1,03	0,35												
2,1	35	v	3,30	1,86	1,19	0,73	0,46	0,30												
		hr	162	40,0	13,5	4,06	1,37	0,46												
2,4	40	v	2,12	1,36	0,83	0,53	0,34	0,20												
		hr		51,2	17,3	5,19	1,75	0,59												
3	50	v		2,65	1,70	1,04	0,66	0,42	0,25											
		hr		77,4	26,1	7,85	2,65	0,89	0,25											
3,6	60	v		3,18	2,04	1,24	0,80	0,51	0,30											
		hr		108	36,6	11,0	3,71	1,25	0,35											
4,2	70	v		3,72	2,38	1,45	0,93	0,59	0,35											
		hr		144	48,7	14,6	4,93	1,66	0,46											
4,8	80	v		4,25	2,72	1,66	1,06	0,68	0,40											
		hr		185	62,3	18,7	6,32	2,13	0,59											
5,4	90	v			3,06	1,87	1,19	0,76	0,45	0,30										
		hr			77,5	23,3	7,85	2,65	0,74	0,27										
6	100	v			3,40	2,07	1,33	0,85	0,50	0,33										
		hr			94,1	28,3	9,54	3,22	0,90	0,33										
7,5	125	v			4,25	2,59	1,66	1,06	0,63	0,41										
		hr			142	42,8	14,4	4,86	1,36	0,49										
9	150	v				3,11	1,99	1,27	0,75	0,50	0,32									
		hr				59,9	20,2	6,82	1,90	0,69	0,23									
10,5	175	v				3,63	2,32	1,49	0,88	0,58	0,37									
		hr				79,7	26,9	9,07	2,53	0,92	0,31									
12	200	v				4,15	2,65	1,70	1,01	0,66	0,42									
		hr				102	34,4	11,6	3,23	1,18	0,40									
15	250	v				5,18	3,32	2,12	1,26	0,83	0,53	0,34								
		hr				154	52,0	17,5	4,89	1,78	0,60	0,20								
18	300	v					3,98	2,55	1,51	1,00	0,64	0,41								
		hr					72,8	24,6	6,85	2,49	0,84	0,28								
24	400	v					5,31	3,40	2,01	1,33	0,85	0,54	0,38							
		hr					124	41,8	11,66	4,24	1,43	0,48	0,20							
30	500	v					6,63	4,25	2,51	1,66	1,06	0,68	0,47							
		hr					187	63,2	17,6	6,41	2,16	0,73	0,30							
36	600	v						5,10	3,02	1,99	1,27	0,82	0,57	0,42						
		hr						88,6	24,7	8,98	3,03	1,02	0,42	0,20						
42	700	v						5,94	3,52	2,32	1,49	0,95	0,66	0,49						
		hr						118	32,8	11,9	4,03	1,36	0,56	0,26						
48	800	v						6,79	4,02	2,65	1,70	1,09	0,75	0,55						
		hr						151	42,0	15,3	5,16	1,74	0,72	0,34						
54	900	v						7,64	4,52	2,99	1,91	1,22	0,85	0,62						
		hr						188	52,3	19,0	6,41	2,16	0,89	0,42						
60	1000	v							5,03	3,32	2,12	1,36	0,94	0,69	0,53					
		hr							63,5	23,1	7,79	2,63	1,08	0,51	0,27					
75	1250	v							6,28	4,15	2,65	1,70	1,18	0,87	0,66					
		hr							96,0	34,9	11,8	3,97	1,63	0,77	0,40					
90	1500	v							7,54	4,98	3,18	2,04	1,42	1,04	0,80					
		hr							134	48,9	16,5	5,57	2,29	1,08	0,56					
105	1750	v							8,79	5,81	3,72	2,38	1,65	1,21	0,93					
		hr							179	65,1	21,9	7,40	3,05	1,44	0,75					
120	2000	v								6,63	4,25	2,72	1,89	1,39	1,06	0,68				
		hr								83,3	28,1	9,48	3,90	1,84	0,96	0,32				
150	2500	v								8,29	5,31	3,40	2,36	1,73	1,33	0,85				
		hr								126	42,5	14,3	5,89	2,78	1,45	0,49				
180	3000	v								6,37	4,08	2,83	2,08	1,59	1,02	0,71				
		hr								59,5	20,1	8,26	3,90	2,03	0,69	0,28				
210	3500	v								7,43	4,76	3,30	2,43	1,86	1,19	0,83				
		hr								79,1	26,7	11,0	5,18	2,71	0,91	0,38				
240	4000	v								8,49	5,44	3,77	2,77	2,12	1,36	0,94				
		hr								101	34,2	14,1	6,64	3,46	1,17	0,48				
300	5000	v									6,79	4,72	3,47	2,65	1,70	1,18				
		hr									51,6	21,2	10,0	5,23	1,77	0,73				
360	6000	v									8,15	5,66	4,16	3,18	2,04	1,42				
		hr									72,3	29,8	14,1	7,33	2,47	1,02				
420	7000	v										6,61	4,85	3,72	2,38	1,65	1,21			
		hr										39,6	18,7	9,75	3,29	1,35	0,64			
480	8000	v										7,55	5,55	4,25	2,72	1,89	1,39			
		hr										50,7	23,9	12,49	4,21	1,73	0,82			
540	9000	v										8,49	6,24	4,78	3,06	2,12	1,56	1,19		
		hr										63,0	29,8	15,5	5,24	2,16	1,02	0,53		
600	10000	v											6,93	5,31	3,40	2,36	1,73	1,33		

FLOW RESISTANCE TABLE OF FLOW RESISTANCE IN BENDS, VALVES AND GATES

The flow resistance is calculated using the equivalent pipeline length method according to the table below:

ACCESSORY TYPE	DN											
	25	32	40	50	65	80	100	125	150	200	250	300
	Equivalent pipeline length (m)											
45° bend	0,2	0,2	0,4	0,4	0,6	0,6	0,9	1,1	1,5	1,9	2,4	2,8
90° bend	0,4	0,6	0,9	1,1	1,3	1,5	2,1	2,6	3,0	3,9	4,7	5,8
90° smooth bend	0,4	0,4	0,4	0,6	0,9	1,1	1,3	1,7	1,9	2,8	3,4	3,9
Union tee or cross	1,1	1,3	1,7	2,1	2,6	3,2	4,3	5,3	6,4	7,5	10,7	12,8
Gate	-	-	-	0,2	0,2	0,2	0,4	0,4	0,6	0,9	1,1	1,3
Non return valve	1,1	1,5	1,9	2,4	3,0	3,4	4,7	5,9	7,4	9,6	11,8	13,9

G-a-pcv-en_a_th

The table is valid for the Hazen Williams coefficient $C=100$ (cast iron pipework);

for steel pipework, multiply the values by 1,41;

for stainless steel, copper and coated cast iron pipework, multiply the values by 1,85;

When the **equivalent pipeline length** has been determined, the flow resistance is obtained from the table of flow resistance.

The values given are guideline values which are bound to vary slightly according to the model, especially for gate valves and non-return valves, for which it is a good idea to check the values supplied by manufacturers.

VOLUMETRIC CAPACITY

Litres per minute l/min	Cubic metres per hour m ³ /h	Cubic feet per hour ft ³ /h	Cubic feet per minute ft ³ /min	Imperial gallon per minute Imp. gal/min	U.S. gallon per minute US gal/min
1,000	0,0600	2,1189	0,0353	0,2200	0,2642
16,6667	1,0000	35,3147	0,5886	3,6662	4,4029
0,4719	0,0283	1,0000	0,0167	0,1038	0,1247
28,3168	1,6990	60,0000	1,0000	6,2288	7,4805
4,5461	0,2728	9,6326	0,1605	1,0000	1,2009
3,7854	0,2271	8,0208	0,1337	0,8327	1,0000

PRESSURE AND HEAD

Newton per square metre N/m ²	kilo Pascal kPa	bar bar	Pound force per square inch psi	Metre of water m H ₂ O	Millimetre of mercury mm Hg
1,0000	0,0010	1 x 10 ⁻⁵	1,45 x 10 ⁻⁴	1,02 x 10 ⁻⁴	0,0075
1 000,0000	1,0000	0,0100	0,1450	0,1020	7,5006
1 x 10 ⁵	100,0000	1,0000	14,5038	10,1972	750,0638
6 894,7570	6,8948	0,0689	1,0000	0,7031	51,7151
9 806,6500	9,8067	0,0981	1,4223	1,0000	73,5561
133,3220	0,1333	0,0013	0,0193	0,0136	1,0000

LENGTH

Millimetre mm	Centimetre cm	Metre m	Inch in	Foot ft	Yard yd
1,0000	0,1000	0,0010	0,0394	0,0033	0,0011
10,0000	1,0000	0,0100	0,3937	0,0328	0,0109
1 000,0000	100,0000	1,0000	39,3701	3,2808	1,0936
25,4000	2,5400	0,0254	1,0000	0,0833	0,0278
304,8000	30,4800	0,3048	12,0000	1,0000	0,3333
914,4000	91,4400	0,9144	36,0000	3,0000	1,0000

VOLUME

Cubic metre m ³	Litre L	Millilitre ml	Imperial gallon imp. gal.	U.S. gallon US gal.	Cubic foot ft ³
1,0000	1 000,0000	1 x 10 ⁶	219,9694	264,1720	35,3147
0,0010	1,0000	1 000,0000	0,2200	0,2642	0,0353
1 x 10 ⁻⁶	0,0010	1,0000	2,2 x 10 ⁻⁴	2,642 x 10 ⁻⁴	3,53 x 10 ⁻⁵
0,0045	4,5461	4 546,0870	1,0000	1,2009	0,1605
0,0038	3,7854	3 785,4120	0,8327	1,0000	0,1337
0,0283	28,3168	28 316,8466	6,2288	7,4805	1,0000

TEMPERATURE

Water	Kelvin K	Celsius °C	Fahrenheit °F	$^{\circ}\text{F} = ^{\circ}\text{C} \times \frac{9}{5} + 32$ $^{\circ}\text{C} = (^{\circ}\text{F} - 32) \times \frac{5}{9}$
icing	273,1500	0,0000	32,0000	
boiling	373,1500	100,0000	212,0000	

G-at_pp-en_b_sc

FURTHER PRODUCT SELECTION AND DOCUMENTATION Xylect™



Xylect™ is pump solution selection software with an extensive online database of product information across the entire Lowara, and Vogel range of pumps and related products, with multiple search options and helpful project management facilities. The system holds up-to-date product information on thousands of products and accessories.

The possibility to search by applications and the detailed information output given makes it easy to make the optimal selection without having detailed knowledge about the Lowara and Vogel products.

The search can be made by:

- Application
- Product type
- Duty point

Xylect™ gives a detailed output:

- List with search results
- Performance curves (flow, head, power, efficiency, NPSH)
- Motor data
- Dimensional drawings
- Options
- Data sheet printouts
- Document downloads incl dxf files

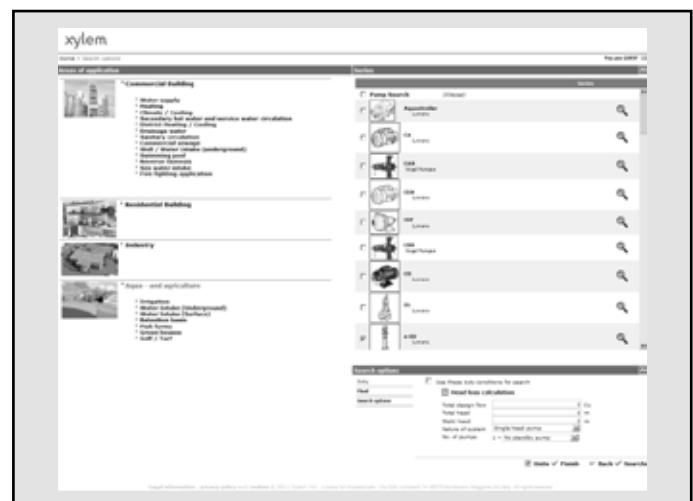

The search by application guides users not familiar with the product range to the right choice.

FURTHER PRODUCT SELECTION AND DOCUMENTATION

Xylect™

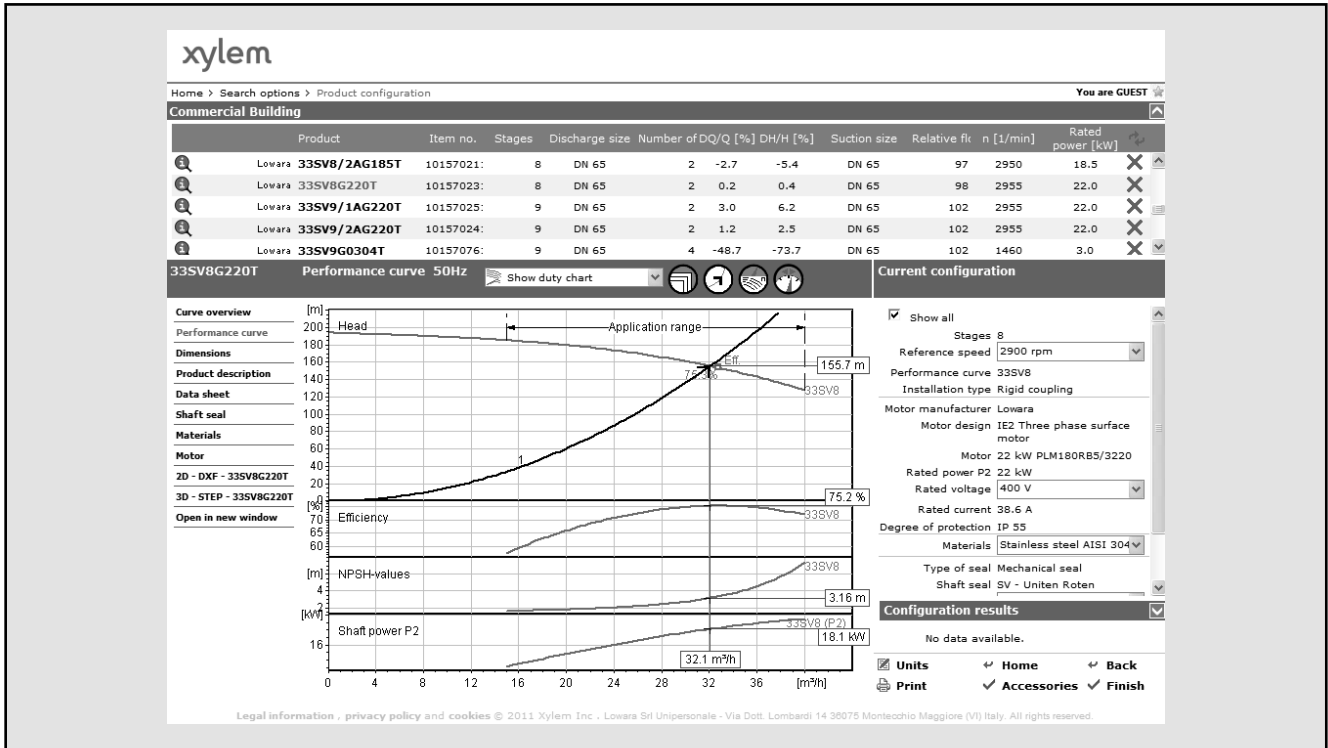

The detailed output makes it easy to select the optimal pump from the given alternatives.

The best way to work with Xylect™ is to create a personal account. This makes it possible to:

- Set own standard units
- Create and save projects
- Share projects with other Xylect™ users

Every user has a My Xylect space, where all projects are saved.

For more information about Xylect™ please contact our sales network or visit www.xylect.com.

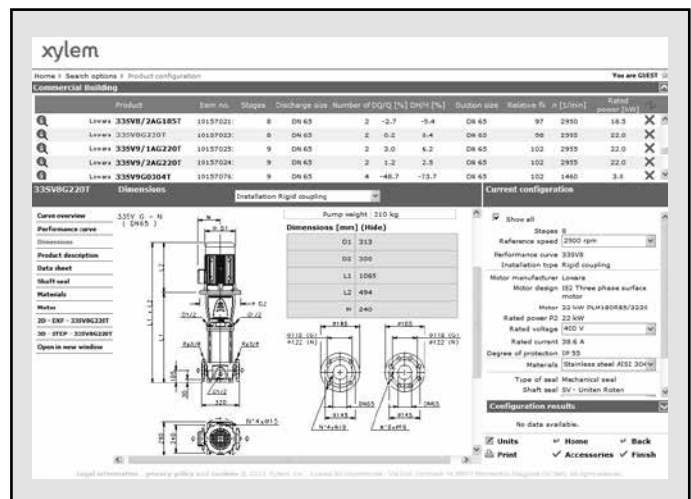

Dimensional drawings appear on the screen and can be downloaded in dxf format.

Xylem |'zīləm|

- 1) The tissue in plants that brings water upward from the roots;
- 2) a leading global water technology company.

We're approximately 12,500 people unified in a common purpose: creating innovative solutions to meet our world's water needs. Developing new technologies that will improve the way water is used, conserved, and re-used in the future is central to our work. We move, treat, analyze, and return water to the environment, and we help people use water efficiently, in their homes, buildings, factories and farms. In more than 150 countries, we have strong, long-standing relationships with customers who know us for our powerful combination of leading product brands and applications expertise, backed by a legacy of innovation.

For more information on how Xylem can help you, go to xylem.com.



Legal head office
Xylem Water Solutions Italia Srl

Via Gioacchino Rossini 1/A
20020 - Lainate (MI) - Italy
Tel. (+39) 02 90358.1
Fax (+39) 02 9019990
www.xylemwatersolutions.com

For information and technical support
Xylem Service Italia Srl

Via Dottor Vittorio Lombardi 14
36075 - Montecchio Maggiore (VI) - Italy
Tel. (+39) 0444 707111
Fax (+39) 0444 491043
www.lowara.com

Xylem Water Solutions Italia Srl reserves the right to make modification without prior notice.
Lowara, Xylem are trademarks of Xylem Inc. or one of its subsidiaries
© 2014 Xylem, Inc.