

SVH with HYDROVAR® (HVL range)



SVH SERIES (e-SV WITH HYDROVAR)

Background and context

For all pumping needs in commercial or residential building and in industry applications, the demand for intelligent pumping systems is constantly growing. Controlled systems offer many advantages: reduced operating costs for the lifetime of the pump, lower environmental impact, longer lifetime of piping systems and networks.

For this reason, Lowara has developed the SVH: an intelligent pumping system which assures high level performance with energy consumption tailored to the system's demand.

Benefits of e-SVH with HYDROVAR

Saving: SVH transforms the e-SV pumps into variable speed intelligent pumping systems. Thanks to the HYDROVAR, the speed of each pump varies so as to maintain a constant flow, a constant pressure, or a differential pressure. In doing so, at any point in time, the pump only receives the energy required. This in turns allows for considerable savings, especially for systems that have varying loads throughout the day.

Easy installation and space-saving: SVH saves time and space during installation. The Hydrovar is delivered already mounted on the motor (for models up to 22kW). The hydrovar is kept cool by the motor fan and does not require a control panel. In order to function, only fuses on the supply line are needed (Check your local electrical installation regulations). A wall-mounted HYDROVAR version is available for higher power outputs (up to 45 kW).

Standard motors: SVH models are fitted with three-phase standard TEFC motors with insulation class 155 (F) and IE3 efficiency level from 0,75 to 22 kW.

Identification code:

SVH models are identified by the letter "**H**" and the last two characters.

Examples:

3SV**H**16F015T /**2**

3SV**H**16F015T /**3X**

3SV**H**16F015T /**4C**

H = with integrated HYDROVAR

/2 = HYDROVAR HVL**2**.015 1~ 208-240 V (50/60 Hz)

/3 = HYDROVAR HVL**3**.015 3~ 208-240 V (50/60 Hz)

/4 = HYDROVAR HVL**4**.015 3~ 380-460 V (50/60 Hz)

Other options:

W = Wi-fi Card.

C = Premium Card.

X = Wi-fi Card and Premium Card.

Key Features of the HYDROVAR

- **No need for additional pressure sensors:**

The SVH is fitted with a pressure transmitter or differential pressure transmitters, depending on the application (normally the pressure transducers are fitted on the flanges).

- **No need for special pumps or motors.**

- **SVH is already pre-wired.**

- **No need for IN LINE filters.**

HYDROVAR already includes the THDi filter embedded as standard.

- **No need for bypass or safety systems:**

The SVH will immediately switch off when demand drops to zero or when it exceeds maximum pump capacity; thus making installation of additional safety devices unnecessary.

- **Anti-condensation device:**

The HYDROVAR is fitted with anti-condensation devices which switch on when the pump is in standby in order to prevent condensation forming in the unit.



SVH SERIES (e-SV WITH HYDROVAR)

The basic function of the HYDROVAR device is to control the pump to meet the system demands.

HYDROVAR performs these functions by:

- 1) Measuring the system pressure or flow via a transmitter mounted on the pump's delivery side.
- 2) Calculating the motor speed to maintain the correct flow or pressure.
- 3) Sending out a signal to the pump to start the motor, increase speed, decrease speed or stop.
- 4) In the case of multiple pump installations, HYDROVAR will automatically provide for the cyclic changeover of the pumps' starting sequence.

In addition to these basic functions, HYDROVAR can perform controls only manageable by the most advanced computerized control systems. Some examples are:

- Stop the pump(s) at zero demand.
- Stop the pump(s) in case of water failure on the suction side (protection against dry running).
- Stop the pump if the required delivery exceeds the pump's capacity (protection against cavitation caused by excessive demand), or automatically switch on the next pump in a multiple series.
- Protect the pump and motor from over-voltage, under-voltage, overload, and earth fault.
- Vary the pump speed: acceleration and deceleration time.
- Compensate for increased flow resistance at high flow rates.
- Conduct automatic tests at set intervals.
- Monitor the converter and motor operating hours.
- Display the energy consumption (kWh).
- Display all functions on an LCD in different languages (Italian, English, French, German, Spanish, Portuguese, Dutch, etc...).
- Send a signal to a remote control system which is proportional to the pressure and frequency.
- Communicate with external control system via Modbus (RS 485 interface) and Bacnet as standard.

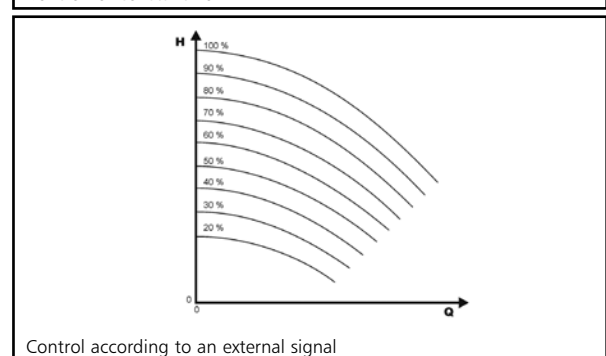
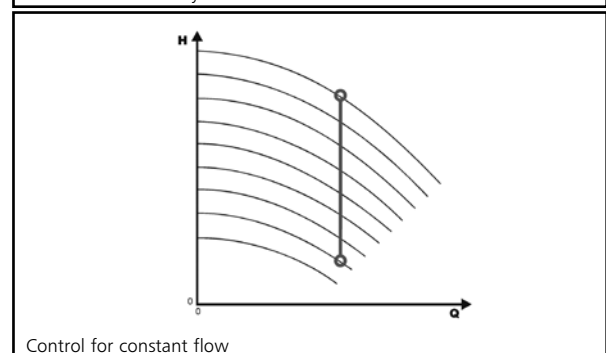
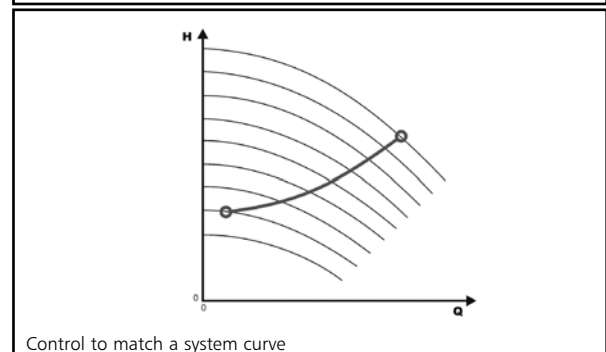
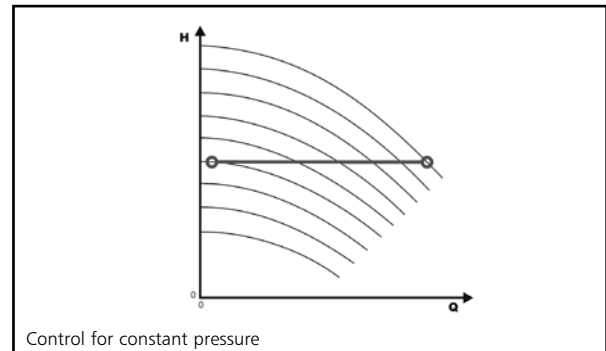

HYDROVAR HVL IDENTIFICATION CODE

H V L 4 . 0 7 5 - A 0 0 1 0

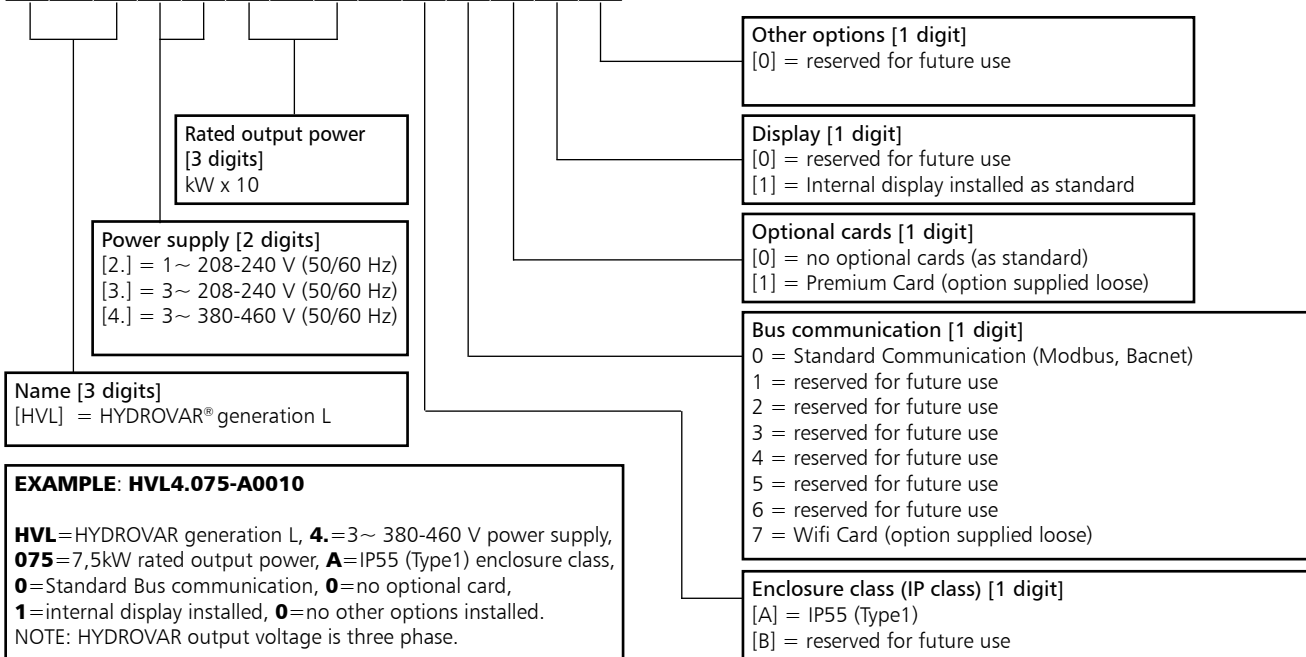

DIMENSIONS AND WEIGHTS



TYPE	MODELS			DIMENSIONS (mm)				WEIGHT Kg
	/2	/3	/4	L	B	H	X	
SIZE A	HVL2.015 ÷ 2.022	HVL3.015 ÷ 3.022	HVL4.015 ÷ 4.040	216	205	170	243	5,6
SIZE B	HVL2.030 ÷ 2.040	HVL3.030 ÷ 3.055	HVL4.055 ÷ 4.110	276	265	185	305	10,5
SIZE C	-	HVL3.075 ÷ 3.110	HVL4.150 ÷ 4.220	366	337	200	407	15,6

HVL_dim-en_b_td

HYDROVAR HVL EMC COMPATIBILITY

EMC requirements

HYDROVAR fulfills the product standard EN61800-3:2004 + A1:2012, which defines categories (C1 to C4) for device application areas.

Depending on the motor cable length, a classification of HYDROVAR by category (based on EN61800-3) is reported in the following tables:

HVL	HYDROVAR classification by categories based on EN61800-3
2.015 ÷ 2.040	C1 (*)
3.015 ÷ 3.110	C2 (*)
4.015 ÷ 4.220	C2 (*)

(*) 0,75 motor cable length; contact Xylem for further information

En-Rev_A

CARD

Premium Card HYDROVAR (optional)

For the e-SVH series, the Premium Card comes fitted as option on the standalone HYDROVAR.

This allows to control up to five fix speed pumps via an external panel.

The Premium Card will allow additional features listed below:

- 2 additional Analog Inputs
- 2 Analog Outputs
- 1 additional digital input
- 5 relays.

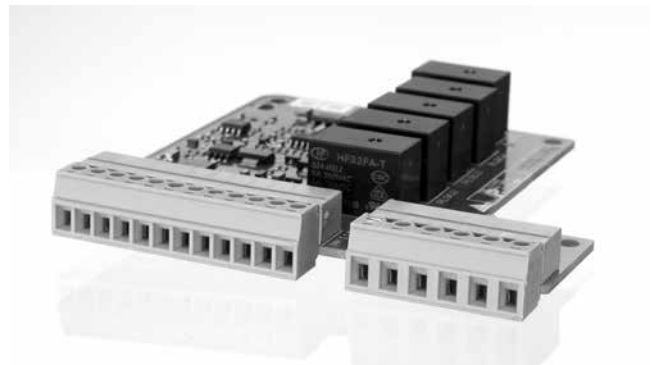

Wi-Fi Card HYDROVAR (optional)

With the WiFi card fitted in the HYDROVAR, the unit can will allow you to be connected to a wireless network.

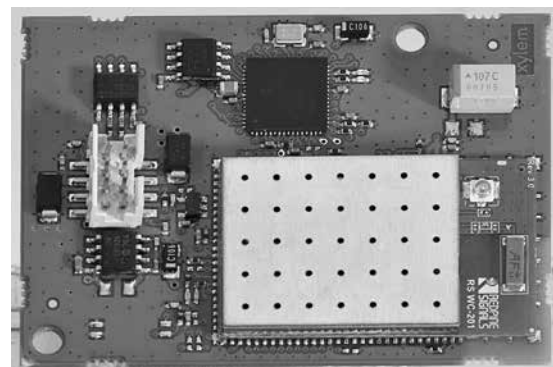

OPTIONAL COMPONENTS

Sensors

The following sensors are available for HYDROVAR:

- Pressure-transducer
- Differential pressure-transducer
- Temperature-sensor
- Flow indicator (orifice plate, inductive flow meter)
- Level-sensor.

SVH SERIES

LIST OF MODELS AT 50 Hz, 2 POLES

PUMP TYPE	kW	VERSION		
		/2	/3	/4
		1~ 230V	3~ 230V	3~ 400V
1SVH15	0,75	A	A	A
1SVH22	1,1	A	A	A
1SVH30	1,5	A	A	A
1SVH37	2,2	A	A	A
3SVH08	0,75	A	A	A
3SVH12	1,1	A	A	A
3SVH16	1,5	A	A	A
3SVH21	2,2	A	A	A
3SVH25	2,2	A	A	A
3SVH29	3	B	B	A
3SVH33	3	B	B	A
5SVH05	0,75	A	A	A
5SVH08	1,1	A	A	A
5SVH11	1,5	A	A	A
5SVH14	2,2	A	A	A
5SVH16	2,2	A	A	A
5SVH21	3	B	B	A
5SVH28	4	B	B	A
5SVH33	5,5	-	B	B
10SVH04	1,5	A	A	A
10SVH06	2,2	A	A	A
10SVH08	3	B	B	A
10SVH11	4	B	B	A
10SVH15	5,5	-	B	B
10SVH20	7,5	-	C	B
10SVH21	11	-	C	B
15SVH02	2,2	A	A	A
15SVH03	3	B	B	A
15SVH05	4	B	B	A
15SVH07	5,5	-	B	B
15SVH09	7,5	-	C	B
15SVH13	11	-	C	B
15SVH17	15	-	-	C
22SVH01	1,1	A	A	A
22SVH03	3	B	B	A
22SVH04	4	B	B	A
22SVH05	5,5	-	B	B
22SVH07	7,5	-	C	B
22SVH10	11	-	C	B
22SVH14	15	-	-	C
22SVH17	18,5	-	-	C

PUMP TYPE	kW	VERSION		
		/2	/3	/4
		1~ 230V	3~ 230V	3~ 400V
33SVH1	3	B	B	A
33SVH2	5,5	-	B	B
33SVH3	7,5	-	C	B
33SVH4	11	-	C	B
33SVH5	15	-	-	C
33SVH6	15	-	-	C
33SVH7	18,5	-	-	C
46SVH1	4	B	B	A
46SVH2	7,5	-	C	B
46SVH3	11	-	C	B
46SVH4	15	-	-	C
46SVH6	22	-	-	C
66SVH1	5,5	-	B	B
66SVH2	11	-	C	B
66SVH3	18,5	-	-	C
66SVH4	22	-	-	C
92SVH1	7,5	-	C	B
92SVH2	15	-	-	C
92SVH3	22	-	-	C

SVH-HVL_models-2p50-en_b_sc

LEGEND

A, B, C : are the mechanical size of HYDROVAR, refer to "HYDROVAR DIMENSIONS AND WEIGHTS" table in previous pages.

SVH SERIES ELECTRICAL DATA TABLE AT 50 Hz, 2 POLES

PUMP TYPE	kW	MEI ≥ (1)	INPUT CURRENT (2) (A)		
			/2	/3	/4
			1 ~ 230V	3 ~ 230V	3 ~ 400V
1SVH15	0,75	0,7	4,0	2,4	1,4
1SVH22	1,1	0,7	5,8	3,5	2,1
1SVH30	1,5	0,7	8,0	4,8	2,8
1SVH37	2,2	0,7	11,7	7,1	4,1
3SVH08	0,75	0,7	4,0	2,4	1,4
3SVH12	1,1	0,7	5,8	3,5	2,1
3SVH16	1,5	0,7	8,0	4,8	2,8
3SVH21	2,2	0,7	11,7	7,1	4,1
3SVH25	2,2	0,7	11,7	7,1	4,1
3SVH29	3	0,7	15,9	9,6	5,6
3SVH33	3	0,7	15,9	9,6	5,6
5SVH05	0,75	0,7	4,0	2,4	1,4
5SVH08	1,1	0,7	5,8	3,5	2,1
5SVH11	1,5	0,7	8,0	4,8	2,8
5SVH14	2,2	0,7	11,7	7,1	4,1
5SVH16	2,2	0,7	11,7	7,1	4,1
5SVH21	3	0,7	15,9	9,6	5,6
5SVH28	4	0,7	21,2	12,6	7,3
5SVH33	5,5	0,7	-	17,3	10,1
10SVH04	1,5	0,7	8,0	4,8	2,8
10SVH06	2,2	0,7	11,7	7,1	4,1
10SVH08	3	0,7	15,9	9,6	5,6
10SVH11	4	0,7	21,2	12,6	7,3
10SVH15	5,5	0,7	-	17,3	10,1
10SVH20	7,5	0,7	-	23,1	13,7
10SVH21	11	0,7	-	34,0	19,4
15SVH02	2,2	0,7	11,7	7,1	4,1
15SVH03	3	0,7	15,9	9,6	5,6
15SVH05	4	0,7	21,2	12,6	7,3
15SVH07	5,5	0,7	-	17,3	10,1
15SVH09	7,5	0,7	-	23,1	13,7
15SVH13	11	0,7	-	34,0	19,4
15SVH17	15	0,7	-	-	26,1
22SVH01	1,1	0,7	5,8	3,5	2,1
22SVH03	3	0,7	15,9	9,6	5,6
22SVH04	4	0,7	21,2	12,6	7,3
22SVH05	5,5	0,7	-	17,3	10,1
22SVH07	7,5	0,7	-	23,1	13,7
22SVH10	11	0,7	-	34,0	19,4
22SVH14	15	0,7	-	-	26,1
22SVH17	18,5	0,7	-	-	32,1

PUMP TYPE	kW	MEI ≥ (1)	INPUT CURRENT (2) (A)		
			/2	/3	/4
			1 ~ 230V	3 ~ 230V	3 ~ 400V
33SVH1	3	0,7	15,9	9,6	5,6
33SVH2	5,5	0,7	-	17,3	10,1
33SVH3	7,5	0,7	-	23,1	13,7
33SVH4	11	0,7	-	34,0	19,4
33SVH5	15	0,7	-	-	26,1
33SVH6	15	0,7	-	-	26,1
33SVH7	18,5	0,7	-	-	32,1
46SVH1	4	0,7	21,2	12,6	7,3
46SVH2	7,5	0,7	-	23,1	13,7
46SVH3	11	0,7	-	34,0	19,4
46SVH4	15	0,7	-	-	26,1
46SVH6	22	0,7	-	-	38,1
66SVH1	5,5	0,7	-	17,3	10,1
66SVH2	11	0,7	-	34,0	19,4
66SVH3	18,5	0,7	-	-	32,1
66SVH4	22	0,7	-	-	38,1
92SVH1	7,5	0,6	-	23,1	13,7
92SVH2	15	0,6	-	-	26,1
92SVH3	22	0,6	-	-	38,1

SVH-HVL-2p50-en_a_te

Q = DELIVERY	Pp = POWER
H = HEAD	np = EFFICIENCY
(1) Values referred to operation at 2900 min ⁻¹ (50 Hz).	
(2) Nominal values referred to operation at 2900 min ⁻¹ (50 Hz).	

For hydraulic performance values, consult the standard e-SV™ catalogue

1, 3, 5, 10, 15, 22SV Value referred to versions F, T, R, N, V, C, K. P version excluded.

33, 46SV Value referred to the G and N versions with PN ≤ 25 bar (2500 kPa). G and N versions with PN > 25 bar (2500 kPa) and P version excluded.

66, 92SV Value referred to the G, N versions. P version excluded.

1, 3, 5, 10, 15, 22SVH SERIES HYDRAULIC PERFORMANCE TABLE AT 50 Hz, 2 POLES

PUMP TYPE	RATED POWER		Q = DELIVERY														
			l/min 0	12	20	25	30	35	40	45	50	60	73	100	120	141	
			m ³ /h 0	0,7	1,2	1,5	1,8	2,1	2,4	2,7	3,0	3,6	4,4	6,0	7,2	8,5	
kW		HP	H = TOTAL HEAD IN METRES OF COLUMN OF WATER														
1SVH15	0,75	1	90,9	90,5	85,6	79,3	70,1	58,1	43,1								
1SVH22	1,1	1,5	134,6	134,1	127,4	118,1	104,4	86,1	63,5								
1SVH30	1,5	2	181,7	181,3	172,6	160,1	141,2	115,7	83,9								
1SVH37	2,2	3	225,9	224,9	216,1	201,9	179,3	148,1	108,7								
3SVH08	0,75	1	60,0		59,1	58,2	57,0	55,4	53,4	51,0	48,1	40,7	27,5				
3SVH12	1,1	1,5	89,6		87,8	86,4	84,5	82,1	79,1	75,5	71,1	59,9	40,1				
3SVH16	1,5	2	119,9		117,8	116,1	113,6	110,5	106,5	101,6	95,8	80,9	54,2				
3SVH21	2,2	3	159,3		156,9	154,6	151,4	147,3	142,1	135,7	128,0	108,5	73,6				
3SVH25	2,2	3	188,5		186,1	183,3	179,3	174,1	167,6	159,7	150,3	126,6	84,8				
3SVH29	3	4	219,3		216,0	212,8	208,3	202,6	195,3	186,4	175,7	148,6	100,2				
3SVH33	3	4	248,5		245,3	241,5	236,2	229,3	220,7	210,2	197,7	166,3	111,2				
5SVH05	0,75	1	38,0						36,4	36,0	35,5	34,5	32,9	28,2	23,5	17,1	
5SVH08	1,1	1,5	60,1						57,6	57,0	56,2	54,6	51,8	44,1	36,2	25,8	
5SVH11	1,5	2	82,8						79,3	78,4	77,5	75,2	71,4	60,7	49,9	35,6	
5SVH14	2,2	3	105,7						102,0	100,9	99,6	96,6	91,7	77,8	64,0	46,3	
5SVH16	2,2	3	120,5						115,9	114,6	113,1	109,6	103,9	87,8	72,1	51,8	
5SVH21	3	4	157,9						152,0	150,3	148,3	143,6	136,1	114,9	94,2	67,6	
5SVH28	4	5,5	211,5						204,2	201,9	199,4	193,3	183,4	155,5	128,0	92,7	
5SVH33	5,5	7,5	249,2						241,0	238,4	235,5	228,4	216,9	184,2	151,9	110,3	

Hydraulic performances in compliance with ISO 9906:2012 - Grade 3B (ex ISO 9906:1999 - Annex A).

1-5svh-2p50-en_c_th

PUMP TYPE	RATED POWER		Q = DELIVERY														
			l/min 0	83,34	100	133	170	183,34	233	270	330	350	400	430	460	483,33	
			m ³ /h 0	5,0	6,0	8,0	10,2	11,0	14,0	16,2	19,8	21,0	24,0	25,8	27,6	29,0	
kW		HP	H = TOTAL HEAD IN METRES OF COLUMN OF WATER														
10SVH04	1,5	2	47,7	44,2	43,0	39,9	34,8	32,6	21,7								
10SVH06	2,2	3	71,8	66,8	65,0	60,4	53,1	49,8	33,9								
10SVH08	3	4	95,3	88,9	86,5	80,1	70,2	65,7	44,5								
10SVH11	4	5,5	129,6	121,3	118,1	109,6	96,3	90,3	62,1								
10SVH15	5,5	7,5	179,5	167,9	163,4	151,6	132,8	124,3	83,9								
10SVH20	7,5	10	240,6	226,0	220,3	205,0	180,2	168,9	114,3								
10SVH21	11	15	253,6	241,0	235,5	220,2	195,0	183,5	127,5								
15SVH02	2,2	3	28,7			26,7	25,9	25,5	23,9	22,4	18,9	17,4	13,1				
15SVH03	3	4	43,3			40,4	39,1	38,6	36,2	33,8	28,7	26,5	20,1				
15SVH05	4	5,5	72,7			67,8	65,8	65,0	61,0	57,1	48,7	45,2	34,9				
15SVH07	5,5	7,5	101,9			94,5	91,9	90,8	85,7	80,6	69,4	64,7	50,5				
15SVH09	7,5	10	131,9			124,4	121,0	119,6	112,8	106,1	91,5	85,5	67,4				
15SVH13	11	15	191,3			179,2	174,5	172,5	163,1	153,7	133,1	124,5	98,6				
15SVH17	15	20	251,6			237,3	231,4	228,9	216,9	205,0	178,4	167,3	133,6				
22SVH01	1,1	1,5	14,7					13,5	12,7	12,0	10,4	9,7	7,7	6,3	4,7	3,4	
22SVH03	3	4	45,4					42,2	40,4	38,5	34,5	32,8	27,8	24,2	20,2	16,6	
22SVH04	4	5,5	60,9					56,8	54,4	51,9	46,6	44,4	37,9	33,1	27,7	23,0	
22SVH05	5,5	7,5	76,0					70,9	67,9	64,9	58,3	55,6	47,4	41,4	34,7	28,8	
22SVH07	7,5	10	108,5					103,1	99,4	95,7	87,2	83,7	73,1	65,3	56,5	48,8	
22SVH10	11	15	155,4					148,2	143,1	137,8	125,9	120,9	105,8	94,8	82,3	71,3	
22SVH14	15	20	216,6					207,7	200,9	193,7	177,4	170,4	149,4	133,9	116,1	100,6	
22SVH17	18,5	25	263,5					252,8	244,7	236,0	216,2	207,8	182,3	163,6	142,0	123,2	

Hydraulic performances in compliance with ISO 9906:2012 - Grade 3B (ex ISO 9906:1999 - Annex A).

10-22svh-2p50-en_c_th

33, 46, 66, 92SVH SERIES HYDRAULIC PERFORMANCE TABLE AT 50 Hz, 2 POLES

PUMP TYPE	RATED POWER		Q = DELIVERY										
			l/min 0	250	300	367	417	500	583	667	750	900	1000
	kW	HP	m ³ /h 0	15	18	22	25	30	35	40	45	54	60
H = TOTAL HEAD METRES COLUMN OF WATER													
33SVH1	3	4	23,8	21,7	21,2	20	20	17,8	15,5	12,7			
33SVH2	5,5	7,5	47,8	45	44,1	43	41	39	35	29,9			
33SVH3	7,5	10	71,5	67,4	66,0	64	62	58	52,0	44,6			
33SVH4	11	15	95,9	91,1	90	87	85	80	73	63,1			
33SVH5	15	20	120,4	114,9	113	110	107	101	92	80,5			
33SVH6	15	20	145,6	139	137	133	129	121	110	96,1			
33SVH7	18,5	25	170,3	162,8	160	156	152	142	130	113,3			
46SVH1	4	5,5	27,2			24	23,5	22,5	21,4	19,9	18,2	14,3	10,8
46SVH2	7,5	10	52,6			48,5	47,7	46,1	44,2	41,7	38,7	31,4	25,1
46SVH3	11	15	80,8			74,3	73	71	68	65	60	50	40,7
46SVH4	15	20	107,3			99,8	98	96	92	87	82	68	55,9
46SVH6	22	30	161			149,9	148	144	139	132	124	104	86

Hydraulic performances in compliance with ISO 9906:2012 - Grade 3B (ex ISO 9906:1999 - Annex A).

33-46svh-2p50-en_b_th

PUMP TYPE	RATED POWER		Q = DELIVERY												
			l/min 0	500	600	700	750	900	1000	1200	1300	1417	1600	1800	2000
	kW	HP	m ³ /h 0	30	36	42	45	54	60	72	78	85	96	108	120
H = TOTAL HEAD METRES COLUMN OF WATER															
66SVH1	5,5	7,5	29,2	25,8	24,8	23,8	23,3	21,8	20,7	17,9	16,1	13,5			
66SVH2	11	15	60,4	55,7	54,4	52,8	52	49,3	47,1	42	38,9	34,7			
66SVH3	18,5	25	91,4	84,7	83	81	79	75	72	64	60	53,5			
66SVH4	22	30	121,6	112,5	110	107	105	100	96	86	79	70,8			
92SVH1	7,5	10	33,5				28,7	27,2	26,2	24,3	23,3	22,2	20,2	17,6	14,3
92SVH2	15	20	67,8				58,2	55	53	49,5	47,6	45,2	41,4	36,3	29,6
92SVH3	22	30	102,2				88,2	84	81	76	73	69	63	56	46,3

Hydraulic performances in compliance with ISO 9906:2012 - Grade 3B (ex ISO 9906:1999 - Annex A).

66-92svh-2p50-en_b_th

1SVH SERIES

DIMENSIONS AND WEIGHTS AT 50 Hz, 2 POLES

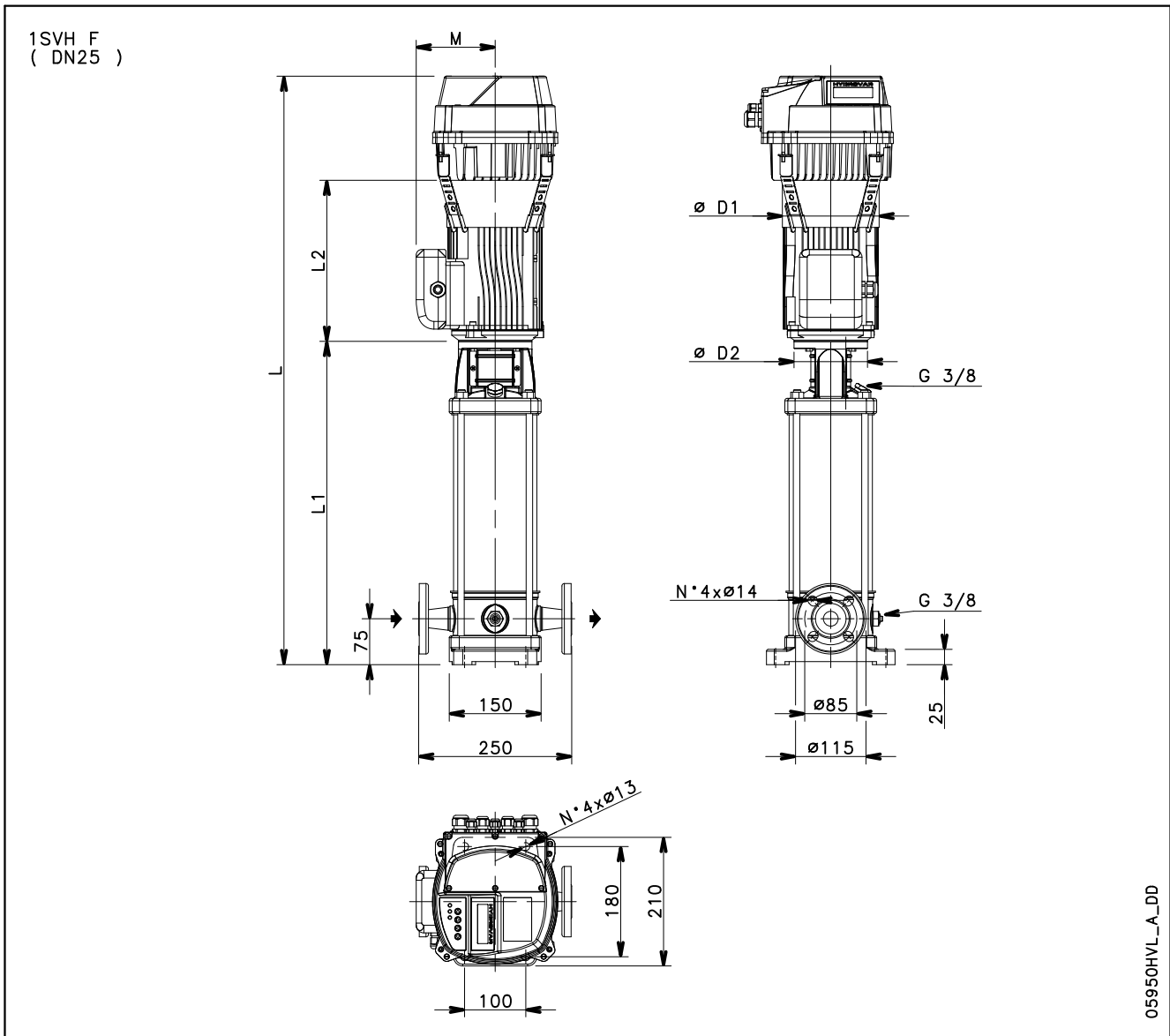

PUMP TYPE	MOTOR		DIMENSIONS (mm)					L			WEIGHT (kg)		
			L1	L2	M	D1	D2	/2	/3	/4	/2	/3	/4
				3 ~	3 ~	3 ~		1 ~ 230V	3 ~ 230V	3 ~ 400V	1 ~ 230V	3 ~ 230V	3 ~ 400V
1SVH15	0,75	80	528	263	129	155	120	961	961	961	29,1	29,1	29,1
1SVH22	1,1	80	668	263	129	155	120	1101	1101	1101	34,2	34,2	34,2
1SVH30	1,5	90	838	263	129	155	140	1271	1271	1271	39,6	39,6	39,6
1SVH37	2,2	90	978	298	134	174	140	1446	1446	1446	45,4	45,4	45,4

3SVH SERIES DIMENSIONS AND WEIGHTS AT 50 Hz, 2 POLES

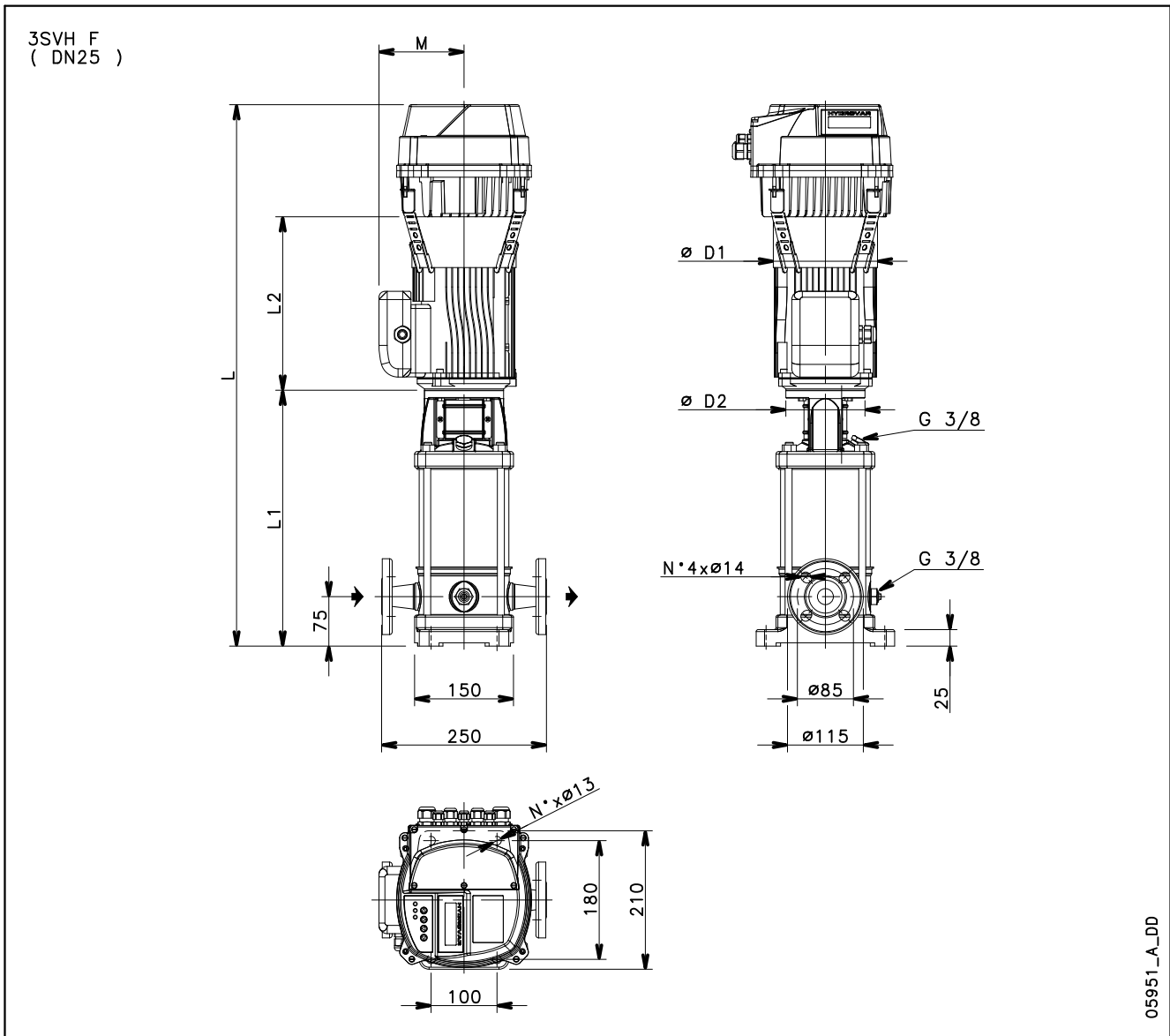

PUMP TYPE	MOTOR		DIMENSIONS (mm)					L			WEIGHT (kg)		
			L1	L2	M	D1	D2	/2	/3	/4	/2	/3	/4
								1 ~ 230V	3 ~ 230V	3 ~ 400V	1 ~ 230V	3 ~ 230V	3 ~ 400V
3SVH08	0,75	80	388	263	129	155	120	821	821	821	26,5	26,5	26,5
3SVH12	1,1	80	468	263	129	155	120	901	901	901	30,3	30,3	30,3
3SVH16	1,5	90	558	263	129	155	140	991	991	991	33,8	33,8	33,8
3SVH21	2,2	90	658	298	134	174	140	1126	1126	1126	40,8	40,8	40,8
3SVH25	2,2	90	738	298	134	174	140	1206	1206	1206	42,4	42,4	42,4
3SVH29	3	100	828	298	134	174	160	1311	1311	1296	53,9	53,9	49,0
3SVH33	3	100	908	298	134	174	160	1391	1391	1376	55,5	55,5	50,6

3svh-HVL-2p50-en_a_td

5SVH SERIES DIMENSIONS AND WEIGHTS AT 50 Hz, 2 POLES

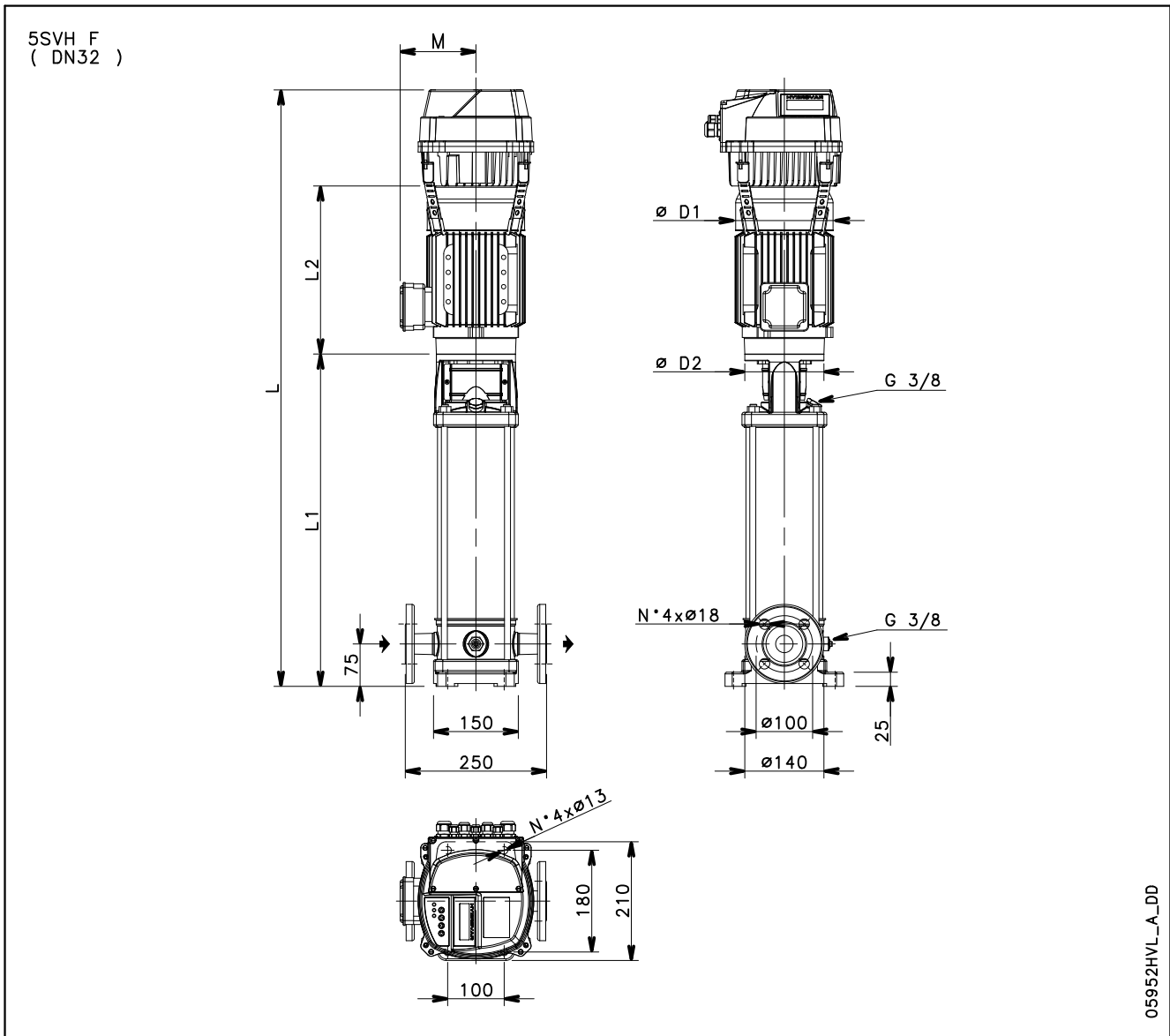

05952HVL_A_DD

PUMP TYPE	MOTOR		DIMENSIONS (mm)					L			WEIGHT (kg)		
			L1	L2	M	D1	D2	/2	/3	/4	/2	/3	/4
				3 ~	3 ~	3 ~		1 ~ 230V	3 ~ 230V	3 ~ 400V	1 ~ 230V	3 ~ 230V	3 ~ 400V
5SVH05	0,75	80	353	263	129	155	120	786	786	786	25,7	25,7	25,7
5SVH08	1,1	80	428	263	129	155	120	861	861	861	29,1	29,1	29,1
5SVH11	1,5	90	513	263	129	155	140	946	946	946	32,6	32,6	32,6
5SVH14	2,2	90	588	298	134	174	140	1056	1056	1056	38,8	38,8	38,8
5SVH16	2,2	90	638	298	134	174	140	1106	1106	1106	39,8	39,8	39,8
5SVH21	3	100	773	298	134	174	160	1256	1256	1241	50,9	50,9	46,0
5SVH28	4	112	948	319	154	197	160	1452	1452	1437	59,9	59,9	55,0
5SVH33	5,5	132	1093	375	168	214	300	-	1653	1653	-	77,6	77,6

3svh-HVL-2p50-en_a_td

10SVH SERIES DIMENSIONS AND WEIGHTS AT 50 Hz, 2 POLES

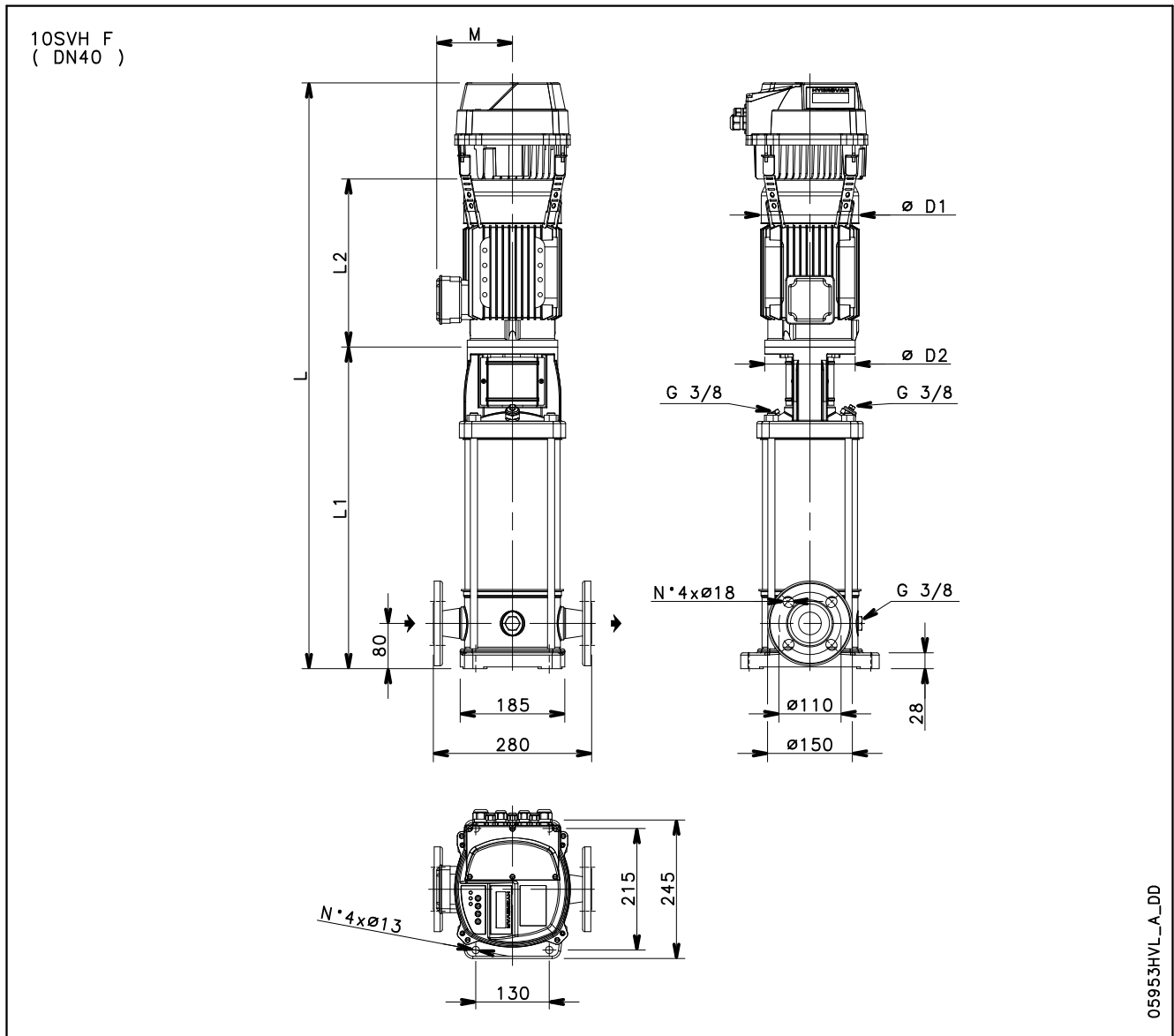

PUMP TYPE	MOTOR		DIMENSIONS (mm)					L			WEIGHT (kg)		
			L1	L2	M	D1	D2	/2	/3	/4	/2	/3	/4
				3 ~	3 ~	3 ~		1 ~ 230V	3 ~ 230V	3 ~ 400V	1 ~ 230V	3 ~ 230V	3 ~ 400V
10SVH04	1,5	90	431	263	129	155	140	864	864	864	36,6	36,6	36,6
10SVH06	2,2	90	495	298	134	174	140	963	963	963	43,5	43,5	43,5
10SVH08	3	100	569	298	134	174	160	1052	1052	1037	53,9	53,9	49,0
10SVH11	4	112	665	319	154	197	160	1169	1169	1154	62,5	62,5	57,6
10SVH15	5,5	132	860	375	168	214	300	-	1420	1420	-	83,5	83,5
10SVH20	7,5	132	1020	367	191	256	300	-	1587	1572	-	111,6	106,5
10SVH21	11	160	1082	428	191	256	350	-	1710	1695	-	128,6	123,5

10svh-HVL-2p50-en_a_td

15SVH SERIES DIMENSIONS AND WEIGHTS AT 50 Hz, 2 POLES

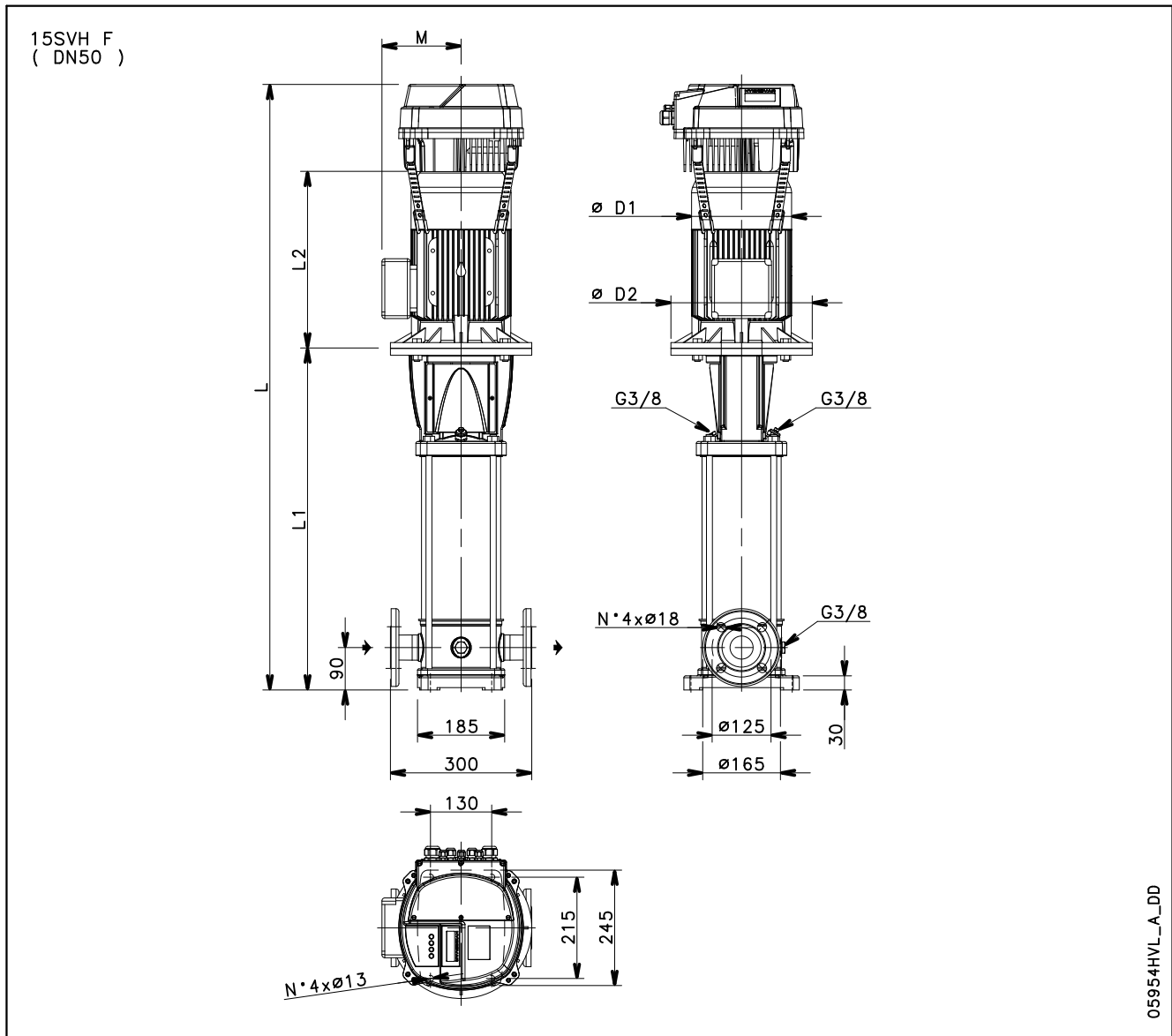

PUMP TYPE	MOTOR		DIMENSIONS (mm)					L			WEIGHT (kg)		
			L1	L2	M	D1	D2	/2	/3	/4	/2	/3	/4
								1 ~ 230V	3 ~ 230V	3 ~ 400V	1 ~ 230V	3 ~ 230V	3 ~ 400V
15SVH02	2,2	90	409	298	134	174	140	877	877	877	40,3	40,3	40,3
15SVH03	3	100	467	298	134	174	160	950	950	935	50,5	50,5	45,6
15SVH05	4	112	563	319	154	197	160	1067	1067	1052	58,4	58,4	53,5
15SVH07	5,5	132	726	375	168	214	300	-	1286	1286	-	78,5	78,5
15SVH09	7,5	132	822	367	191	256	300	-	1389	1374	-	105,6	100,5
15SVH13	11	160	1044	428	191	256	350	-	1672	1657	-	127,6	122,5
15SVH17	15	160	1236	494	240	313	350	-	-	1930	-	-	164,6

15svh-HVL-2p50-en_a_td

22SVH SERIES DIMENSIONS AND WEIGHTS AT 50 Hz, 2 POLES

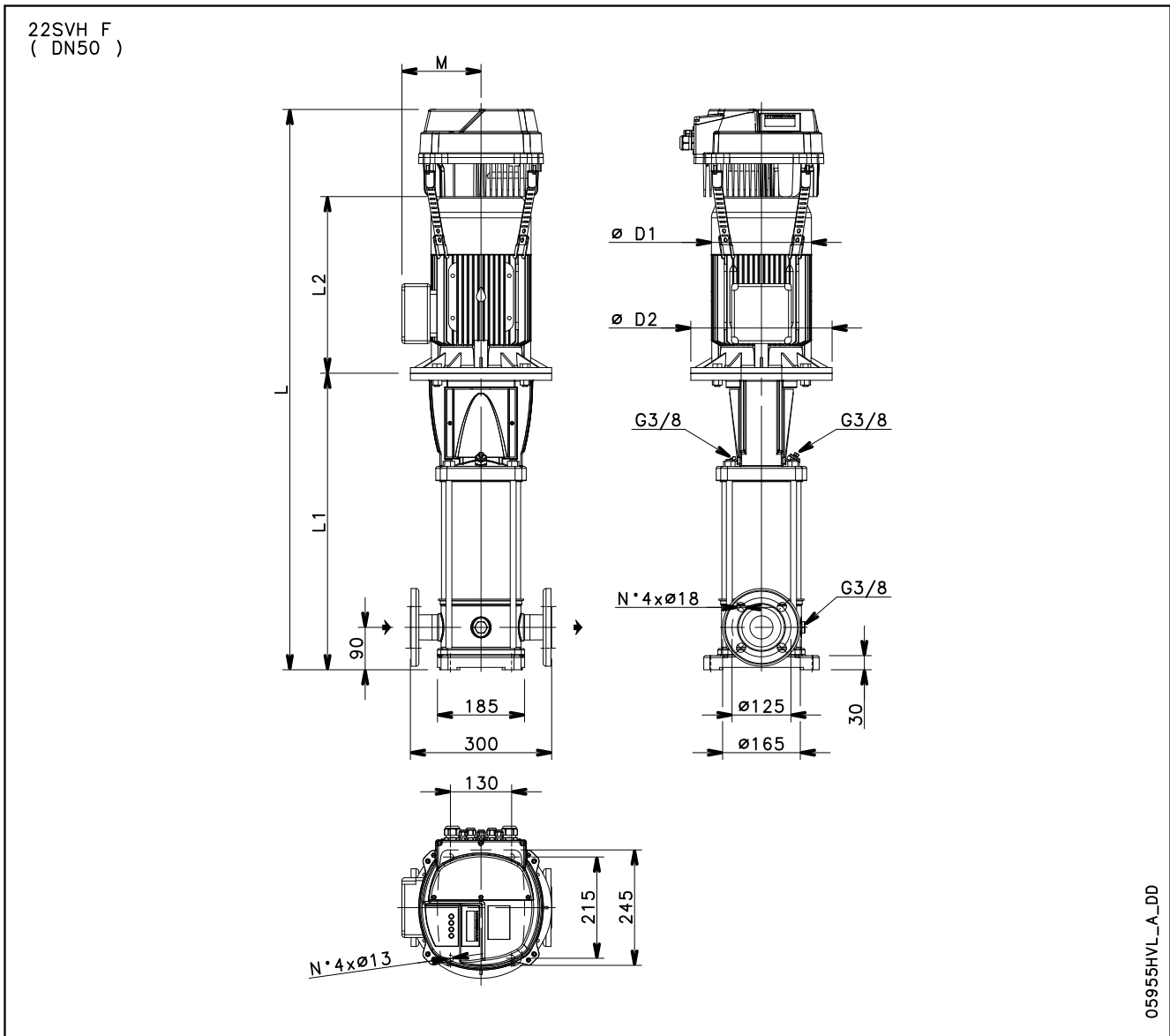

PUMP TYPE	MOTOR		DIMENSIONS (mm)					L			WEIGHT (kg)		
			L1	L2	M	D1	D2	/2	/3	/4	/2	/3	/4
				3 ~	3 ~	3 ~		1 ~ 230V	3 ~ 230V	3 ~ 400V	1 ~ 230V	3 ~ 230V	3 ~ 400V
22SVH01	1,1	80	399	263	129	155	120	832	832	832	32,5	32,5	32,5
22SVH03	3	100	467	298	134	174	160	950	950	935	50,9	50,9	46,0
22SVH04	4	112	515	319	154	197	160	1019	1019	1004	57,6	57,6	52,7
22SVH05	5,5	132	630	375	168	214	300	-	1190	1190	-	75,5	75,5
22SVH07	7,5	132	726	367	191	256	300	-	1293	1278	-	101,6	96,5
22SVH10	11	160	900	428	191	256	350	-	1528	1513	-	122,6	117,5
22SVH14	15	160	1092	494	240	313	350	-	-	1786	-	-	159,6
22SVH17	18,5	160	1236	494	240	313	350	-	-	1930	-	-	171,6

22svh-HVL-2p50-en_a_td

33SVH SERIES DIMENSIONS AND WEIGHTS AT 50 Hz, 2 POLES

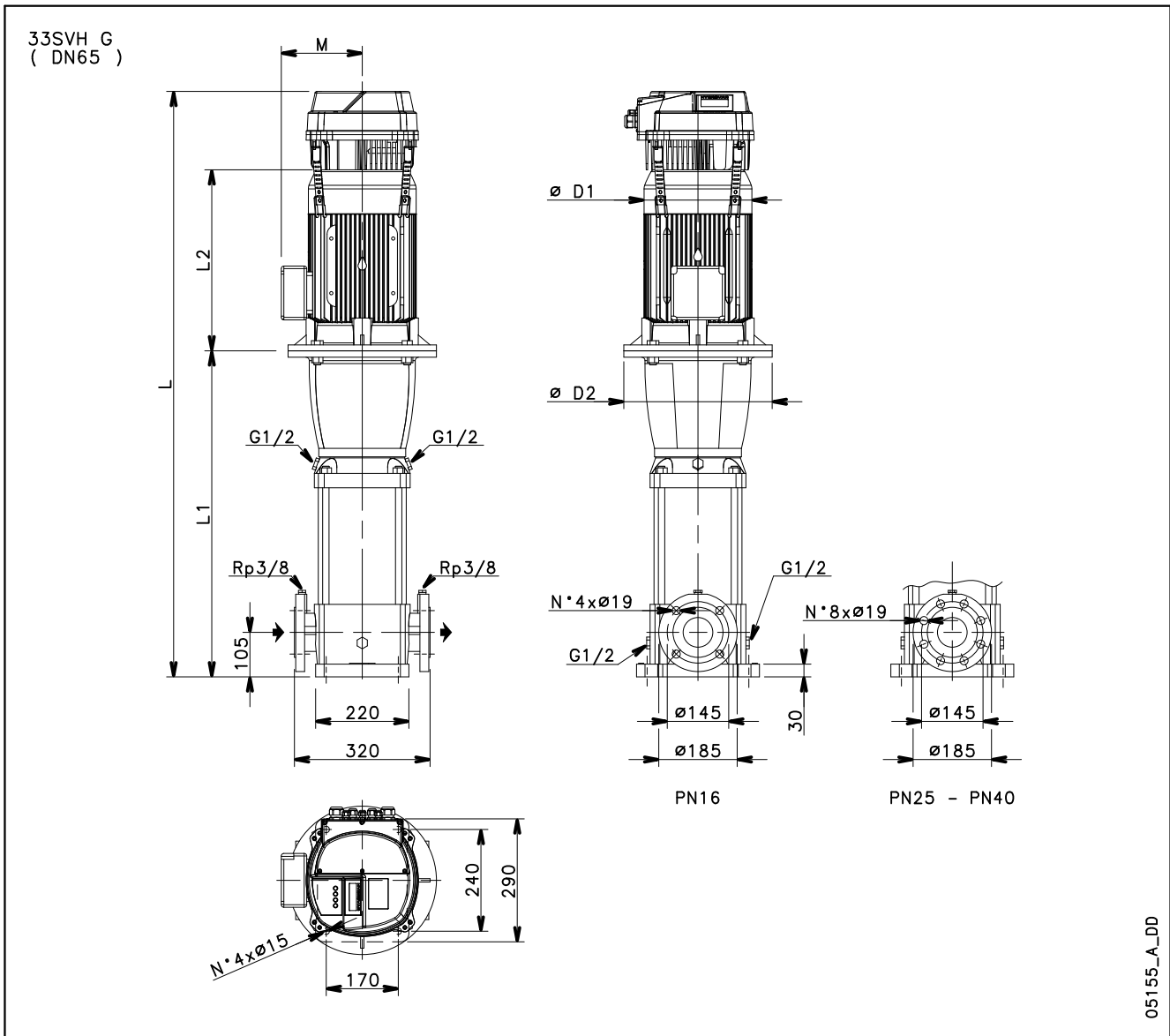

PUMP TYPE	MOTOR		DIMENSIONS (mm)						L			WEIGHT (kg)				
			kW	SIZE	L1	L2	D1	D2	M	PN	/2	/3	/4	/2	/3	/4
											1~ 230V	3~ 230V	3~ 400V	1~ 230V	3~ 230V	3~ 400V
33SVH1	3	100	489	298	174	164	134	16	972	972	957	83,5	83,5	78,6		
33SVH2	5,5	132	584	375	214	300	168	16	-	1144	1144	-	109,0	109,0		
33SVH3	7,5	132	659	367	256	300	191	16	-	1226	1211	-	136,6	131,5		
33SVH4	11	160	769	428	256	350	191	16	-	1397	1382	-	158,6	153,5		
33SVH5	15	160	844	494	313	350	240	16	-	-	1538	-	-	194,6		
33SVH6	15	160	919	494	313	350	240	25	-	-	1613	-	-	198,6		
33SVH7	18,5	160	994	494	313	350	240	25	-	-	1688	-	-	210,6		

33svh-HVL-2p50-en_a_td

46SVH SERIES DIMENSIONS AND WEIGHTS AT 50 Hz, 2 POLES

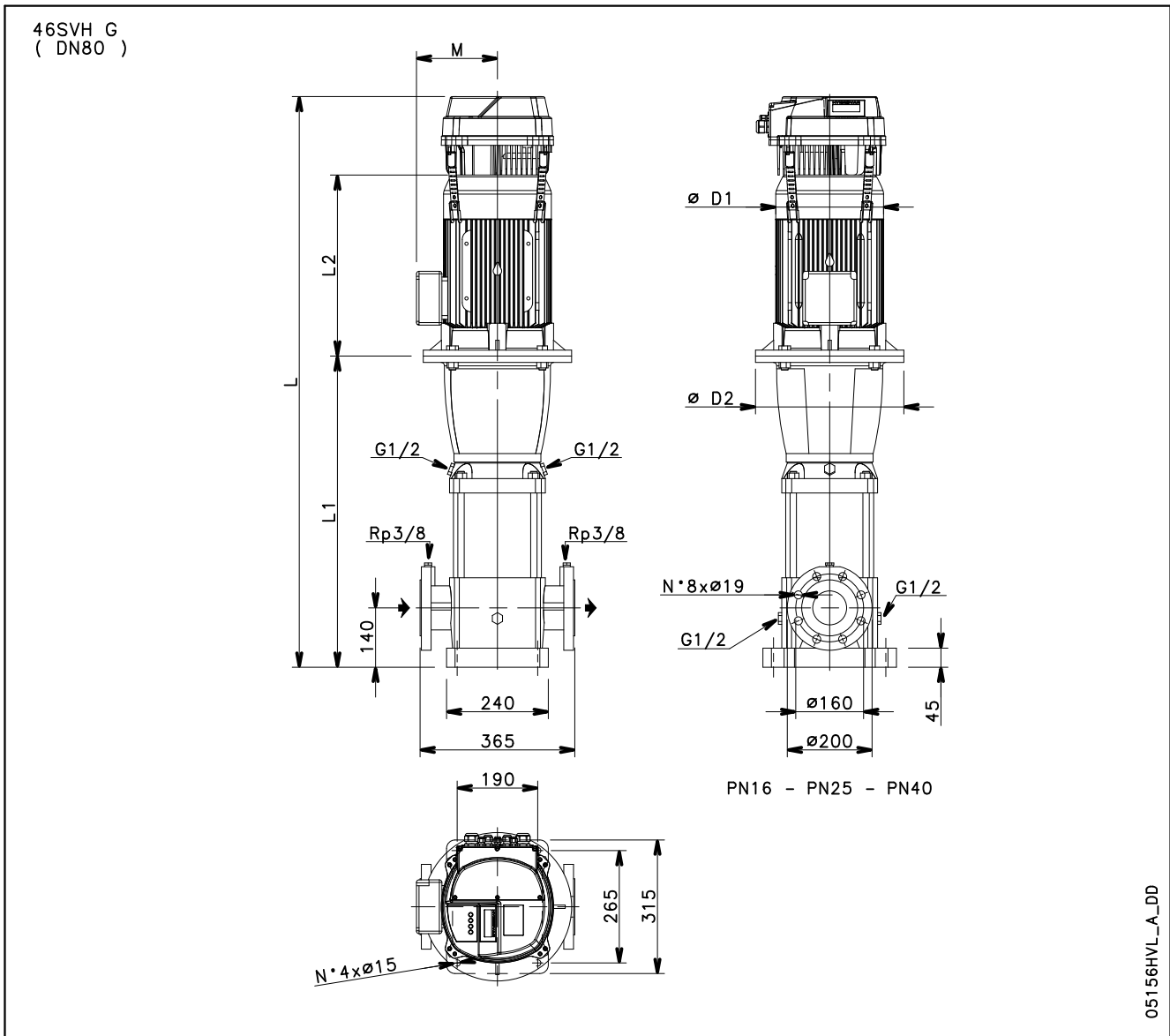

05156HVL_A_DD

PUMP TYPE	MOTOR		DIMENSIONS (mm)						WEIGHT (kg)							
			kW	SIZE	L1	L2	D1	D2	M	PN	L			WEIGHT (kg)		
											/2	/3	/4	/2	/3	/4
46SVH1	4	112	529	319	197	164	154	16	1033	1033	1018	95,0	95,0	90,1		
46SVH2	7,5	132	624	367	256	300	191	16	-	1191	1176	-	137,6	132,5		
46SVH3	11	160	734	428	256	350	191	16	-	1362	1347	-	159,6	154,5		
46SVH4	15	160	809	494	313	350	240	16	-	-	1503	-	-	195,6		
46SVH6	22	180	959	494	313	350	240	25	-	-	1653	-	-	223,6		

46svh-HVL-2p50-en_a_td

66SVH SERIES
DIMENSIONS AND WEIGHTS AT 50 Hz, 2 POLES

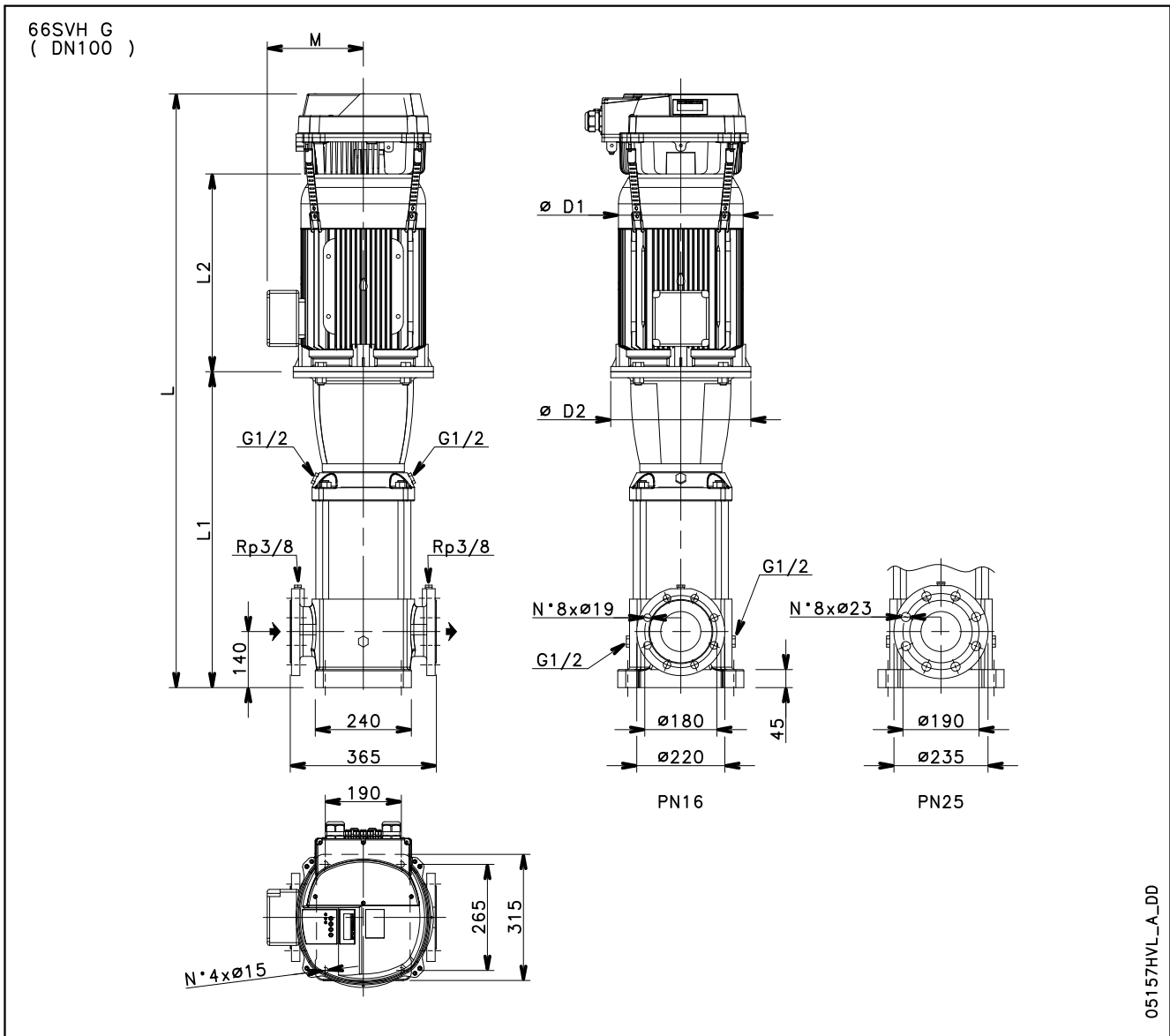

05157HVL_A_DD

PUMP TYPE	MOTOR		DIMENSIONS (mm)						WEIGHT (kg)					
									L					
									/2	/3	/4	/2	/3	/4
	kW	SIZE	L1	L2	D1	D2	M	PN	1~ 230V	3~ 230V	3~ 400V	1~ 230V	3~ 230V	3~ 400V
66SVH1	5,5	132	574	375	214	300	168	16	-	1134	1134	-	120,5	120,5
66SVH2	11	160	699	428	256	350	191	16	-	1327	1312	-	166,6	161,5
66SVH3	18,5	160	789	494	313	350	240	16	-	-	1483	-	-	212,6
66SVH4	22	180	879	494	313	350	240	16	-	-	1573	-	-	229,6

66svh-HVL-2p50-en_a_td

92SVH SERIES
DIMENSIONS AND WEIGHTS AT 50 Hz, 2 POLES

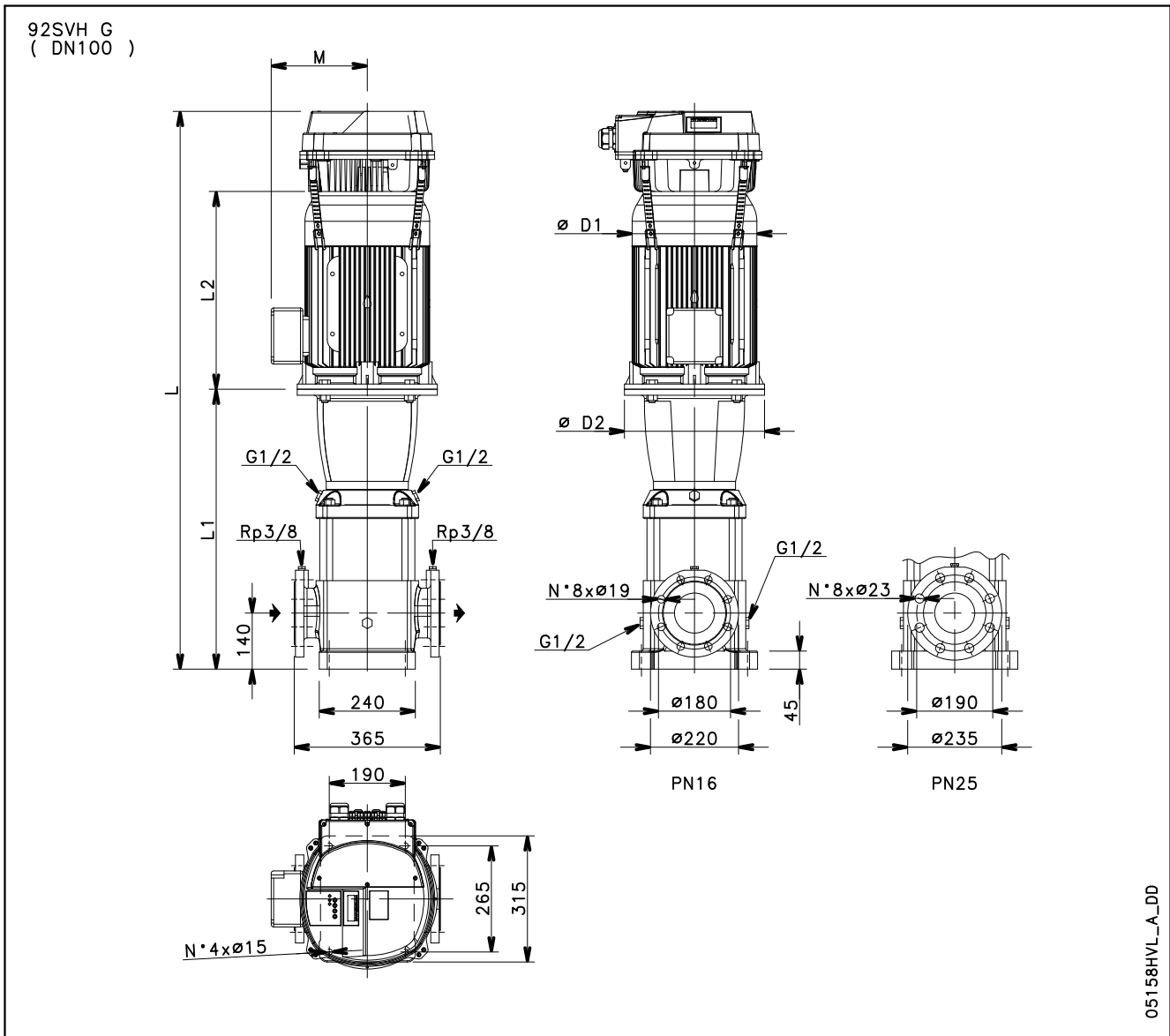

05158HVL_A_DD

PUMP TYPE	MOTOR		DIMENSIONS (mm)						WEIGHT (kg)					
									L			WEIGHT (kg)		
									/2	/3	/4	/2	/3	/4
	kW	SIZE	L1	L2	D1	D2	M	PN	1~ 230V	3~ 230V	3~ 400V	1~ 230V	3~ 230V	3~ 400V
92SVH1	7,5	132	574	367	256	300	191	16	-	1141	1126	-	142,6	137,5
92SVH2	15	160	699	494	313	350	240	16	-	-	1393	-	-	197,6
92SVH3	22	180	789	494	313	350	240	16	-	-	1483	-	-	223,6

1SVH SERIES

OPERATING CHARACTERISTICS AT 30..50 Hz

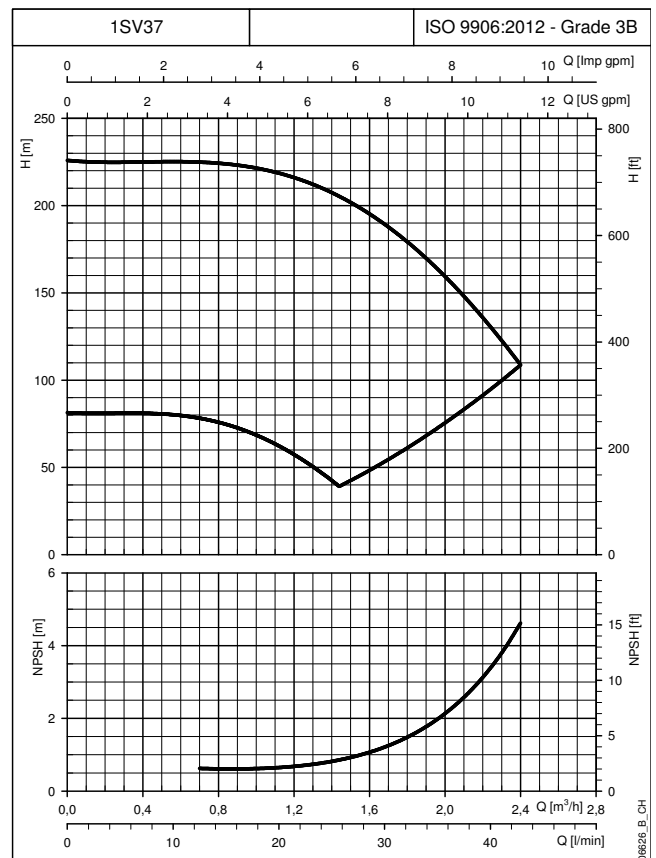
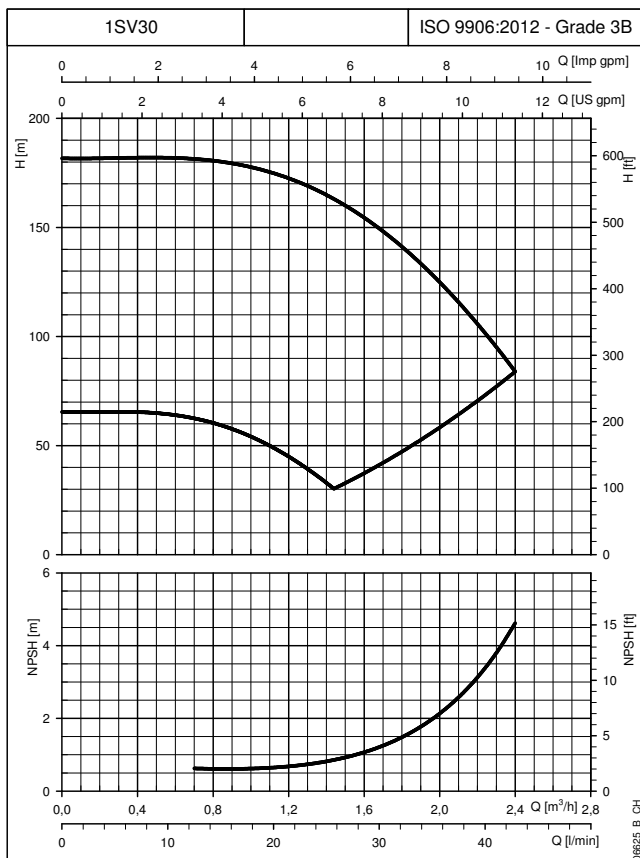
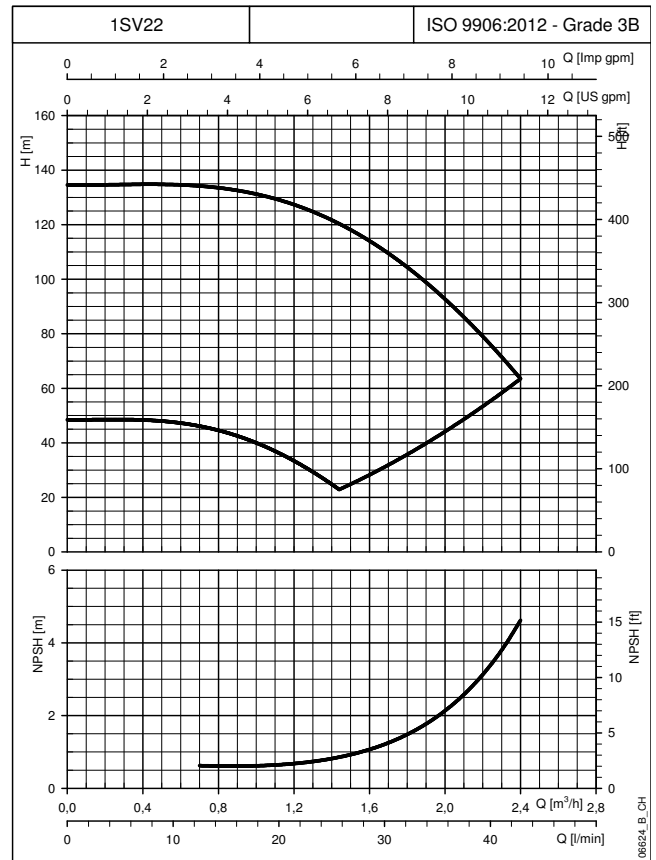
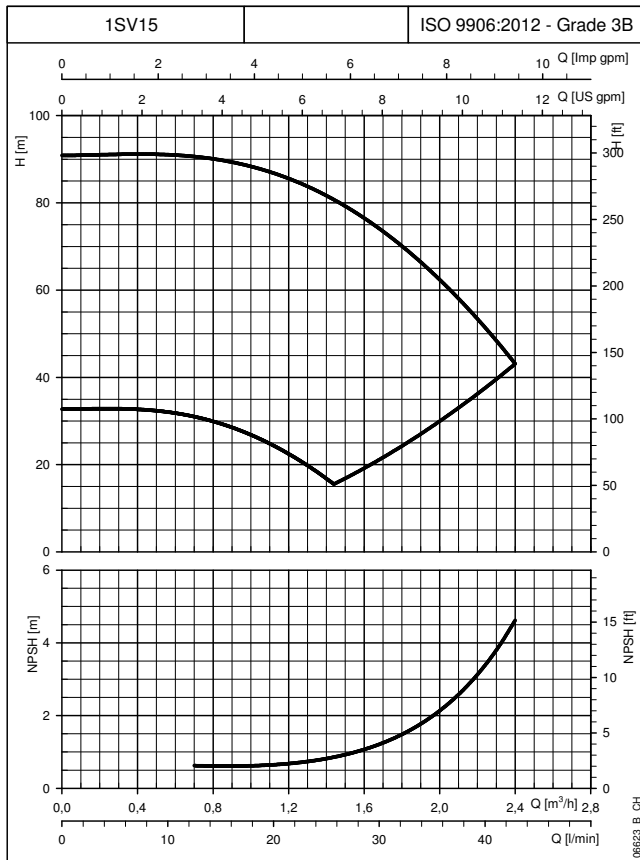

The curves show the performance with one pump running to the minimum and maximum speed. These performances are valid for liquids with density $\rho = 1.0 \text{ Kg/dm}^3$ and kinematic viscosity $\nu = 1 \text{ mm}^2/\text{s}$.

3SVH SERIES OPERATING CHARACTERISTICS AT 30..50 Hz

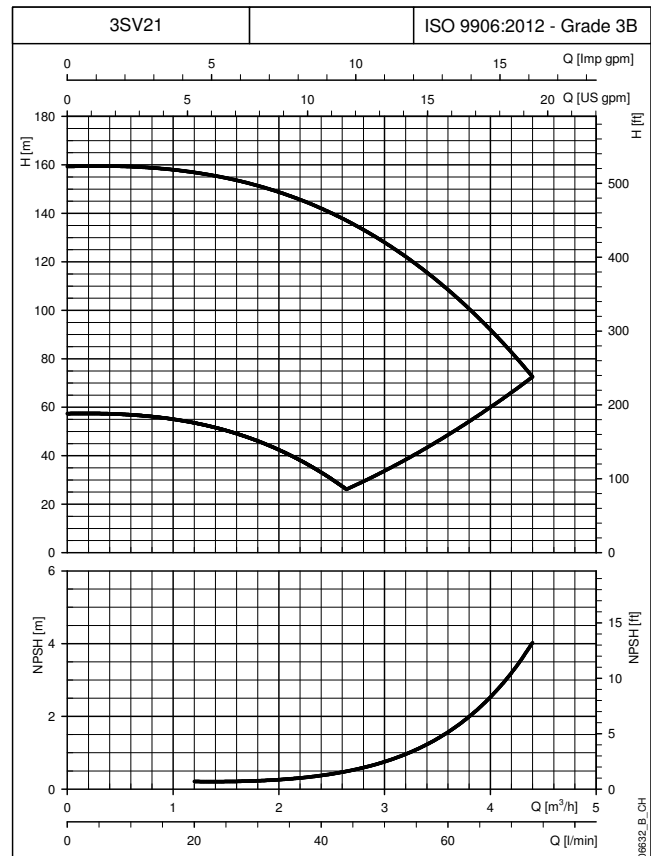
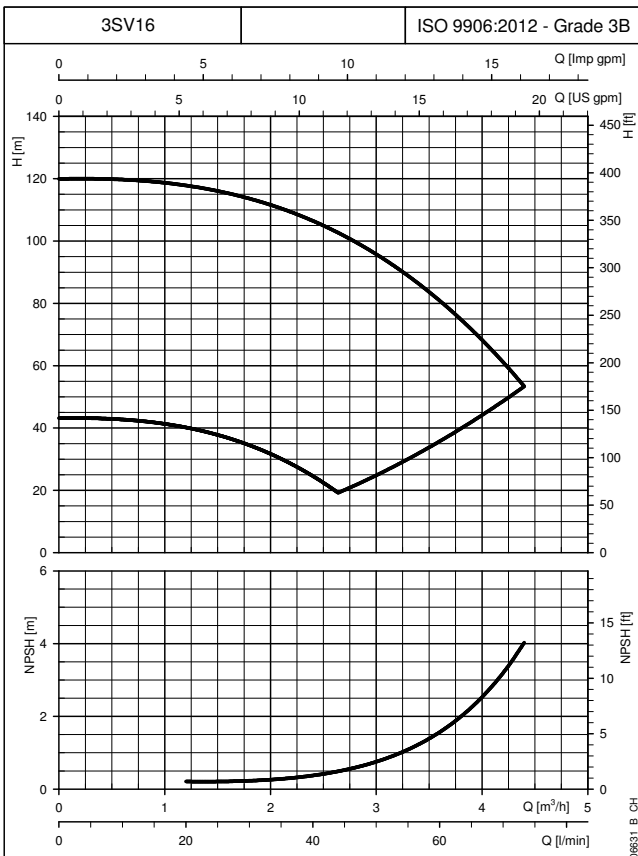
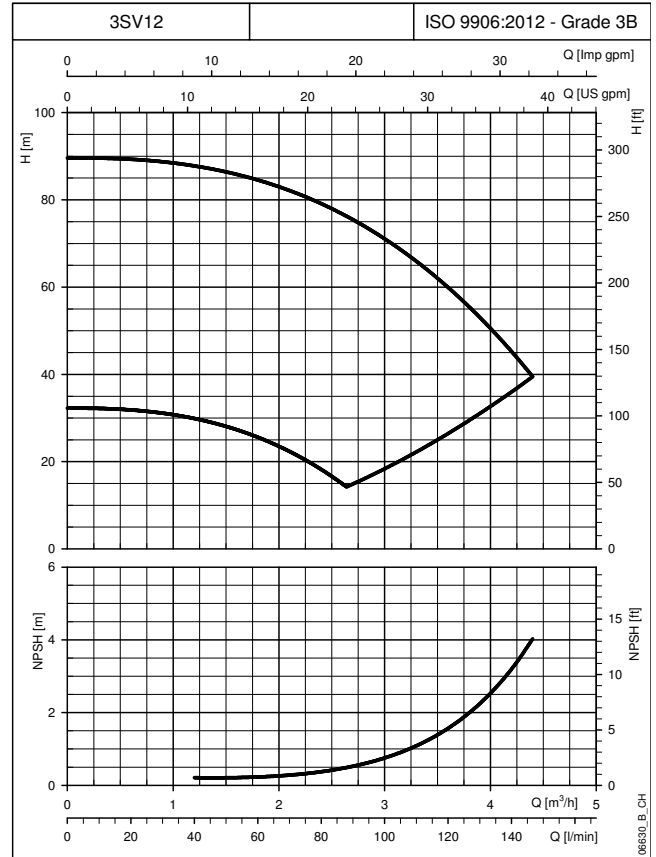
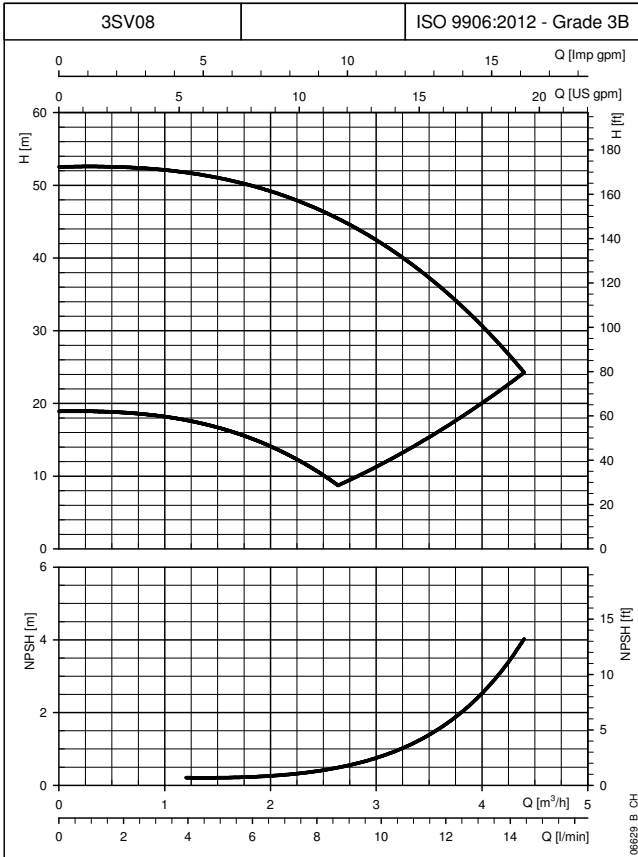

The curves show the performance with one pump running to the minimum and maximum speed. These performances are valid for liquids with density $\rho = 1.0 \text{ Kg/dm}^3$ and kinematic viscosity $\nu = 1 \text{ mm}^2/\text{s}$.

3SVH SERIES OPERATING CHARACTERISTICS AT 30..50 Hz

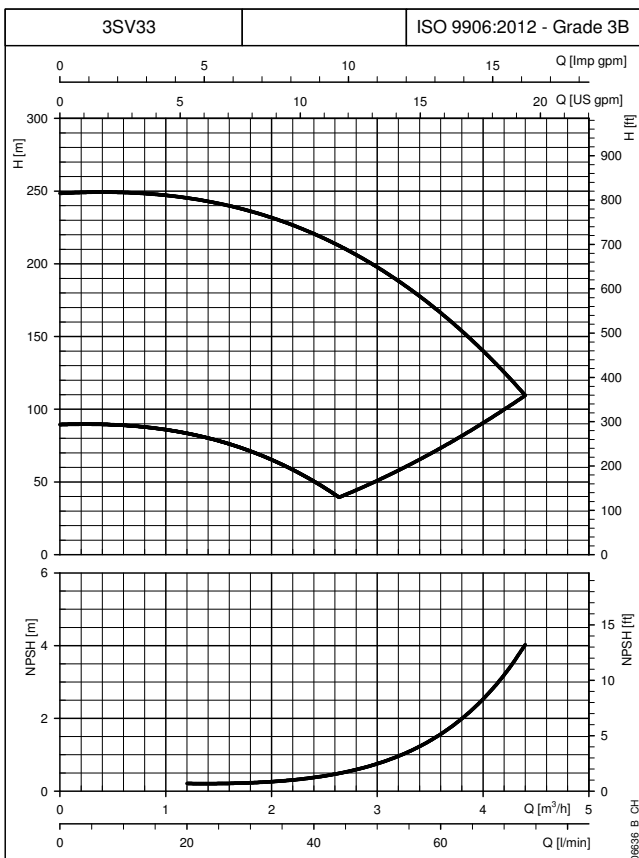
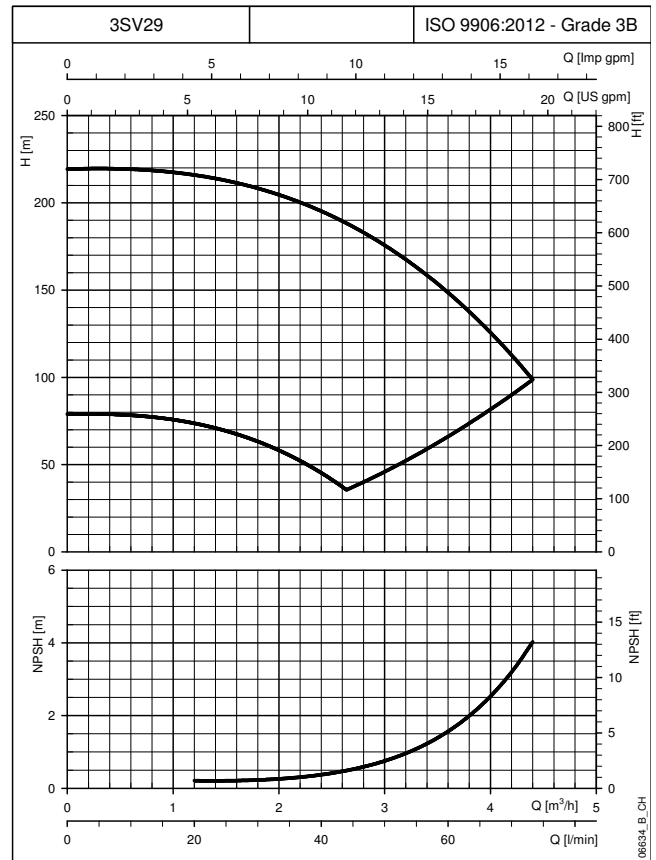
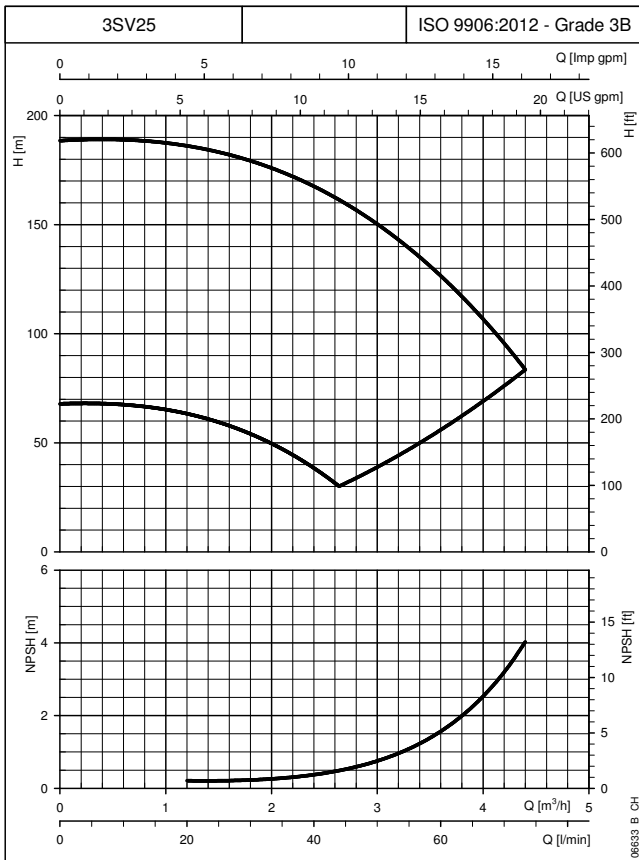

The curves show the performance with one pump running to the minimum and maximum speed. These performances are valid for liquids with density $\rho = 1.0 \text{ Kg/dm}^3$ and kinematic viscosity $\nu = 1 \text{ mm}^2/\text{s}$.

5SVH SERIES OPERATING CHARACTERISTICS AT 30..50 Hz

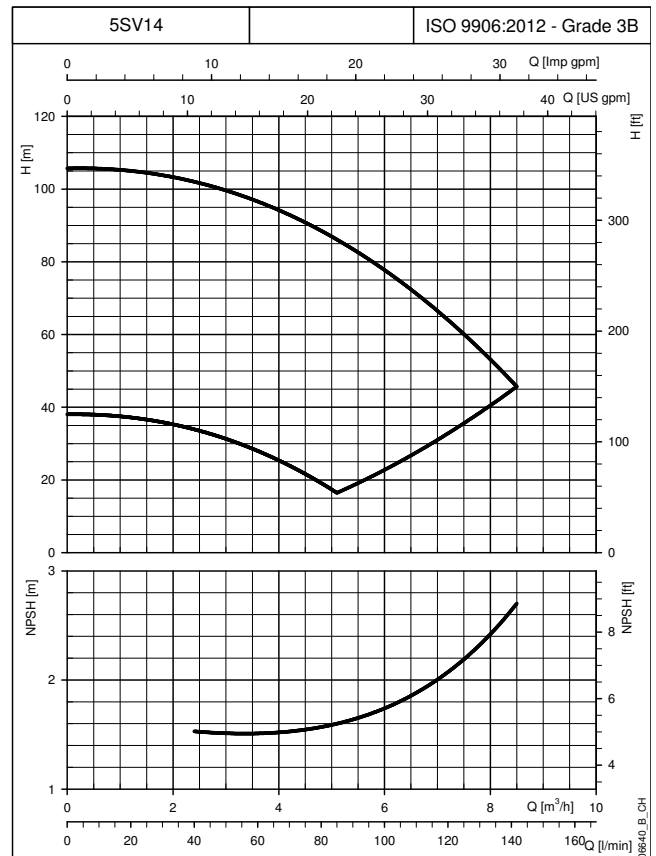
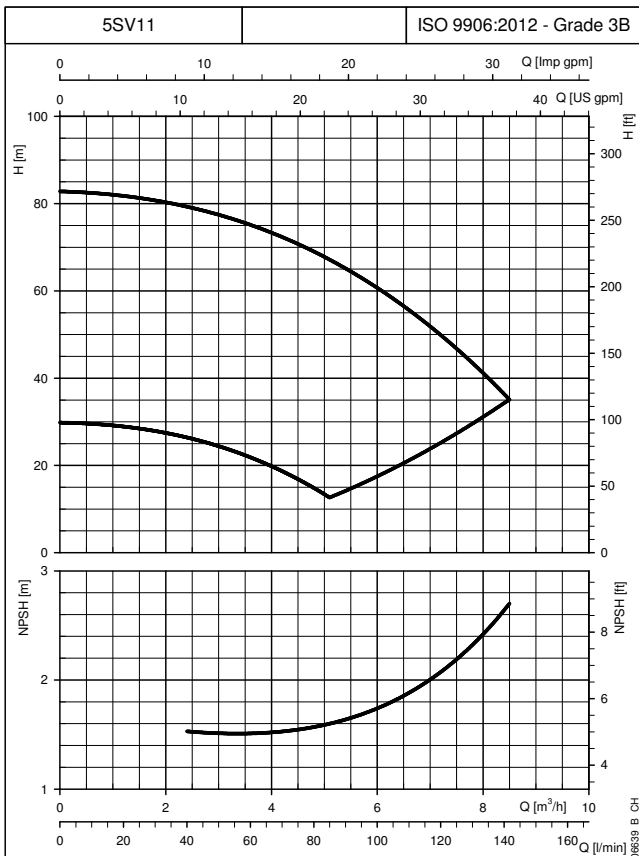
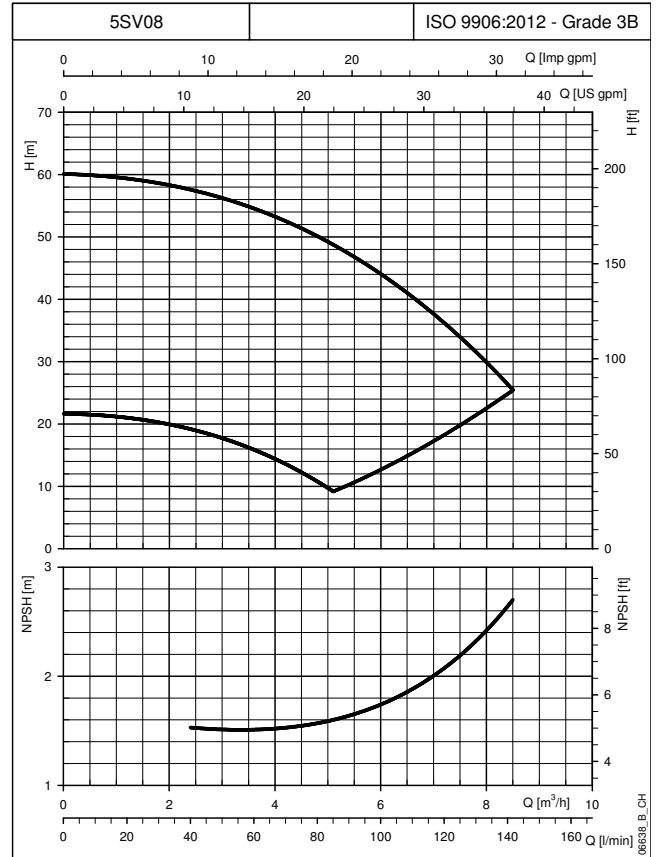
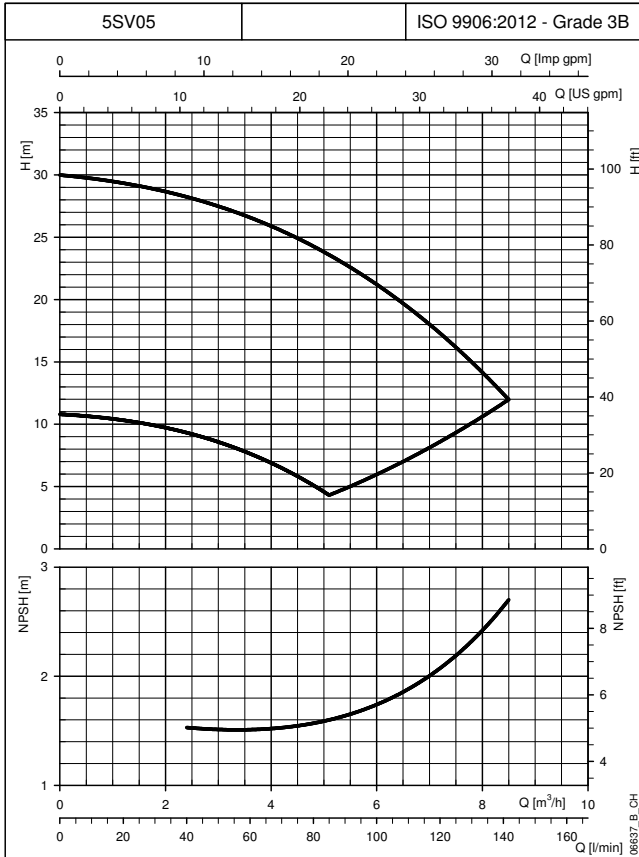

The curves show the performance with one pump running to the minimum and maximum speed. These performances are valid for liquids with density $\rho = 1.0 \text{ Kg/dm}^3$ and kinematic viscosity $\nu = 1 \text{ mm}^2/\text{s}$.

5SVH SERIES OPERATING CHARACTERISTICS AT 30..50 Hz

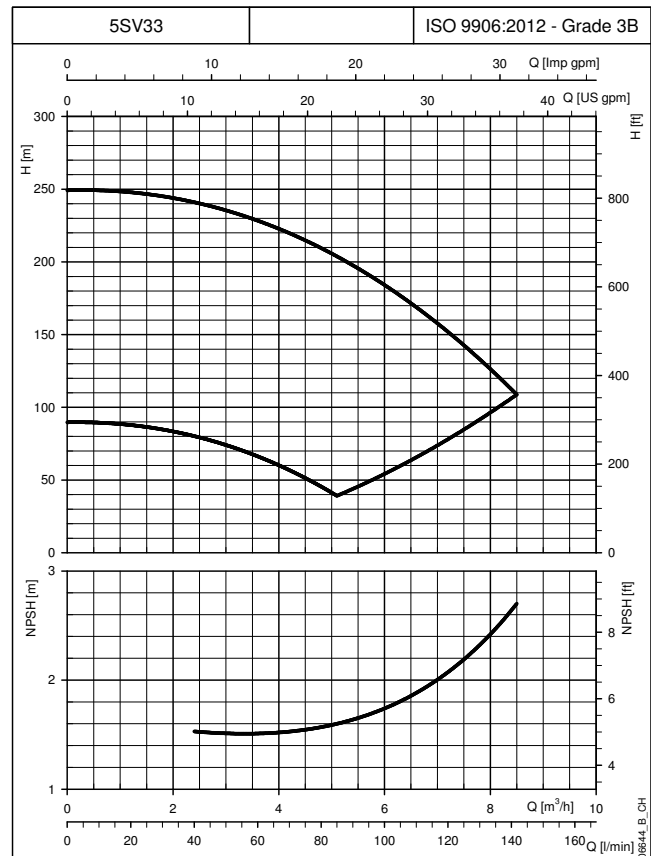
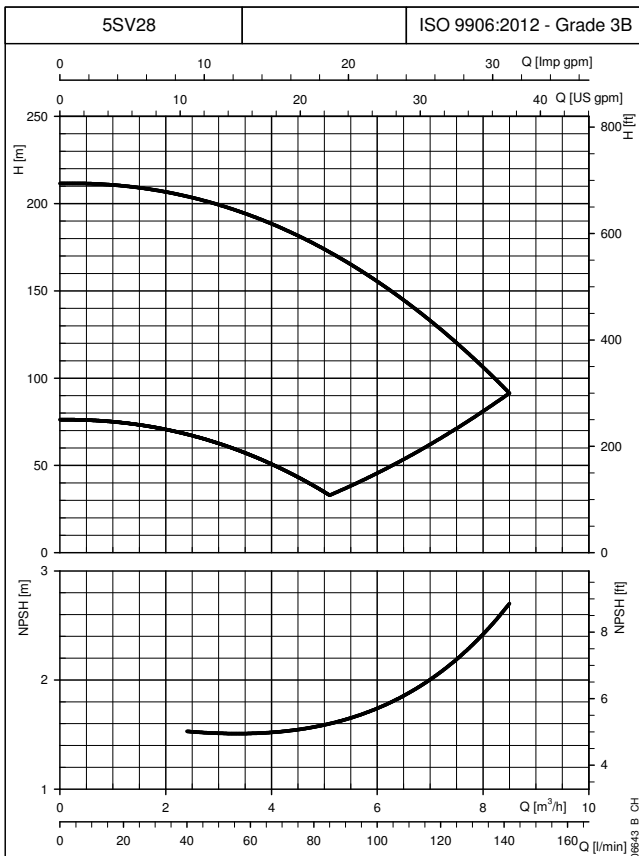
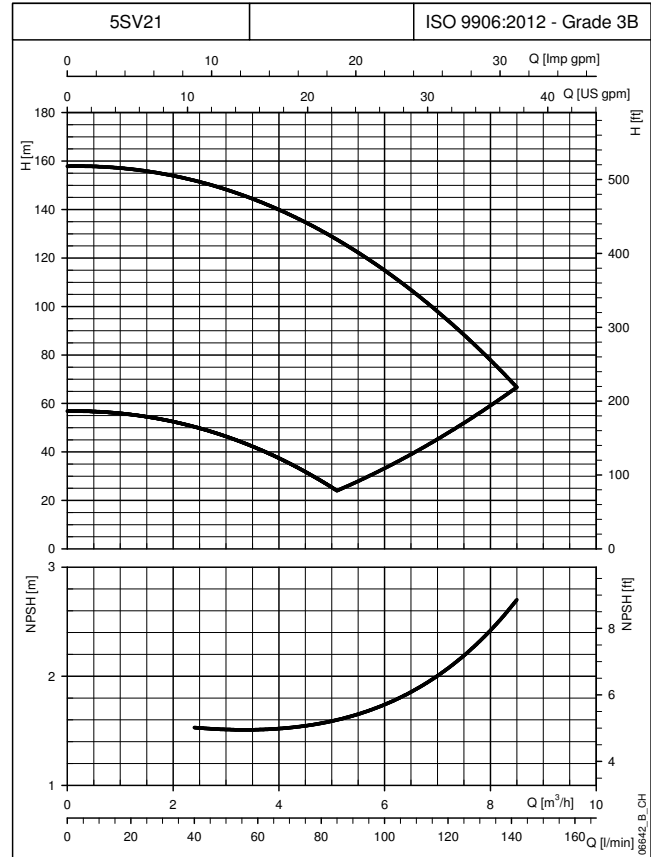
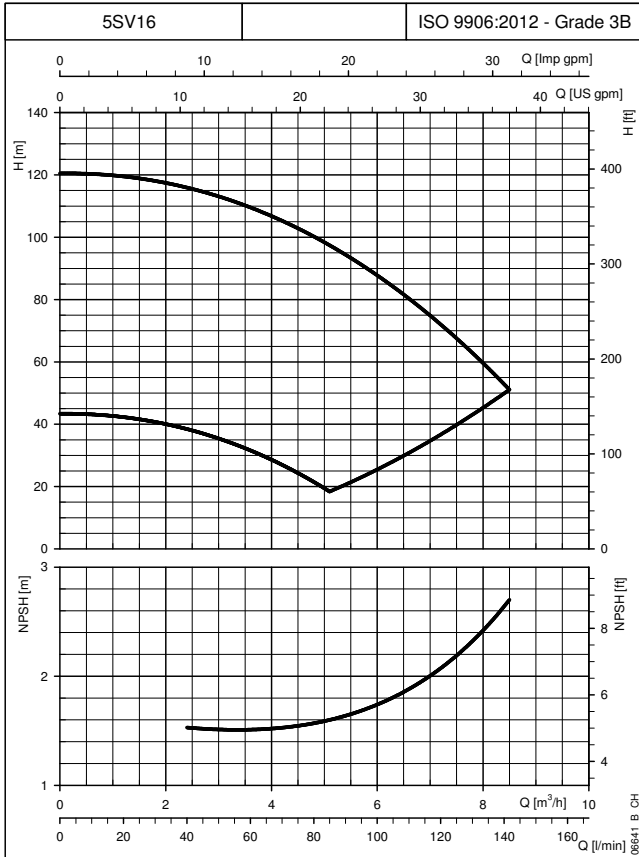

The curves show the performance with one pump running to the minimum and maximum speed. These performances are valid for liquids with density $\rho = 1.0 \text{ Kg/dm}^3$ and kinematic viscosity $\nu = 1 \text{ mm}^2/\text{s}$.

10SVH SERIES

OPERATING CHARACTERISTICS AT 30..50 Hz

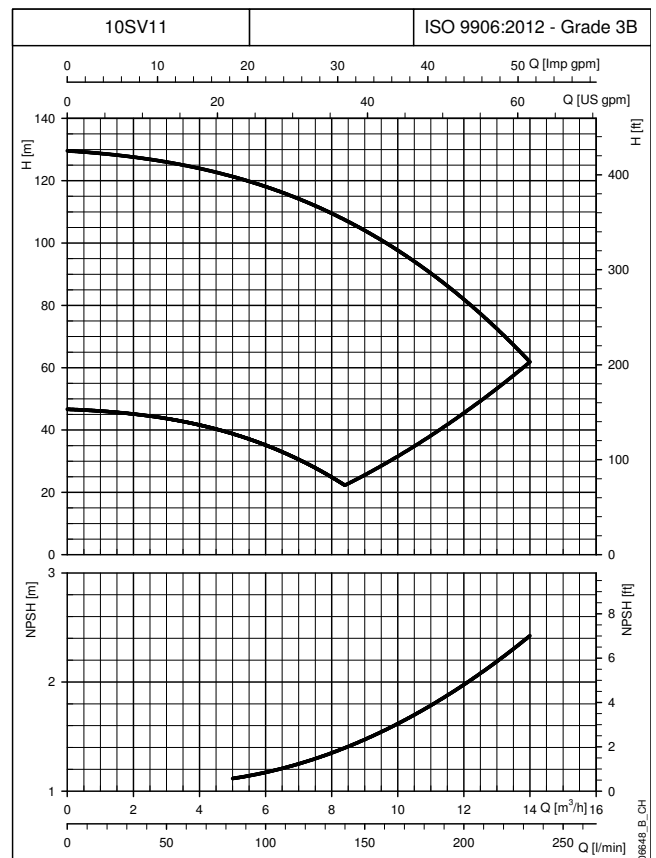
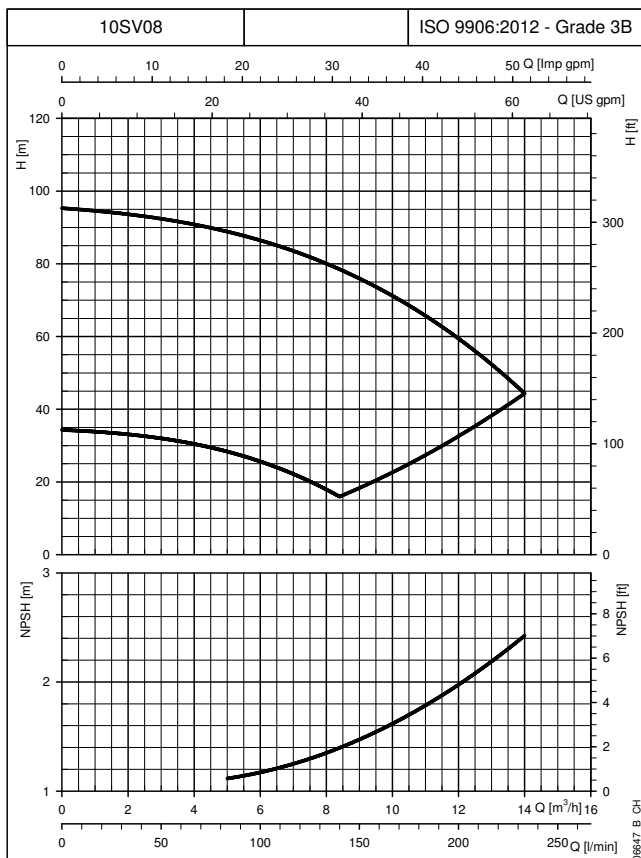
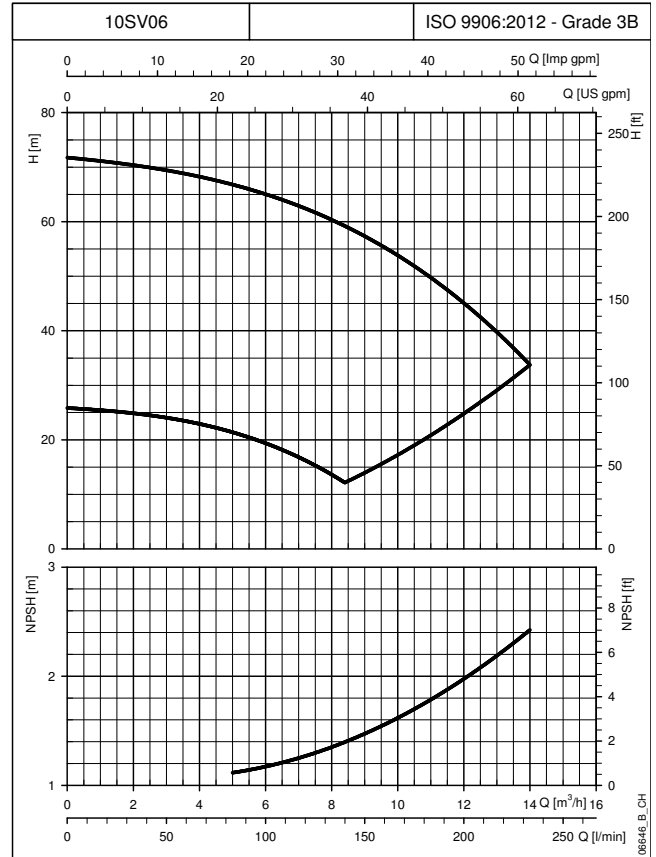
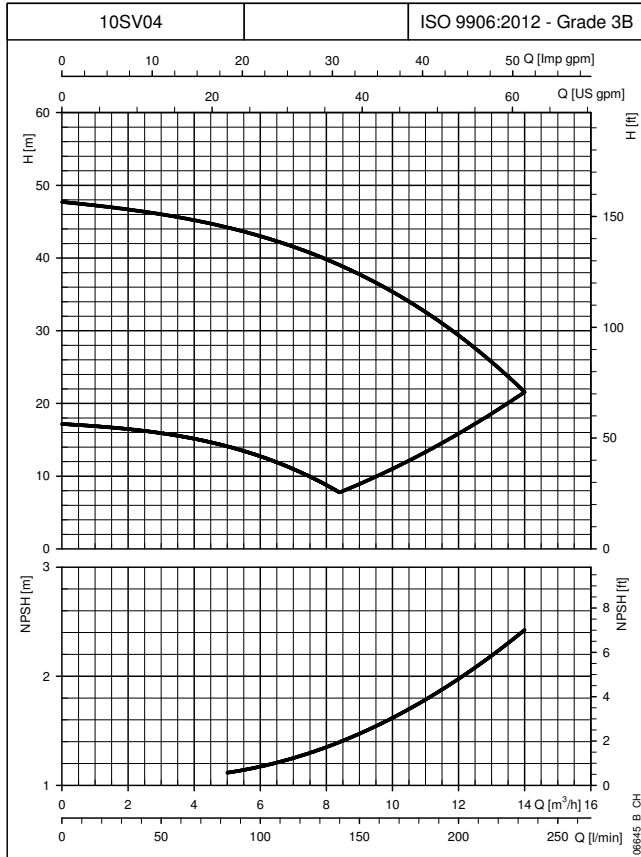

The curves show the performance with one pump running to the minimum and maximum speed. These performances are valid for liquids with density $\rho = 1.0 \text{ Kg/dm}^3$ and kinematic viscosity $\nu = 1 \text{ mm}^2/\text{s}$.

**10SVH SERIES
OPERATING CHARACTERISTICS AT 30..50 Hz**

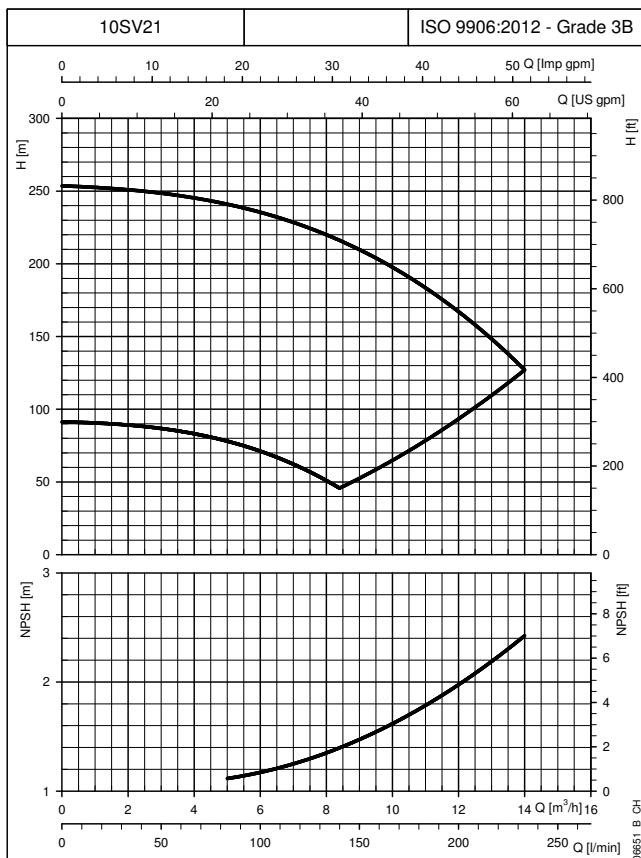
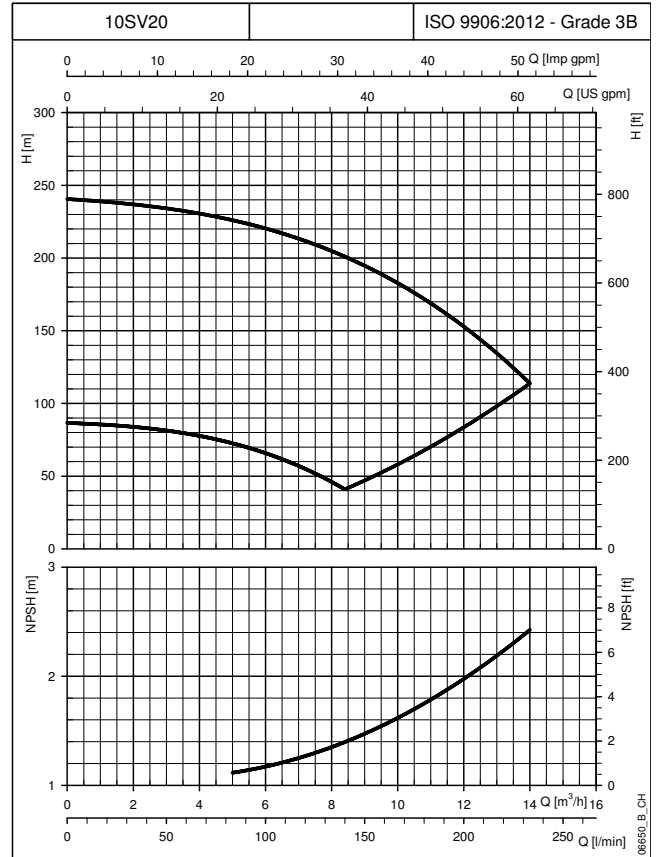
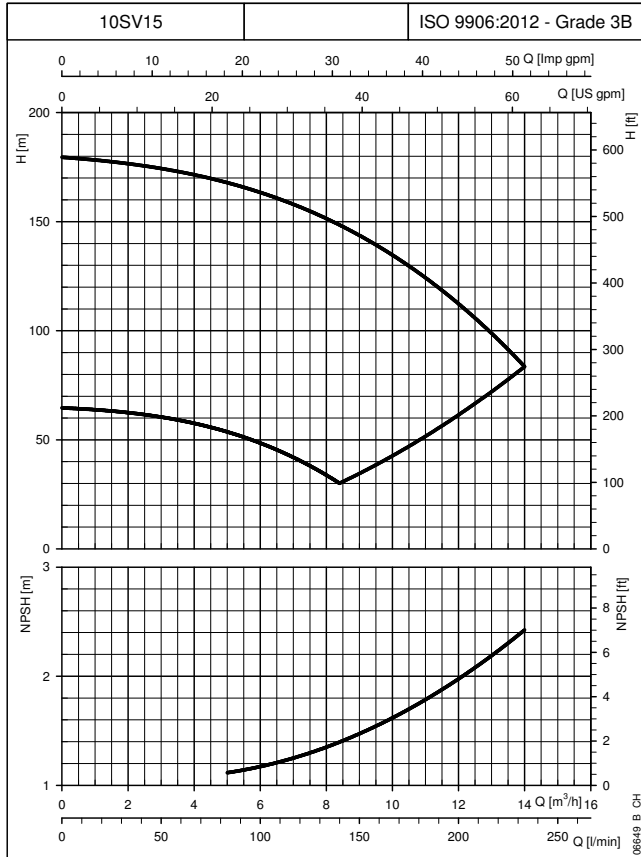

The curves show the performance with one pump running to the minimum and maximum speed. These performances are valid for liquids with density $\rho = 1.0 \text{ Kg/dm}^3$ and kinematic viscosity $\nu = 1 \text{ mm}^2/\text{s}$.

15SVH SERIES

OPERATING CHARACTERISTICS AT 30..50 Hz

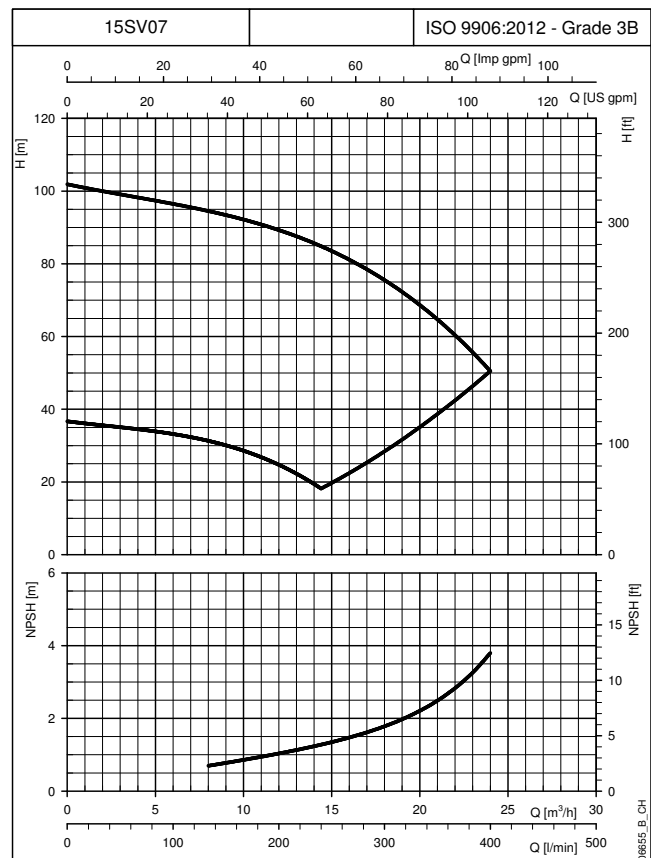
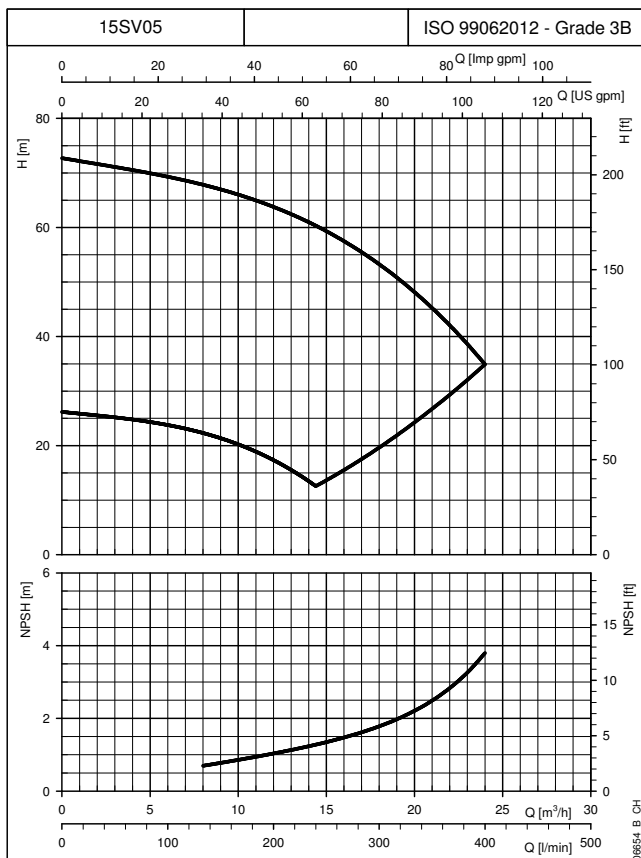
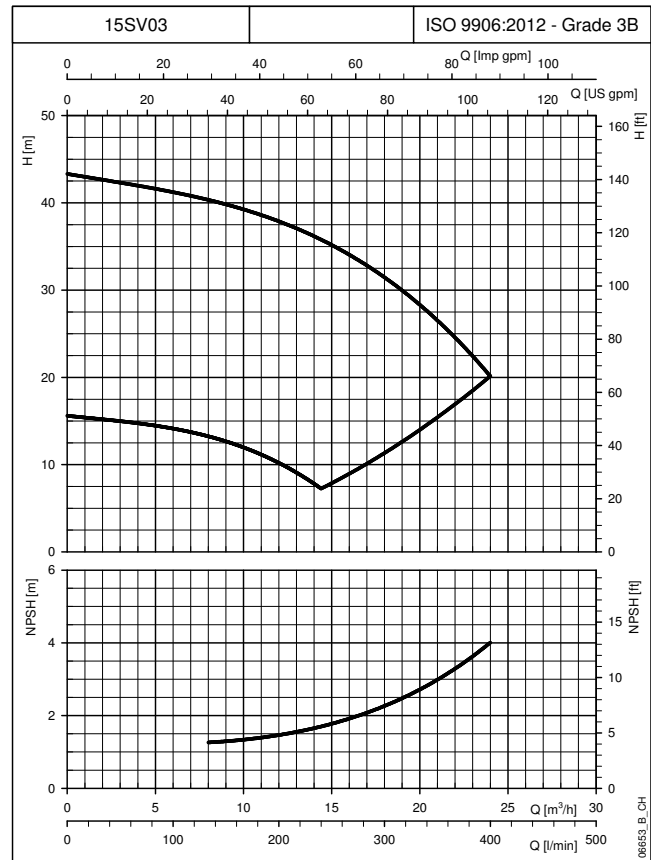
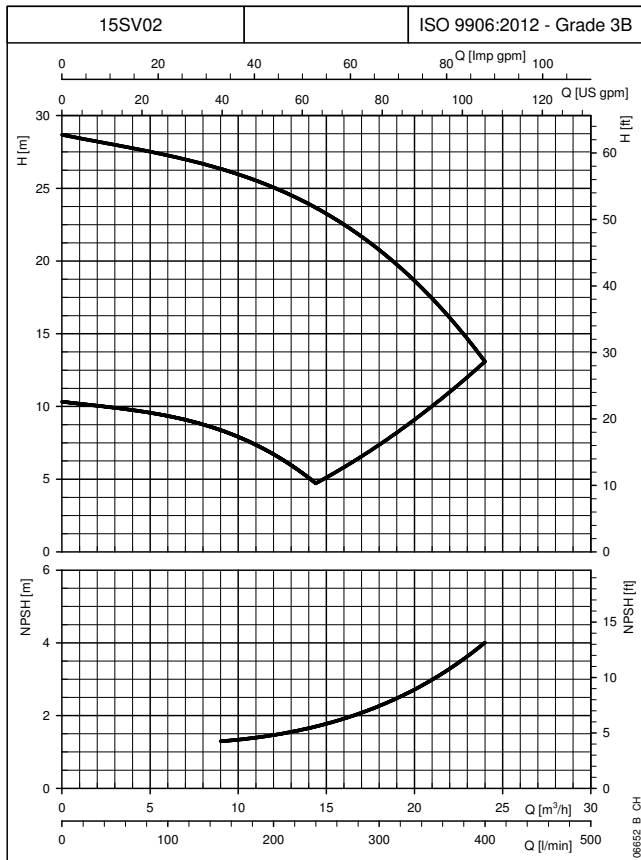

The curves show the performance with one pump running to the minimum and maximum speed.
 These performances are valid for liquids with density $\rho = 1.0 \text{ Kg/dm}^3$ and kinematic viscosity $\nu = 1 \text{ mm}^2/\text{s}$.

15SVH SERIES

OPERATING CHARACTERISTICS AT 30..50 Hz

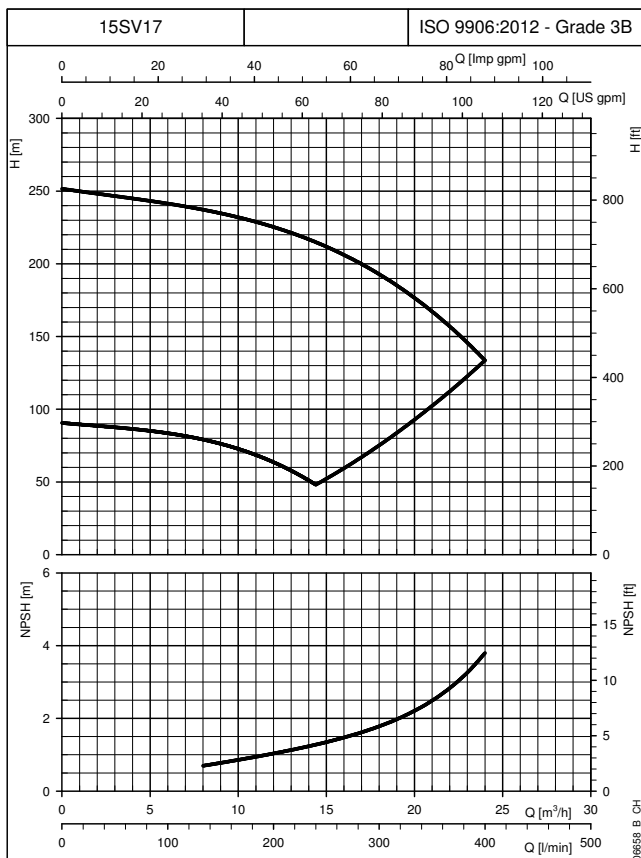
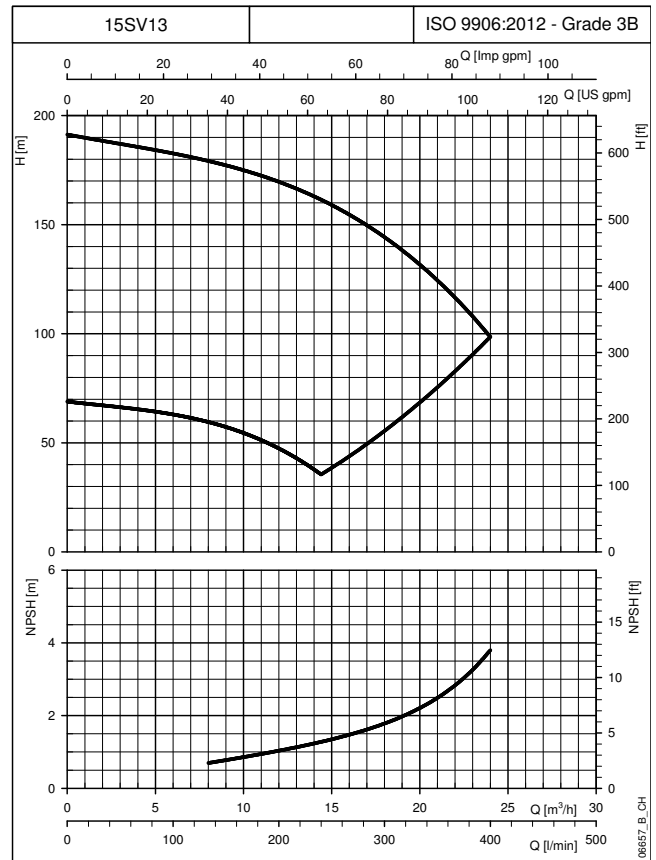
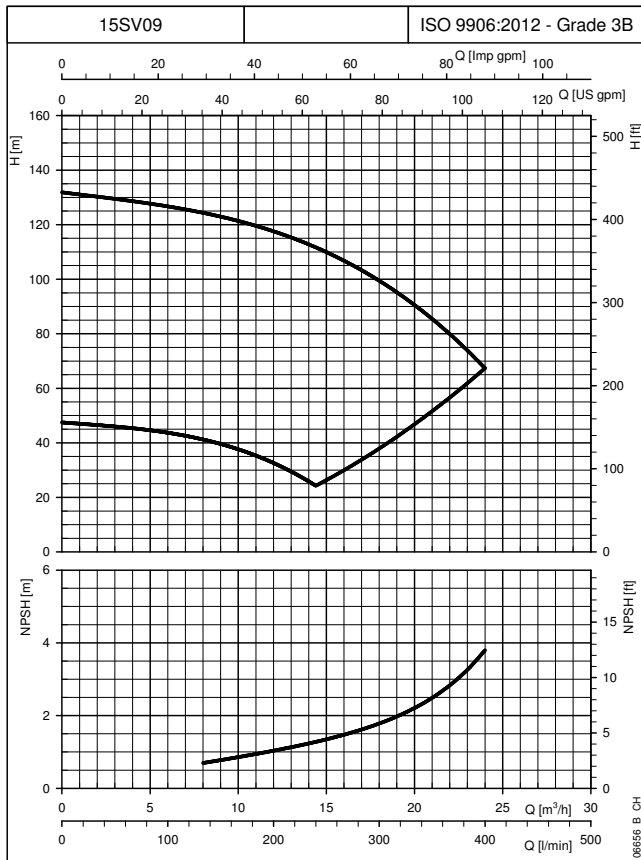

The curves show the performance with one pump running to the minimum and maximum speed. These performances are valid for liquids with density $\rho = 1.0 \text{ Kg/dm}^3$ and kinematic viscosity $\nu = 1 \text{ mm}^2/\text{s}$.

22SVH SERIES OPERATING CHARACTERISTICS AT 30..50 Hz

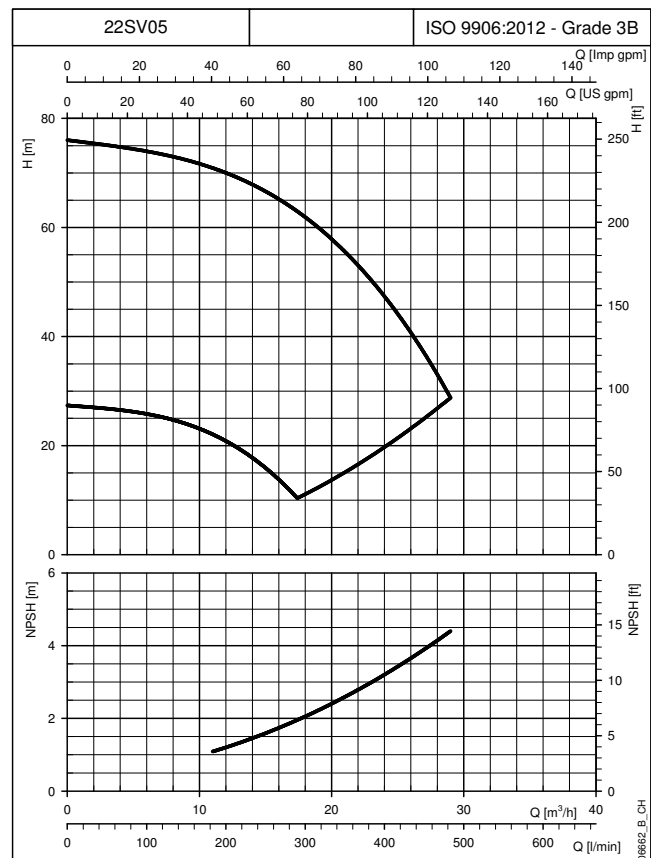
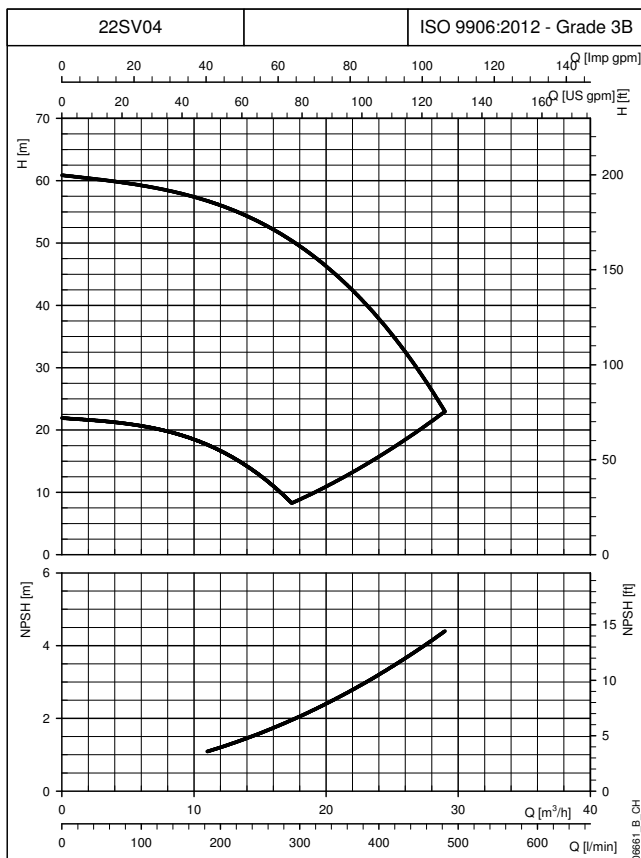
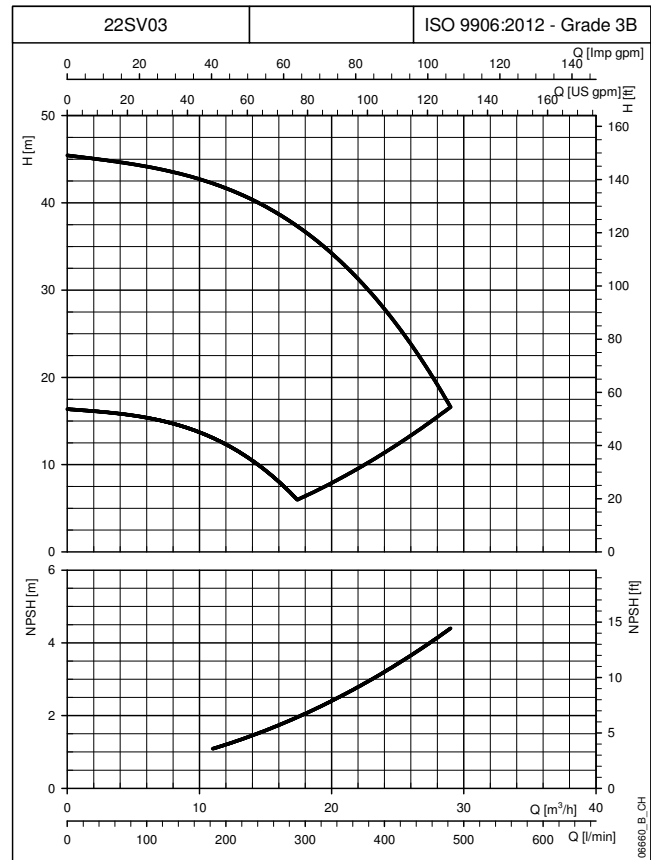
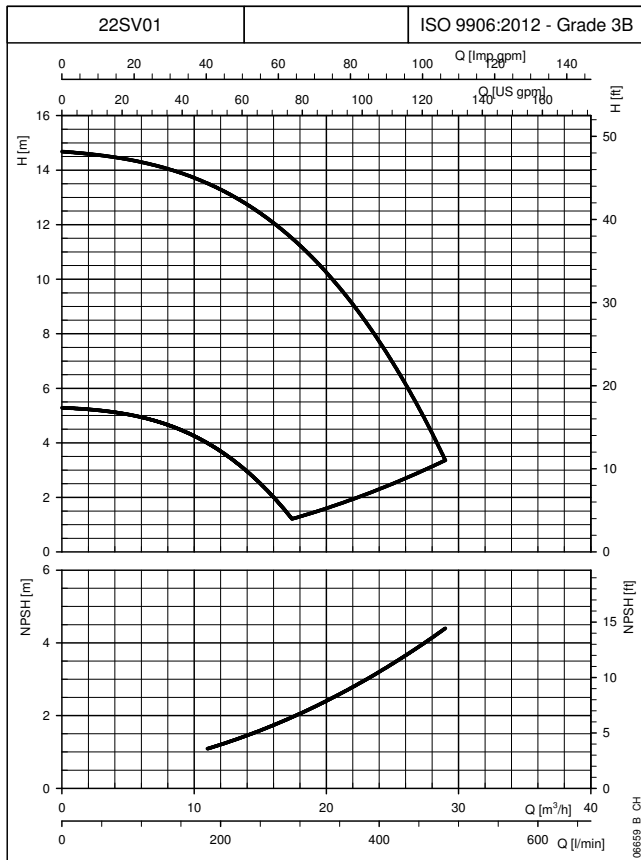

The curves show the performance with one pump running to the minimum and maximum speed.
These performances are valid for liquids with density $\rho = 1.0 \text{ Kg/dm}^3$ and kinematic viscosity $\nu = 1 \text{ mm}^2/\text{s}$.

22SVH SERIES OPERATING CHARACTERISTICS AT 30..50 Hz

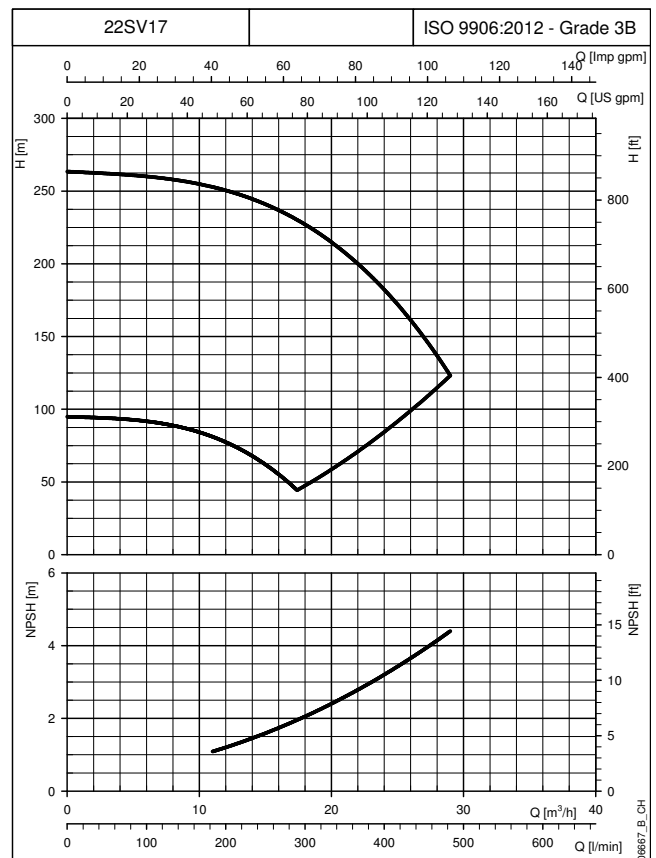
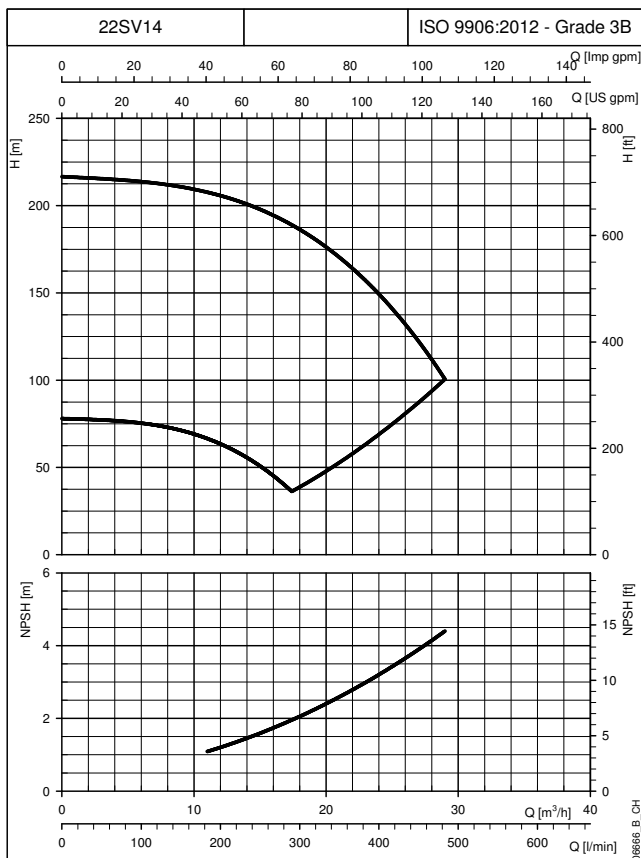
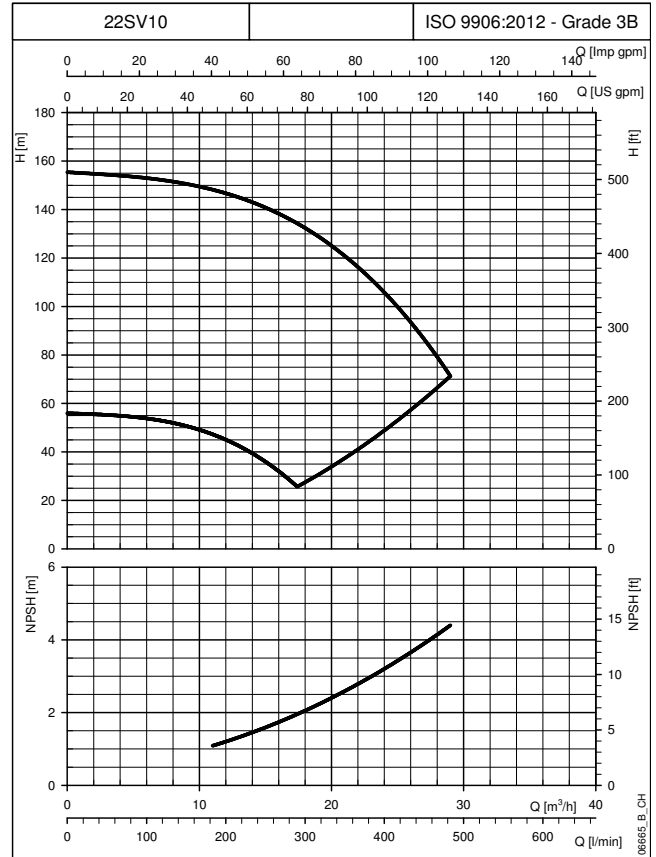
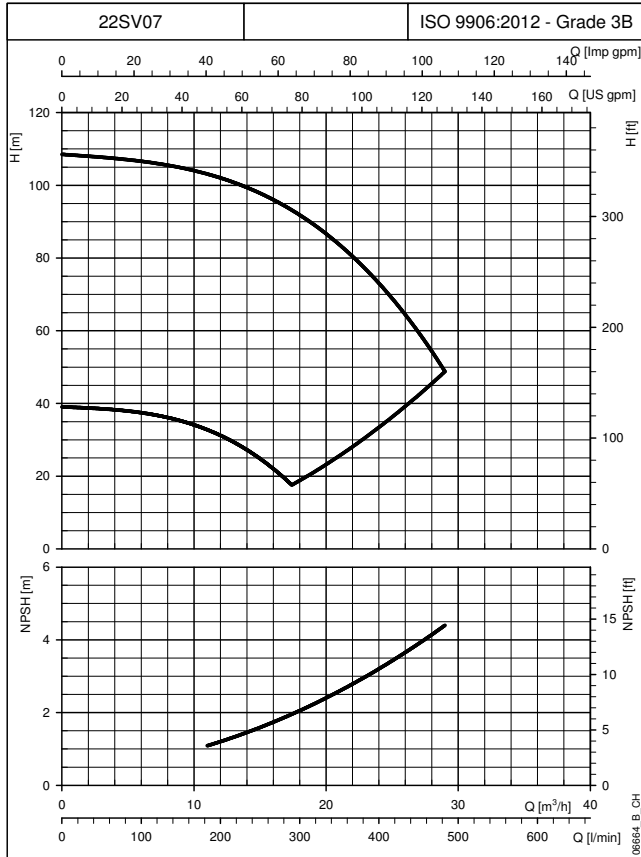

The curves show the performance with one pump running to the minimum and maximum speed. These performances are valid for liquids with density $\rho = 1.0 \text{ Kg/dm}^3$ and kinematic viscosity $\nu = 1 \text{ mm}^2/\text{s}$.

33SVH SERIES OPERATING CHARACTERISTICS AT 30..50 Hz

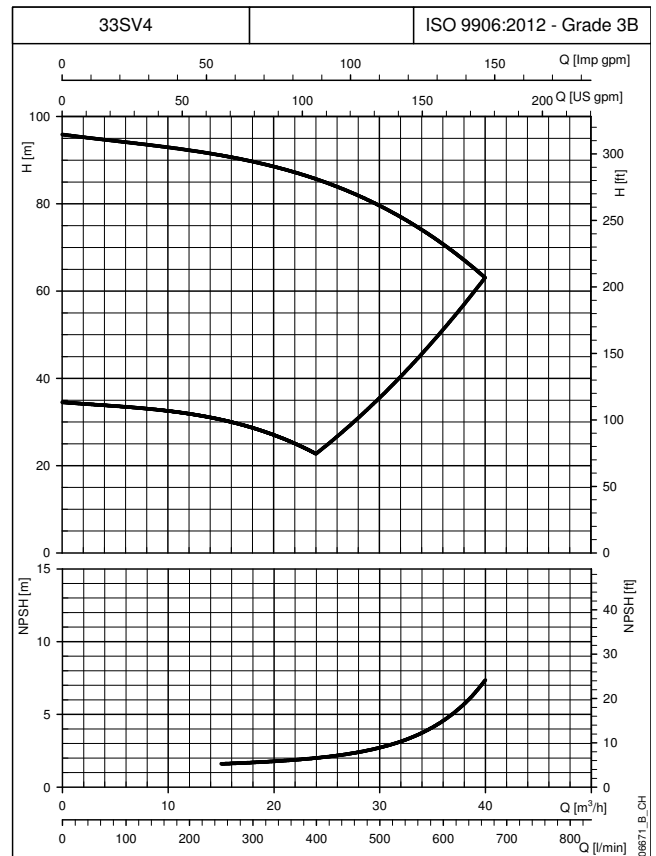
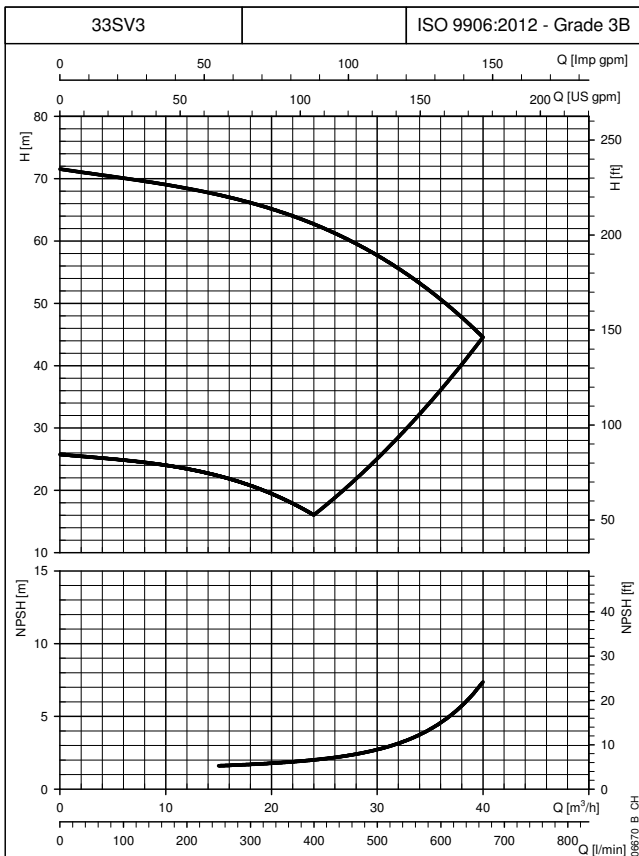
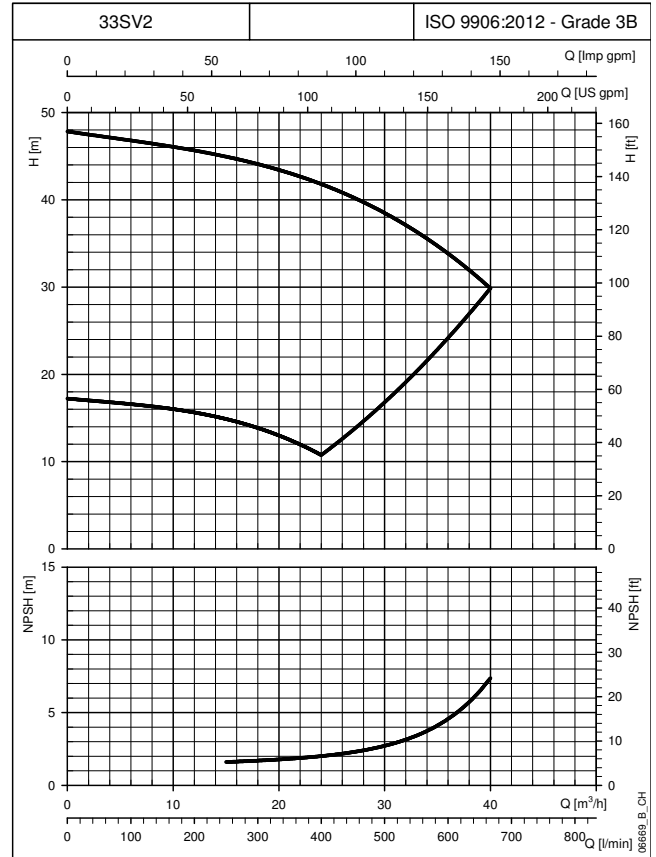
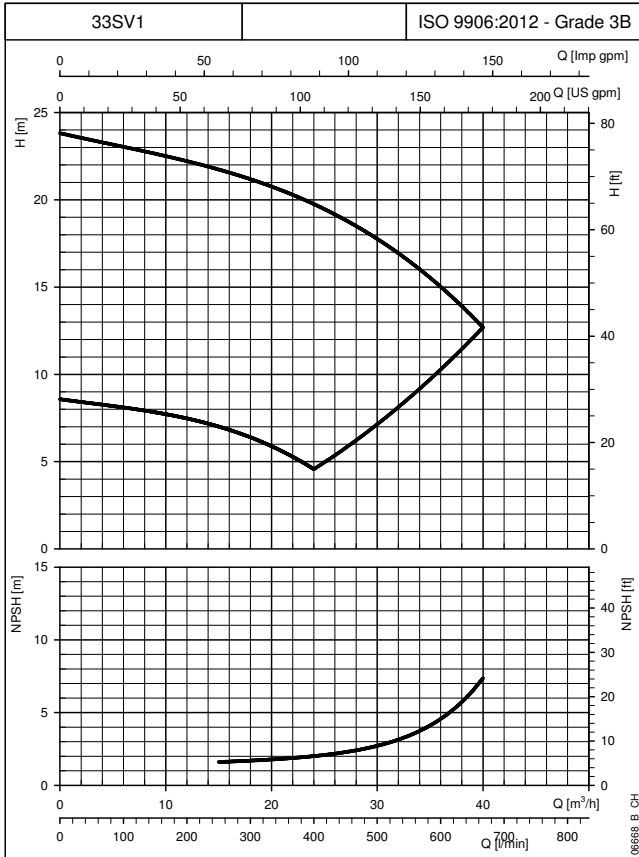

The curves show the performance with one pump running to the minimum and maximum speed. These performances are valid for liquids with density $\rho = 1.0 \text{ Kg/dm}^3$ and kinematic viscosity $\nu = 1 \text{ mm}^2/\text{s}$.

**33SVH SERIES
OPERATING CHARACTERISTICS AT 30..50 Hz**

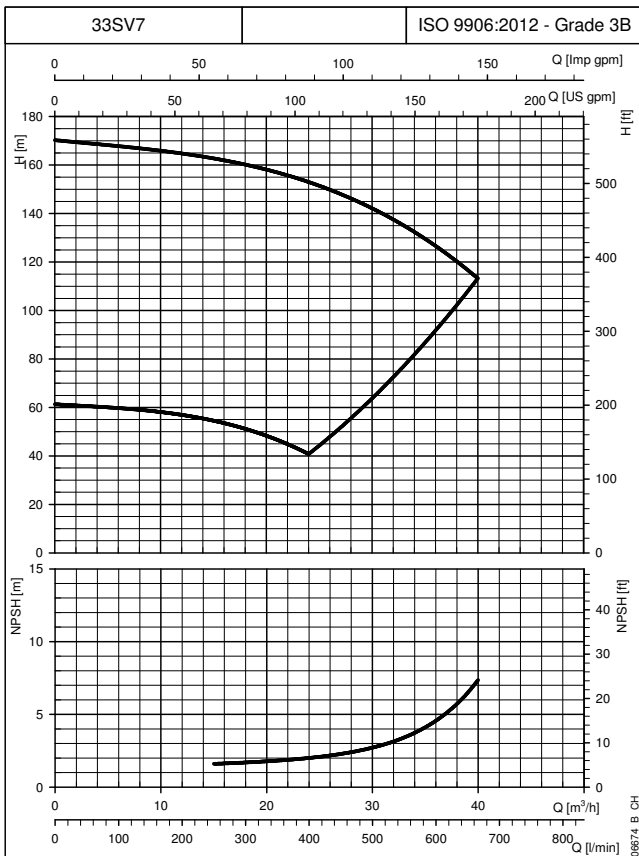
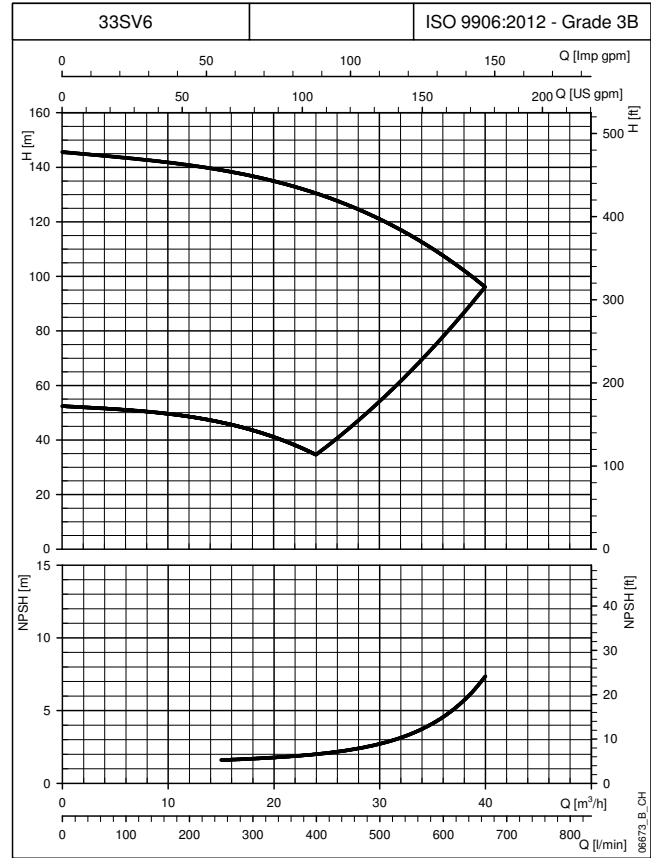
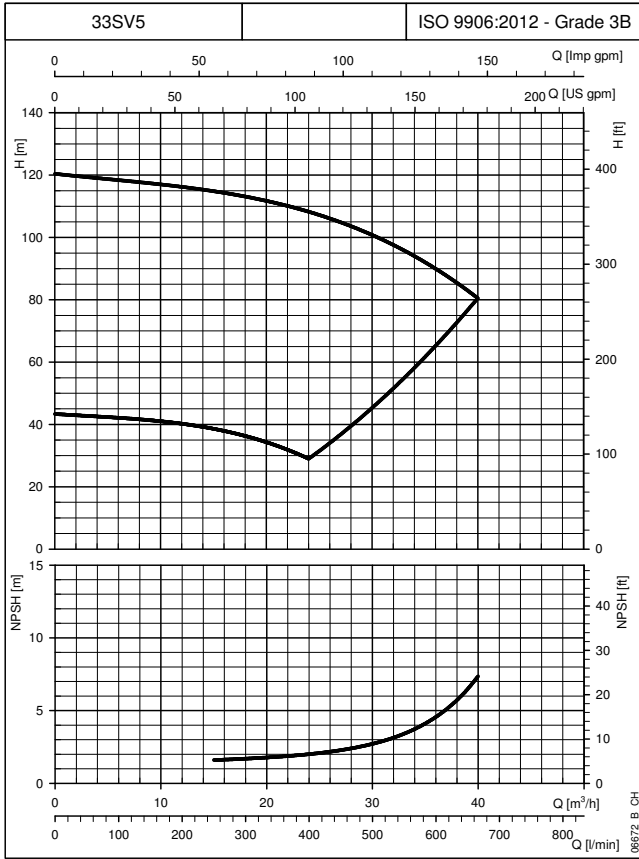

The curves show the performance with one pump running to the minimum and maximum speed. These performances are valid for liquids with density $\rho = 1.0 \text{ Kg/dm}^3$ and kinematic viscosity $\nu = 1 \text{ mm}^2/\text{s}$.

46SVH SERIES OPERATING CHARACTERISTICS AT 30..50 Hz

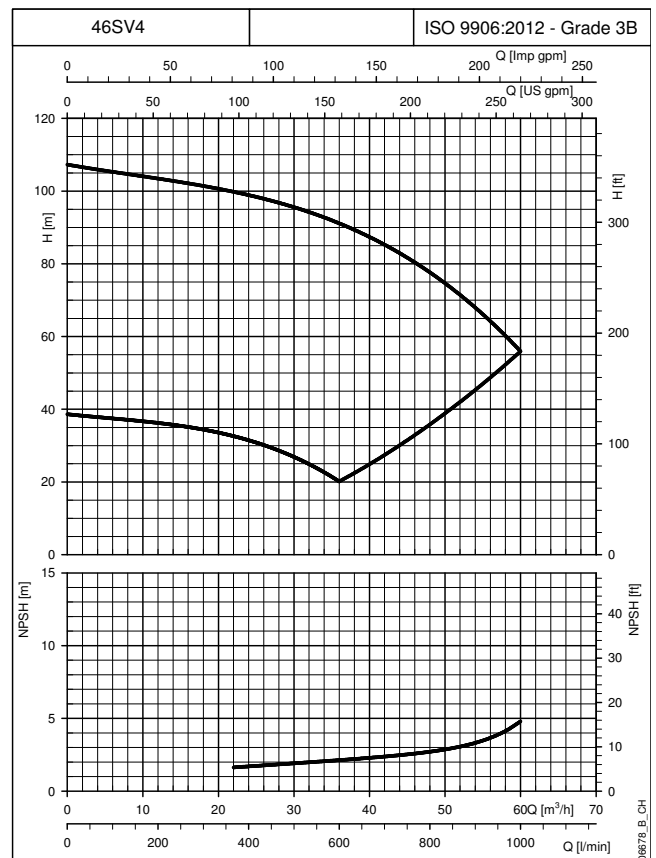
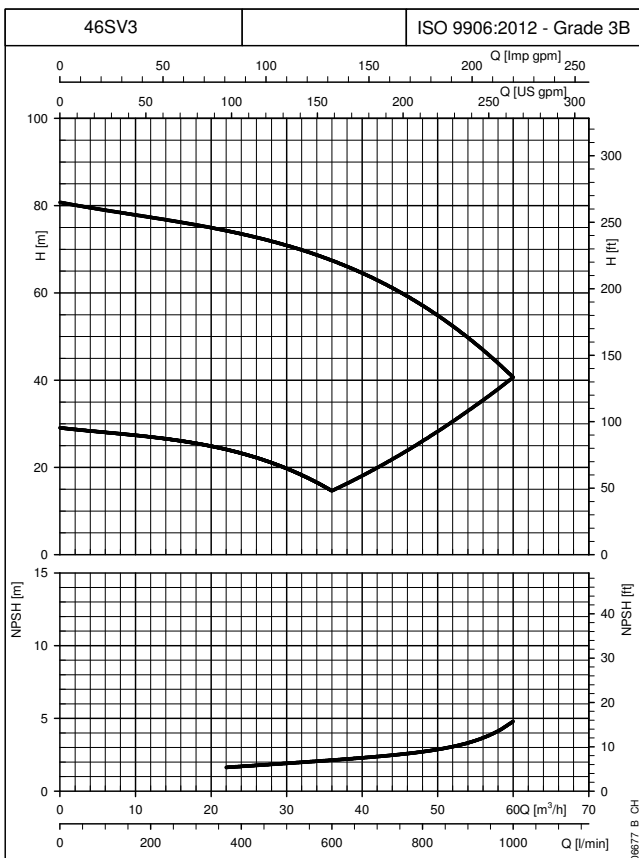
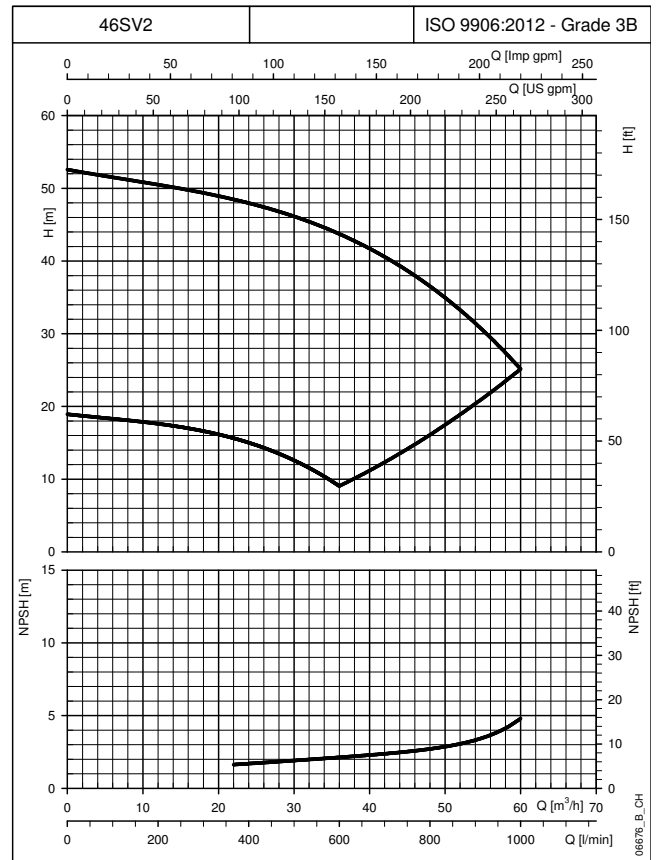
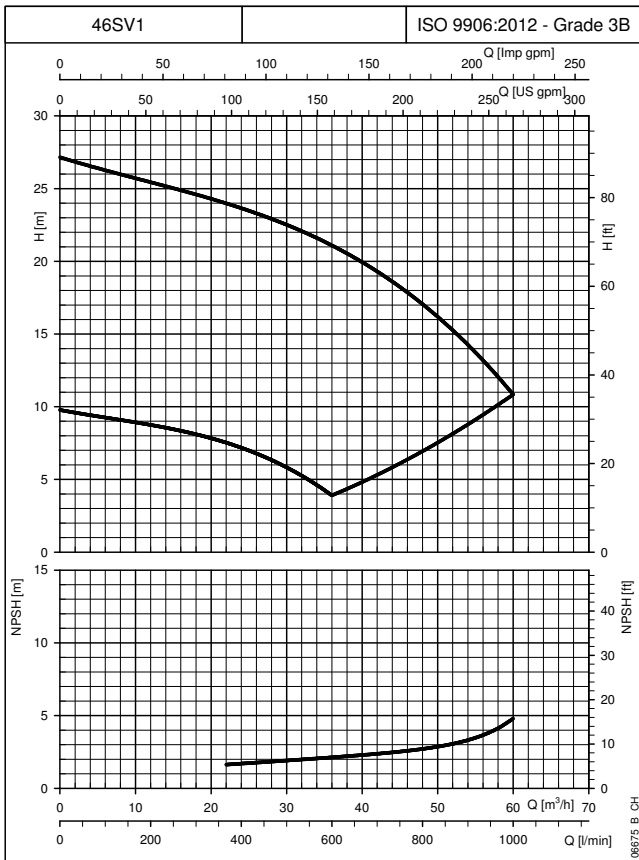

The curves show the performance with one pump running to the minimum and maximum speed. These performances are valid for liquids with density $\rho = 1.0 \text{ Kg/dm}^3$ and kinematic viscosity $\nu = 1 \text{ mm}^2/\text{s}$.

**46SVH SERIES
OPERATING CHARACTERISTICS AT 30..50 Hz**

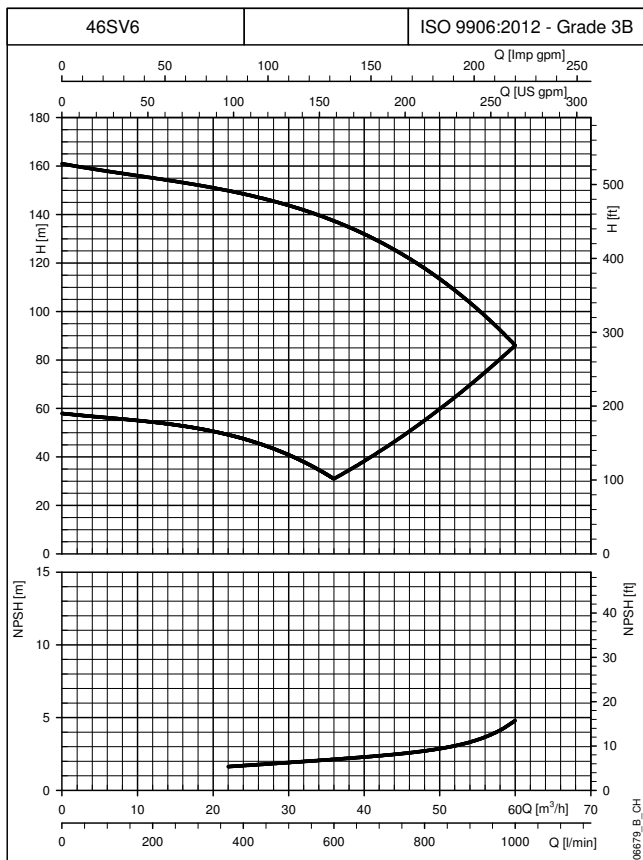

The curves show the performance with one pump running to the minimum and maximum speed.
These performances are valid for liquids with density $\rho = 1.0 \text{ Kg/dm}^3$ and kinematic viscosity $\nu = 1 \text{ mm}^2/\text{s}$.

66SVH SERIES OPERATING CHARACTERISTICS AT 30..50 Hz

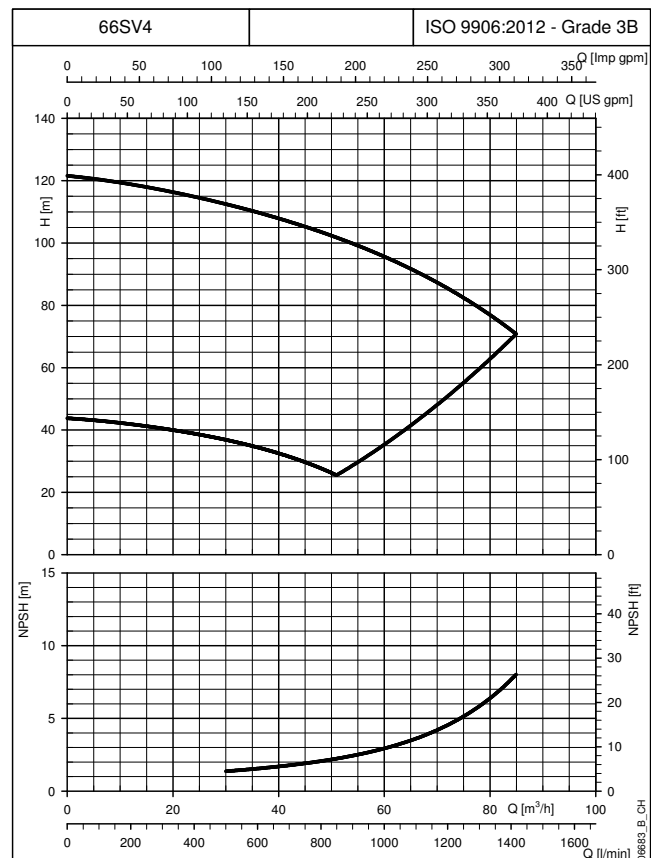
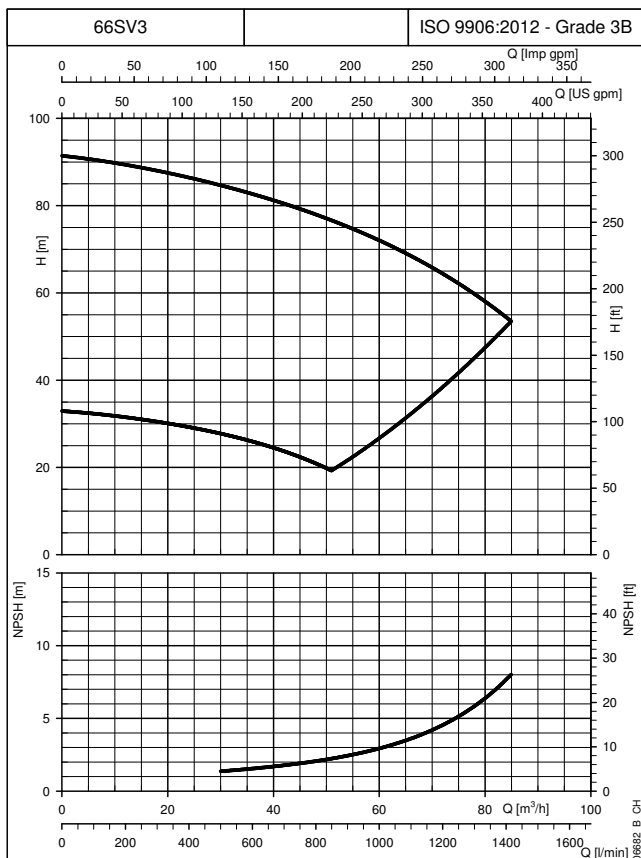
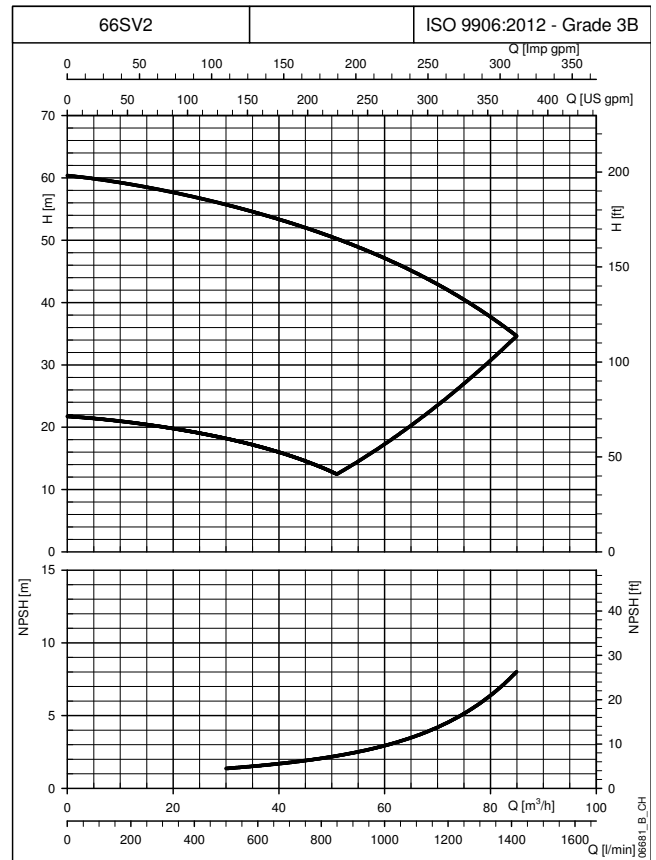
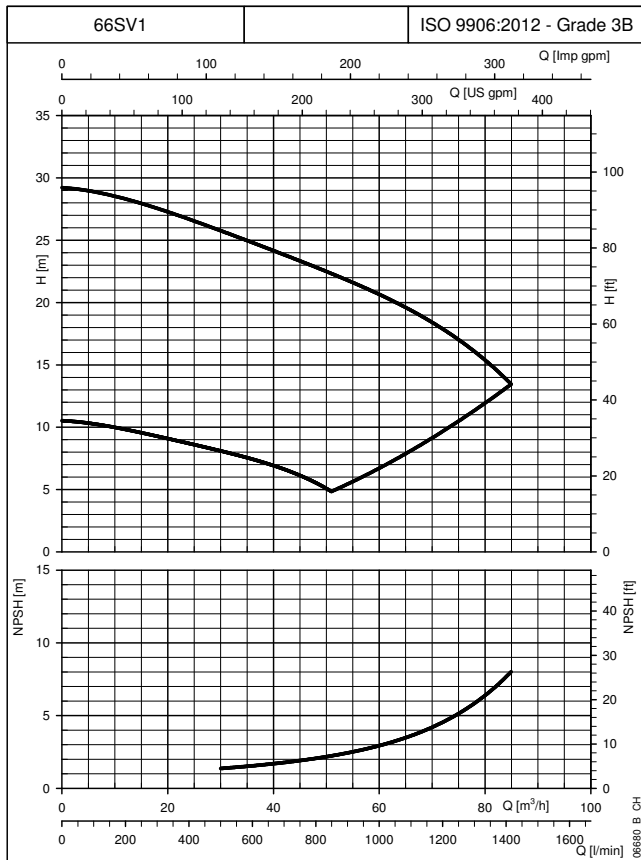

The curves show the performance with one pump running to the minimum and maximum speed. These performances are valid for liquids with density $\rho = 1.0 \text{ Kg/dm}^3$ and kinematic viscosity $\nu = 1 \text{ mm}^2/\text{s}$.

92SVH SERIES OPERATING CHARACTERISTICS AT 30..50 Hz

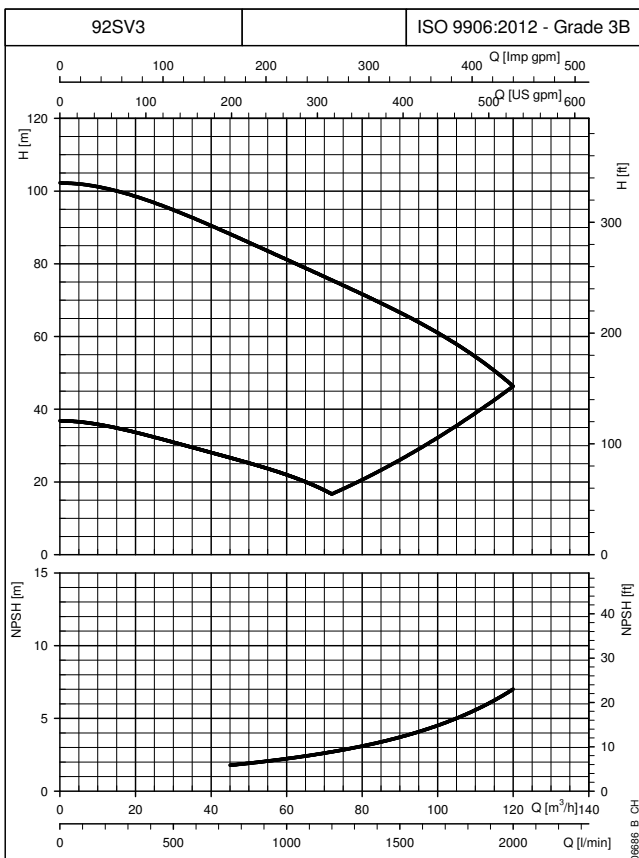
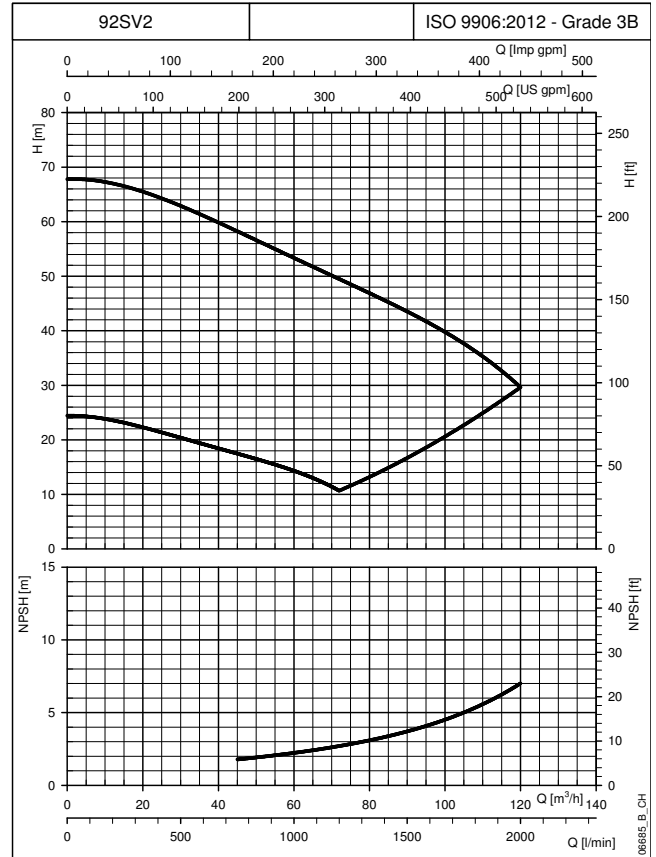
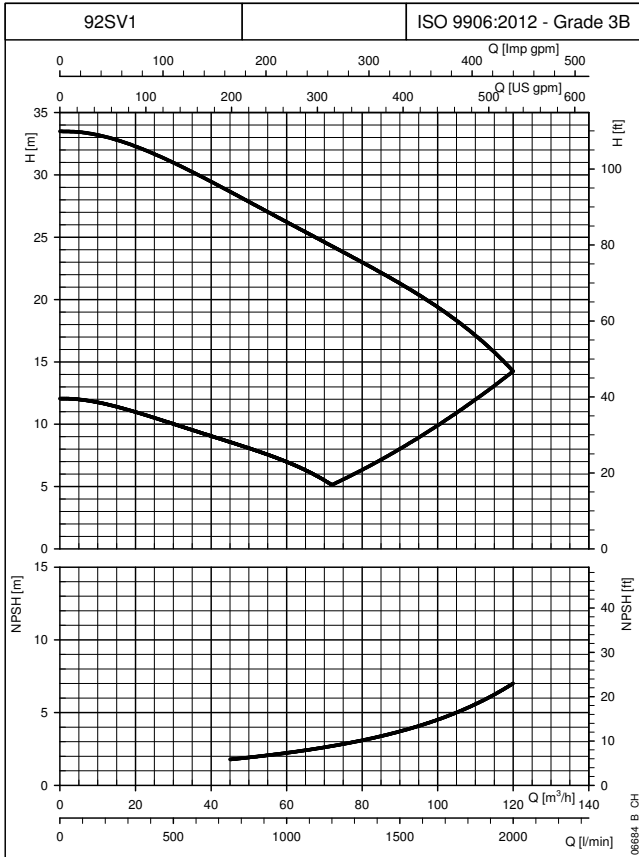

The curves show the performance with one pump running to the minimum and maximum speed. These performances are valid for liquids with density $\rho = 1.0 \text{ Kg/dm}^3$ and kinematic viscosity $\nu = 1 \text{ mm}^2/\text{s}$.

HYDROVAR HVL (WALL MOUNTING KIT) DIMENSIONS AND WEIGHTS

As an option a HYDROVAR wall mounting kit is also available, this is used where mounting on the pump unit is impossible or where you would like the controls in another location, these are available for the new generation HYDROVAR HVL 2.015-4.220 (22 kW). The speed of the cooling fan modulates with the HYDROVAR usage which optimizes energy consumption and also reduces noise.

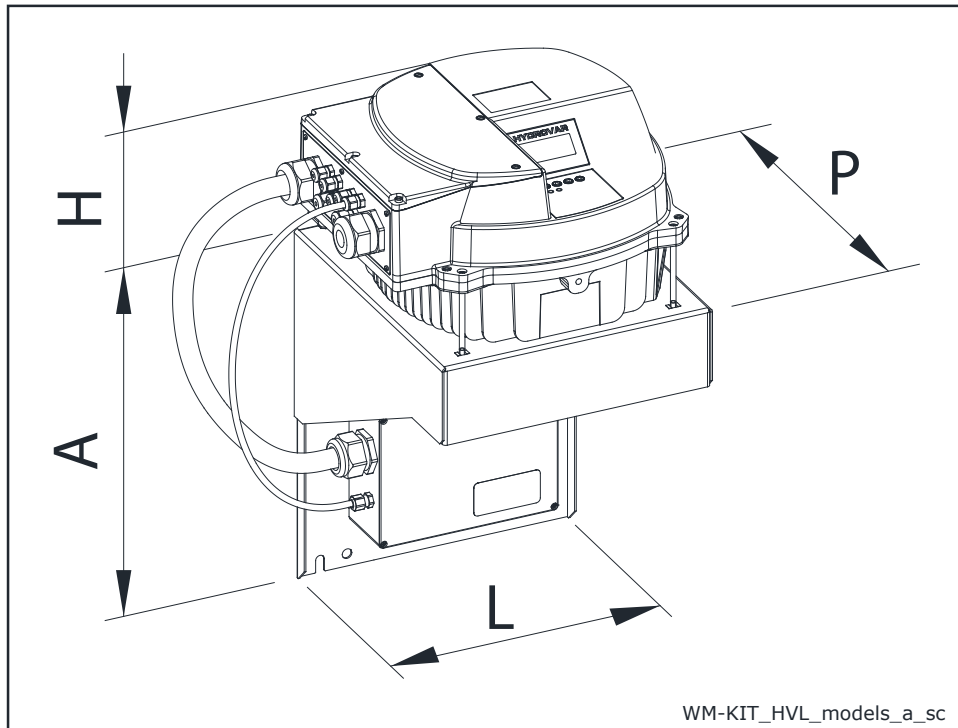

WM KIT TYPE	kW	WM KIT POWER SUPPLY	HVL SIZE	DIMENSIONS (mm)				WEIGHT (kg)	
				A	H	L	P	HVL	WM KIT
WM KIT HVL 2.015	1,5	1~ 230V	A	220	170	202	232	5,6	2,6
WM KIT HVL 2.022	2,2			220	170	202	232	5,6	2,6
WM KIT HVL 2.030	3		B	240	175	258	290	10,5	8,2
WM KIT HVL 2.040	4			320	175	288	305	10,5	5,4
WM KIT HVL 3.015	1,5	3~ 230V	A	220	170	202	232	5,6	2,6
WM KIT HVL 3.022	2,2			220	170	202	232	5,6	2,6
WM KIT HVL 3.030	3		B	240	175	258	290	10,5	8,2
WM KIT HVL 3.040	4			240	175	258	290	10,5	8,2
WM KIT HVL 3.055	5,5		C	240	175	258	290	10,5	8,2
WM KIT HVL 3.075	7,5			400	200	325	365	15,6	11,6
WM KIT HVL 3.110	11		400	200	325	365	15,6	11,6	
WM KIT HVL 4.015	1,5		3~ 400V	A	240	170	258	290	5,6
WM KIT HVL 4.022	2,2	240			170	258	290	5,6	8,2
WM KIT HVL 4.030	3	240			170	258	290	5,6	8,2
WM KIT HVL 4.040	4	240			170	258	290	5,6	8,2
WM KIT HVL 4.055	5,5	B		240	175	258	290	10,5	8,2
WM KIT HVL 4.075	7,5			240	175	258	290	10,5	8,2
WM KIT HVL 4.110	11	C		320	175	288	305	10,5	5,4
WM KIT HVL 4.150	15			400	200	325	365	15,6	11,6
WM KIT HVL 4.185	18,5			400	200	325	365	15,6	11,6
WM KIT HVL 4.220	22			400	200	325	365	15,6	11,6

WM-KIT_HVL_models-EN_b_td

Xylem |'zīləm|

- 1) The tissue in plants that brings water upward from the roots;
- 2) a leading global water technology company.

We're a global team unified in a common purpose: creating innovative solutions to meet our world's water needs. Developing new technologies that will improve the way water is used, conserved, and re-used in the future is central to our work. We move, treat, analyze, and return water to the environment, and we help people use water efficiently, in their homes, buildings, factories and farms. In more than 150 countries, we have strong, long-standing relationships with customers who know us for our powerful combination of leading product brands and applications expertise, backed by a legacy of innovation.

For more information on how Xylem can help you, go to xylem.com.



Legal head office
Xylem Water Solutions Italia Srl

Via Gioacchino Rossini 1/A
20020 - Lainate (MI) - Italy
Tel. (+39) 02 90358.1
Fax (+39) 02 9019990
www.xylemwatersolutions.com

For information and technical support
Xylem Service Italia Srl

Via Dottor Vittorio Lombardi 14
36075 - Montecchio Maggiore (VI) - Italy
Tel. (+39) 0444 707111
Fax (+39) 0444 491043
www.lowara.com

Xylem Water Solutions Italia Srl reserves the right to make modification without prior notice.
Lowara, Xylem are trademarks of Xylem Inc. or one of its subsidiaries
© 2016 Xylem, Inc.