

Vista da A
View from A

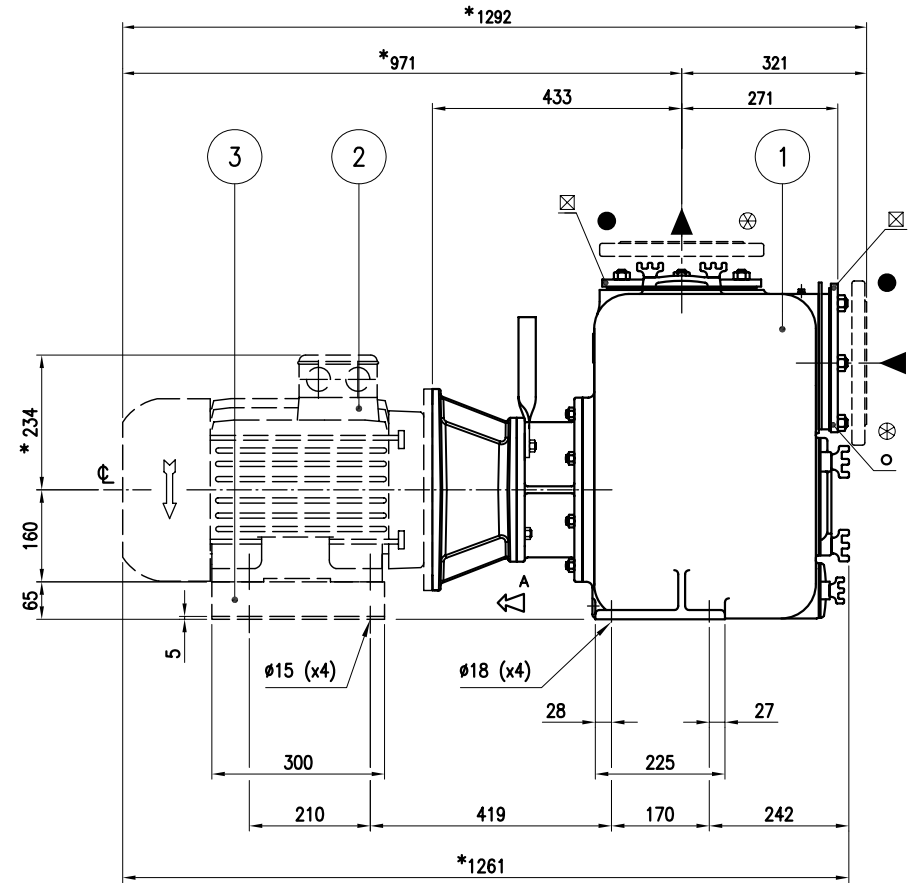

FLANGIATURA STANDARD
STANDARD FLANGES

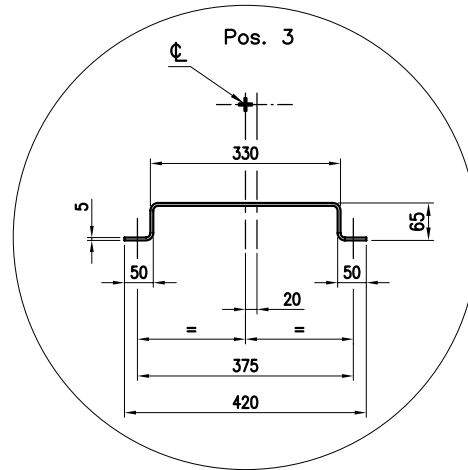
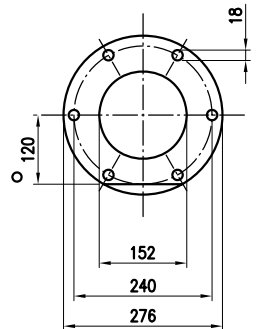

DN 150 D.I.1882 TL

FLANGIATURA SU RICHIESTA / FLANGES ON REQUEST

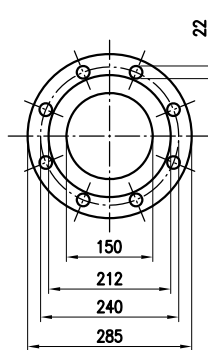

DN 150 PN 16 (+F)

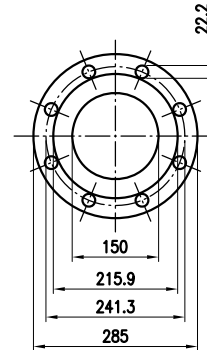

6" ASA 150 R.F. (+FA)

- * Dimensione indicativa: può variare in funzione della marca del motore utilizzato
- * Approximate dimension: it may change according to the motor make

3	PIEDE MOTORE/MOTOR BRACKET	VARISCO	330x300x65 sp.5	DIS. B80.0022	1
2	MOTORE ELETTRICO/A.C. MOTOR		IM B35 (IEC 60034)/160M	50 Hz/11 kW/4P	1
1	POMPA/PUMP	VARISCO	J 6-250		1
POS	DESCRIZIONE/DESCRIPTION	FORNITORE/SUPPLIER	TIPO/TYPE	NOTE/NOTES	Q

	Tipo / Type JP(E) 6-250 - - - ETO		Dis.n. / Dwg No. B3/26.000.K.13	
	Sost.it/Repl.N°	Sost.Dal/Repl.from	Ver.	
Codice / Code DIMENSIONI D'INGOMBRO / OVERALL DIMENSIONS			Dis.	11.12.2008
			Data / Date	Firma/Signature A.Gamba