

DISTINTA DELLE PARTI COSTITUENTI LE POMPE CENTRIFUGHE AUTOADESCANTI SERIE " J "
SPARE PARTS LIST FOR "J" SERIES SELF-PRIMING PUMPS
LISTE DES PIECES DE RECHANGE POUR POMPES CENTRIFUGES AUTO-AMORCANTES SERIE "J"
ERSATZTEILLISTE FÜR SELBSTANSAUGENDE KREISELPUMPEN SERIE "J"

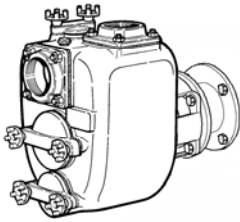

JP 3-210 G10 ETO	Code 1004 0888
JP 3-210 B10 ETO	Code 1004 6433
JP 3-210 Q10 ETO	Code 1004 6435
JP 3-210 F10 ETO	Code 1004 6436
JP 3-210 P10 ETO	Code 1004 6434
JP 3-210 T10 ETO	Code 1004 6437
JP 3-210 S10 ETO	Code 1004 6438
JP 3-210 R10 ETO	Code 1004 6439

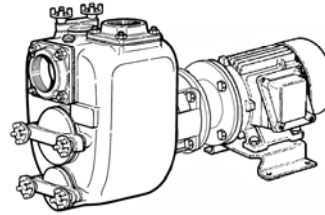

JE 3-210 G10 ETO	Code 1004 2934
JE 3-210 B10 ETO	Code 1004 6396
JE 3-210 Q10 ETO	Code 1004 6397
JE 3-210 F10 ETO	Code 1004 6398
JE 3-210 P10 ETO	Code 1004 6399
JE 3-210 T10 ETO	Code 1004 6400
JE 3-210 S10 ETO	Code 1004 6401
JE 3-210 R10 ETO	Code 1004 6402

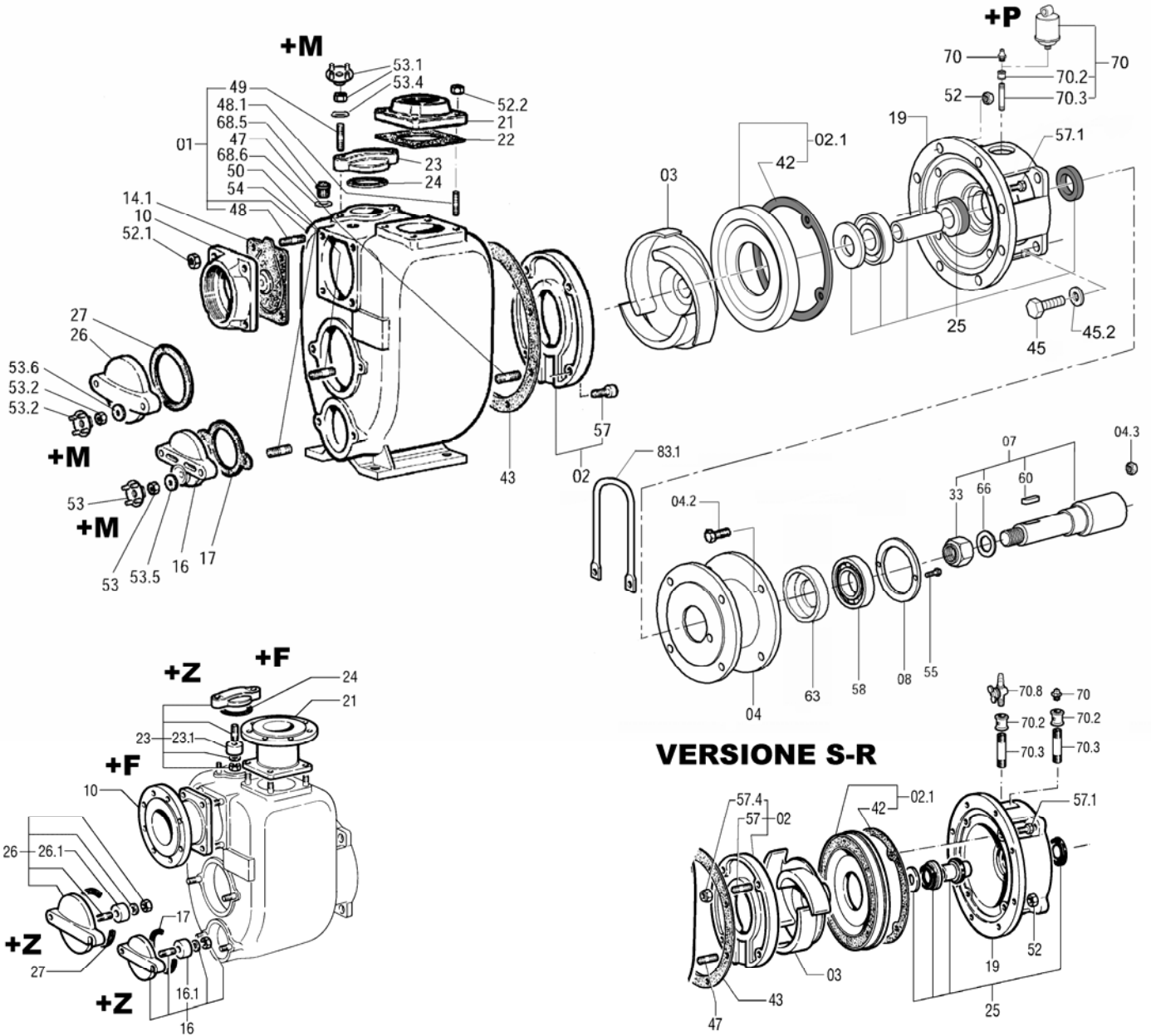

+ = OPTIONAL

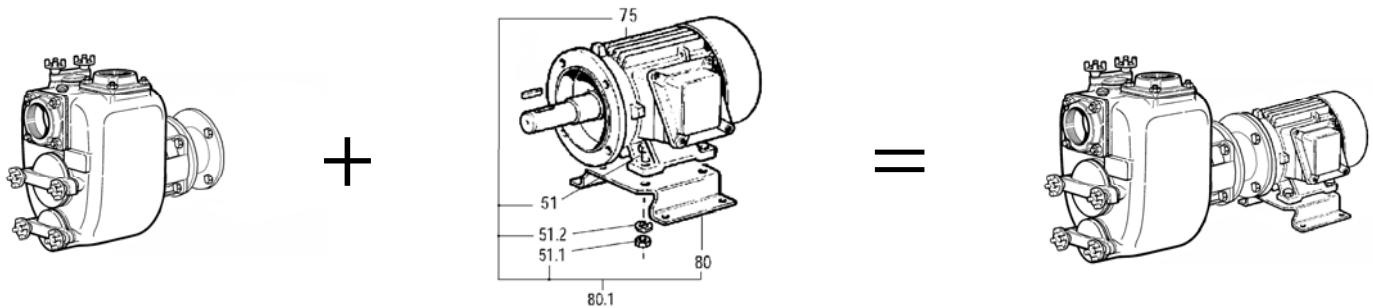

JP + MOTORE / MOTOR = JE

Rif. N°. Pos. Nr. Ref. no. Réf. N°.	Quant.	Denominazione	Part name	Den. Comm. Type	Mat.*	Codice Nuovo New Part. no.	JP 3-210 G10	JP 3-210 B10	JP 3-210 Q10	JP 3-210 F10	JP 3-210 P10	JP 3-210 T10	JP 3-210 S10	JP 3-210 R10		
01	1	Corpo (1)	Casing (1)		G	1000 8034	○				○					
					B	1000 8026		○								
					G	1002 7654			○	○						
					G+QPQ	1002 4663								○		
					G	1002 0155									○	
					G+QPQ	1004 6404										○
02	1	Piatto d'usura (2)	Wear plate (2)		G	1000 8415				○	○			○		
					GN	1000 8439	○									
					B	1000 8402		○	○							
					G+QPQ	1002 8399								○		
02.1	1	Piatto poggia girante (4)	Wear plate (4)		GN	1002 0154							○	○		
					G	1000 8416				○	○					
					GN	1000 8440	○							○	○	
					B	1000 8403		○	○							
03	1	Girante	Impeller		G+QPQ	1002 5866						○				
					G	1000 8416				○	○					
					GN	1000 8440	○							○	○	
					B	1000 8403		○	○							
					G+QPQ	1002 5866									○	
04	1	Campana	Coupling flange		G	1000 5291	○				○					
					B	1000 5203		○	○							
					G+QPQ	1001 8615							○			
					S	1000 5382								○		
					S+QPQ	1002 7048									○	
04.2	4	Vite	Screw	M 12 x 45 DIN 933	K	1000 5394			○				○			
					S		○	○	○	○	○	○	○	○		
04.3	4	Dado	Nut	M 12 DIN 125A	K			○	○	○	○	○	○			
					S		○	○	○	○	○	○	○			
07	1	Albero (5)	Shaft (5)		K	1004 3211		○	○	○			○			
					S	1004 0886	○				○	○	○	○		
08	1	Copricuscinetto	Bearing cover		G	1004 0883	○	○	○	○	○	○	○			
10	1	Portavalvola	Suction flange	R 3"	G	1000 6422	○			○	○	○	○	○		
					OTS	1000 6399		○	○							
14.1	1	Valvola completa	Check valve ass.		NH	1000 9019	○	○					○	○		
					VK	1000 9022			○	○	○					
16	1	Portina	Cover		G	1000 6474	○			○	○	○	○	○		
					GZ	1000 8503			○							
					OTS	1000 3749		○								
					GZ	1000 8503										
16.1	2	Placca zinco	Zinc anode		Z	1000 3810										
17 (**)	1	Guarnizione	Gasket													
19	1	Portamotore	Head		G	1000 6305	○		○	○	○					
					G	1000 6317								○		
					B	1000 6283		○								
					G+QPQ	1002 4686								○		
					G+QPQ	1002 7049									○	
21	1	Flangia mandata	Discharge flange	R 3"	G	1000 5090	○			○	○	○	○	○		
					OTS	1000 5070		○	○							
22 (**)	1	Guarnizione	Gasket													

VARISCO S.p.A.

Terza Strada, 9 - Z.I. Nord - 35129 Padova - Italy

Tel. 049 82 94 111

+39 049 82 94 111

Fax 049 82 94 373

International +39 049 80 76 762

varisco
solid pumping solutions

Rif. N°. Pos. Nr. Ref. no. Réf. N°.	Quant.	Denominazione	Part name	Den. Comm. Type	Mat.*	Codice Nuovo New Part. no.	JP 3-210 G10	JP 3-210 B10	JP 3-210 Q10	JP 3-210 F10	JP 3-210 P10	JP 3-210 T10	JP 3-210 S10	JP 3-210 R10	
23	1	Portina	Cover		S	1000 6473	○			○	○				
					G	1000 6486									
					SZ	1000 8502			○						
					B	1000 3748			○						
					SZ	1000 8502	+Z							+Z	+Z
23.1	1	Placca zinco	Zinc anode		Z	1000 3810	+Z				+Z	+Z	+Z		
24 (**)	1	Guarnizione	Gasket												
25	1	Anello di tenuta compl.	Mechanical seal ass.	T35 YWN		1000 8836	○	○				○	○	○	
				T35 YVY		1000 8834			○	○	○				
26	1	Portina	Cover		G	1000 6475	○			○	○	○	○	○	
					GZ	1000 8504			○						
					B	1000 6468			○						
					GZ		+Z						+Z	+Z	+Z
26.1	2	Placca zinco	Zinc anode		Z	1000 3810	+Z				+Z	+Z	+Z		
27 (**)	1	Guarnizione	Gasket												
33	1	Dado blocca girante	Impeller nut	M 24 x 2 UNI 7474	H	1000 1465	○				○	○	○	○	
				M 24 x 2 UNI 7474	K	1000 1472		○	○	○					
42 (**)	1	Guarnizione piatto	Wear plate gasket												
43 (**)	2	Guarnizione corpo	Casing gasket												
45	4	Vite	Screw	M 12 x 30 DIN 933	S	1000 1960	○				○	○	○	○	
				M 12 x 30 DIN 933	K	1000 1960		○	○	○				○	
45.2	4	Rondella	Washer	M 12 DIN 125A	S	1000 1699	○				○	○	○	○	
					K	1000 1706		○	○	○					
47 (*)	8	Prigioniero	Stud	M 10 x 25 DIN 938	S		○				○	○	○	○	
				M 10 x 25 DIN 938	K			○	○	○					
48 (*)	4	Prigioniero	Stud	M 10 x 25 DIN 938	S		○				○	○	○	○	
				M 10 x 25 DIN 938	K			○	○	○					
48.1 (*)	4	Prigioniero	Stud	M 10 x 25 DIN 938	S		○				○	○	○	○	
				M 10 x 25 DIN 938	K			○	○	○					
49 (*)	4	Prigioniero	Stud	M 10 x 30 DIN 938	S		○				○	○	○	○	
				M 10 x 30 DIN 938	K			○	○	○					
50 (*)	2	Prigioniero	Stud	M 12 x 35 DIN 938	S		○				○		○	○	
				M 12 x 35 DIN 938	K			○	○	○					
51.1	4	Dado	Nut	M 10 DIN 934	S	1000 1421	○	○	○	○	○	○	○		
51.2	4	Rondella	Washer	M 10 DIN 125 A	S	1000 1691	○	○	○	○	○	○	○		
52 (*)	8	Dado	Nut	M 10 DIN 934	S		○				○		○	○	
					H			○	○	○					
52.1 (*)	4	Dado	Nut	M 10 DIN 934	S		○				○	○	○	○	
					H			○	○	○					
52.2 (*)	4	Dado	Nut	M 10 DIN 934	S		○				○	○	○	○	
					H			○	○	○					
53 (*)	2	Dado	Nut	M 10 DIN 934	S		○				○	○	○	○	
					H				○	○					
53.1 (*)	2	Dado	Nut	M 10 DIN 934	S		○				○	○	○	○	
					H					○					
	2	Maniglietta	Wrench	M 10	OTS		+M	○	○			+M	+M	+M	
53.2 (*)	2	Dado	Nut	M 12 DIN 934	S		○				○	○	○	○	
					H						○				
	2	Maniglietta	Wrench	M 12	OTS		+M	○	○			+M	+M	+M	
53.4 (*)	4	Rondella	Washer	M 10 DIN 125 A	S		○				○	○	○	○	
					H						○				
53.5 (*)	2	Rondella	Washer	M 10 DIN 125 A	S		○				○	○	○	○	
					H						○				
53.6 (*)	2	Rondella	Washer	M 12 DIN 125 A	S		○				○	○	○	○	
					H						○				
54 (*)	2	Prigioniero	Stud	M 10 x 30 DIN 938	S		○				○		○	○	
					K					○	○	○			
55	4	Vite	Screw	M 6 x 20 DIN 933	S	1000 1932	○	○	○	○	○	○	○	○	
57 (*)	4	Vite	Screw	M 10 x 20 DIN 912	H		○				○	○		○	
					K					○	○	○			
		Prigioniero	Stud	M 10 x 30 DIN 938	K							○			

VARISCO S.p.A.

Terza Strada, 9 - Z.I. Nord - 35129 Padova - Italy

Tel. 049 82 94 111

+39 049 82 94 111

Fax 049 82 94 373

International +39 049 80 76 762

varisco
solid pumping solutions

Rif. N°. Pos. Nr. Ref. no. Réf. N°.	Quant.	Denominazione	Part name	Den. Comm. Type	Mat.*	Codice Nuovo New Part. no.	JP 3-210 G10	JP 3-210 B10	JP 3-210 Q10	JP 3-210 F10	JP 3-210 P10	JP 3-210 T10	JP 3-210 S10	JP 3-210 R10	
57.1 (*)	4	Vite	Screw	M 10 x 25 DIN 938	S		○				○	○		○	
				M 10 x 35 DIN 933	S								○		
				M 10 x 25 DIN 938	K			○	○	○					
57.4	4	Dado	Nut	M 10 UNI 7474	K							○	○		
58	1	Cuscinetto	Ball bearing	6307 Z		1000 1376	○	○	○	○	○	○	○	○	
60	1	Linguetta	Key	8 x 7 x 32 DIN6885A	K	1000 1624	○	○	○	○	○	○	○	○	
63	1	Ghiera	Lock ring		S	1004 0884	○	○	○	○	○	○	○	○	
66	1	Rondella	Washer	M 24 DIN 125 A	H	1000 1714	○				○	○	○	○	
				M 24 DIN 125 A	K	1000 1713		○	○	○					
68.5 (*)	1	Tappo	Plug	1/4"	S		○		○		○	○	○	○	
					K			○		○					
68.6	1	Guarnizione	Gasket	1/4" DIN 908 SP. 1,5	D	1000 5657		○	○						
70	1	Ingrassatore	Grease nipple	1/4"		1000 1662	○	○	○	○	○	○	○	○	
		Cartuccia Perma	Perma cartridge	1/4"		1000 8316	+P	+P	+P	+P	+P	+P	+P	+P	
70.2 (*)	1	Manicotto	Union	1/4"	S		+P	+P	+P	+P	+P	+P	+P	+P	
	2														○
70.3 (*)	1	Prolunga	Grease tube	1/4"	S		+P	+P	+P	+P	+P	+P	+P	+P	
				1/4" x 75											○
70.8 (*)	1	Rubinetto lava tenuta	Flushing of the seal	1/4"									○		
75	1	Motore V.230-400(3Ph)	A.C. Motor V.230-400(3Ph)	4 kW - 4P - 230V		1004 2944	○	○	○	○	○	○	○	○	
80	1	Piede motore	Motor base		S	1000 7427	○	○	○	○	○	○	○	○	
80.1	1	Kit piede motore	Electric motor foot			1004 3177	○	○	○	○	○	○	○	○	
83.1	1	Gancio di sollevam.	Lifting hook		S	1000 7396	○	○	○	○	○	○	○	○	
(*)		Serie viterie	Set of screws			1001 4161	○				○	○			
						1001 4163							○	○	
						1001 4192					○				
						1001 4176		○	○						
(**)		Serie guarnizioni	Set of gaskets			1001 4162	○					○	○	○	
						1001 4193					○	○			
						1004 4061				○					
						1001 4473		○							
+F***		Kit flange	Kit flange	DN 80 PN16	G	1004 2810	○			○	○	○	○	○	
				DN 80 PN16	B	1004 2806		○	○						
				3" ASA150	G	1004 2819	○			○		○	○		
				3" ASA150	B	1004 2823		○			○				
+D***		Kit ingrassatore	Compl. Grease kit			1000 8316	○	○	○	○	○	○	○		
+Z***		Kit portine	Set of couver		GZ	1001 4385	○				○	○	○		
+M***		Kit manigliette	Set of wrench		OTS	1004 2795	○				○	○	○		
***		Optional													

Note:	Notes:
1) Completo di prigionieri (47, 48, 49,54) e tappi (68.5 e 68.8).	1) Complete with studs (47, 48, 49, 54) and plugs (68.5 and 68.8).
2) Completo di viti (57).	2) Complete with screws (57).
3) Completo di prigioniero (57) e dado (57.4).	3) Complete with studs (57) and nuts (57.4).
4) Completo di guarnizione (42).	4) Complete with gasket (42).
5) Completo di dado (33), linguette (60, 61), ghiera (62), rondella (66) e spartiacque (34).	5) Complete with nut (33), keys (60,61), sleeve (62), washer (62) and water deflector (34).
* M materiali di costruzione	* Construction materials
B = Bronzo	B = Bronze
D = Guarnital	D = Guarnital
G = Ghisa	G = Cast iron
G+QPQ = Ghisa+QPQ	G+QPQ = Cast iron+Quench Polish Quench
H = Acciaio INOX AISI 304	H = AISI 304 Stainless steel
K = Acciaio INOX AISI 316	K = AISI 316 Stainless steel
N = Gomma nitrile	N = Nitrile rubber
OTS = Ottone	OTS = Brass
S = Acciaio	S = Steel
S+QPQ = Acciaio+QPQ	S+QPQ = Steel+Quench Polish Quench
V = Viton	V = Viton
Z = Zinco	Z = Zinc
Ordinare il materiale indicando sempre la quantità, la denominazione, il codice del pezzo, il tipo ed il numero della pompa.	When ordering spares always indicate type and serial number of pump, quantity, part name, and number.

VARISCO S.p.A.

Terza Strada, 9 - Z.I. Nord - 35129 Padova - Italy

Tel. 049 82 94 111

+39 049 82 94 111

Fax 049 82 94 373

International +39 049 80 76 762

