

**DISTINTA DELLE PARTI COSTITUENTI LE POMPE CENTRIFUGHE AUTOADESCANTI SERIE " J "**  
**SPARE PARTS LIST FOR "J" SERIES SELF-PRIMING PUMPS**  
**LISTE DES PIECES DE RECHANGE POUR POMPES CENTRIFUGES AUTO-AMORCANTES SERIE " J "**  
**ERSATZTEILLISTE FÜR SELBSTANSAUGENDE KREISELPUMPEN SERIE " J "**

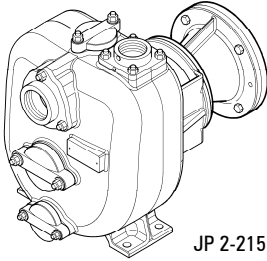

JP 2-215 G10 Code 1004 5699

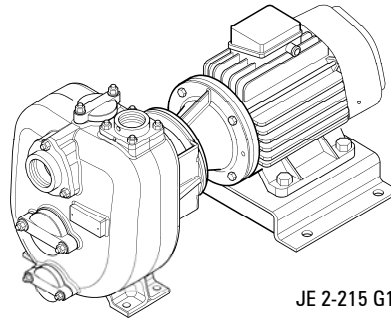

JE 2-215 G10 ET20 Code 1004 5708

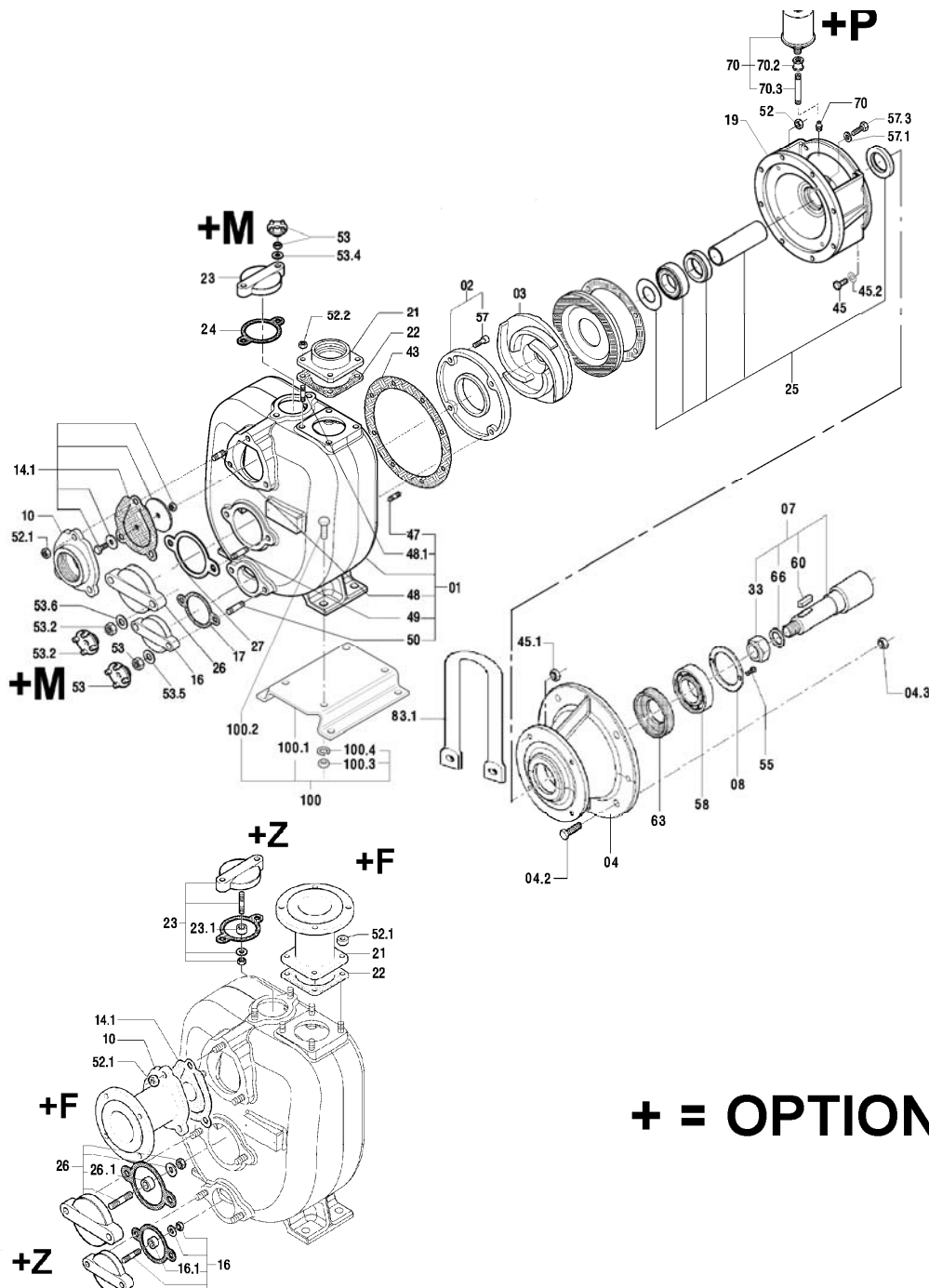

**+ = OPTIONAL**

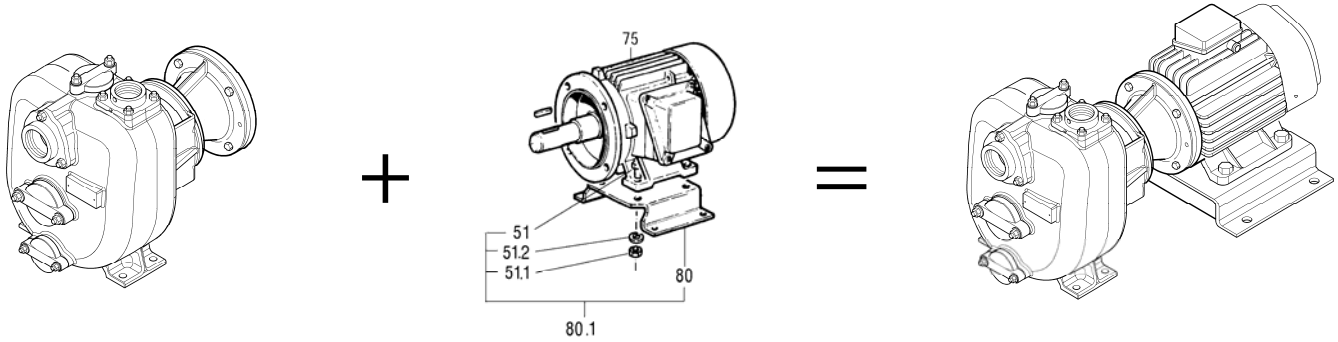

JP + MOTORE / MOTOR = JE

Rif. N° Pos. Nr.	Quant.	Denominazione	Part name	Den. Comm. Type	Mat. *	Codice Nuovo New Part. No.	JP 2-215 G10 ETO
01	1	Corpo (1)	Casing (1)		GS	1004 7668	○
02	1	Piatto d' usura (2)	Wear plate (2)		GN	1004 7670	○
02.1	1	Piatto d' usura (3)	Wear plate (3)		GN	1004 7671	○
03	1	Girante	Impeller		GS	1004 4620	○
04	1	Campana	Coupling flange		G	1004 0868	○
04.2	4	Vite	Screw	M 16 x 50 DIN 933	S	1000 1975	○
04.3	4	Dado	Nut	M 16 DIN 934	S	1000 1425	○
07	1	Albero (5)	Shaft (5)		S	1004 5697	○
08	1	Copricuscinetto	Bearing cover		G	1004 0857	○
10	1	Portavalvola	Suction flange	R 2"	G	1000 6417	○ +F
14.1	1	Valvola completa	Check valve ass.		NH	1000 9015	○
16	1	Portina	Cover		G	1000 6473	○
					SZ	1000 8502	+Z
16.1	2	Placca zinco	Zinc anode		Z	1000 3810	+Z
17 (**)	2	Guarnizione	Gasket				
19	1	Portamotore	Head		G	1004 5498	○
21	1	Flangia mandata	Discharge flange	R 2"	G	1000 5085	○ +F
22 (**)	1	Guarnizione	Gasket				
23	1	Portina	Cover		S	1000 6474	○
					SZ	1000 8503	+Z
23.1	1	Placca zinco	Zinc anode				+Z
24	1	Guarnizione	Gasket				
25	1	Anello di tenuta	Mechanical seal ass.	T 35 YYN		1004 4630	○
33	1	Dado girante	Impeller nut	M 24 x 2 UNI 7474	H	1000 1465	○
42 (**)	1	Guarnizione piatto	Wear plate gasket				
43 (**)	1	Guarnizione corpo	Casing gasket				
45	4	Vite	Screw	M 12 x 35 DIN 933	S	1000 1961	○
45.1	4	Dado	Nut	M 12 DIN 934	S	1000 1422	○
45.2	4	Rondella	Washer	M 12 UNI1751/52	S	1000 1681	○
47 (*)	8	Prigioniero	Stud	M 10 x 25 DIN 938	S		○
48 (*)	3	Prigioniero	Stud	M 10 x 25 DIN 938	S		○
48.1 (*)	4	Prigioniero	Stud	M 10 x 25 DIN 938	S		○
49 (*)	2	Prigioniero	Stud	M 10 x 30 DIN 938	S		○
50	4	Prigioniero	Stud	M 10 x 30 DIN 938	S		○

VARISCO S.p.A.

Terza Strada, 9 - Z.I. Nord - 35129 Padova - Italy

Tel. 049 82 94 111

+39 049 82 94 111

Fax 049 82 94 373

International +39 049 80 76 762

**varisco**  
solid pumping solutions

Rif. N° Pos. Nr.	Quant.	Denominazione	Part name	Den. Comm. Type	Mat. *	Codice Nuovo New Part. No.	JP 2-215 G10 ETO
51	4	Vite	Screw	M 12 x 45 DIN 931	S	1000 1963	○
51.1	4	Dado	Nut	M 12 DIN 934		1000 1422	○
51.2	4	Rondella	Washer	M 12 DIN 125A		1000 1699	○
52 (*)	8	Dado	Nut	M 12 DIN 934	S		○
52.1(*)	4	Dado	Nut	M 10 DIN 934	S		○
52.2(*)	4	Dado	Nut	M 10 DIN 934	S		○
53 (*)	4	Dado	Nut	M 10 DIN 934	S		○
		Maniglietta	Wrench	M 10	OTS		+M
53.2 (*)	2	Dado	Nut	M 10 DIN 934	S		○
		Maniglietta	Wrench	M 10	OTS		+M
53.4(*)	2	Rondella	Washer	M 10 DIN 125 A	S		○
53.5(*)	2	Rondella	Washer	M 10 DIN 125 A	S		○
55	4	Vite	Screw	M 6x25 DIN 933	S	1002 8349	○
57.1(*)	4	Vite	Screw	M 12 x 25 DIN 933	S		○
57.3(*)	4	Rondella	Washer	M 12 UNI1751/52 A	S		○
58	1	Cuscinetto	Ball bearing	3308 2RS		1004 0861	○
60	1	Linguetta	Key	8 x 7 x 30 DIN 6885A	K	1002 8331	○
63	1	Ghiera	Lock ring	30 x 49 x 4	S	1004 5696	○
66	1	Rondella	Washer	M 24 DIN 125 A	H	1000 1714	○
70	1	Ingrassatore	Ingrassatore	R 1/4"		1000 1662	○
						1000 8316	+P
70.2	1	Manicotto	Union	R 1/4" M/F	S		+P
70.3	1	Prolunga	Grease tube	1/4"	S		+P
75	1	Motore V=400-690(3ph)	A.C.motor V=400-690(3ph)	11 kW 2p B35 IP55		1004 2939	○
80	1	Piede motore	Motor base		S	1004 3159	○
80.1	1	Kit piede motore	Electric motor foot		S	1004 3182	○
83.1	1	Gancio di sollev.	Lifting hook		S	1004 3806	○
100	1	Kit piede pompa	Pump base kit		S	1004 5706	○
100.1	1	Piede pompa	Pump base	330 x 120 x 65	S	1004 5705	○
100.2	4	Vite	Screw	M 12 x 30 DIN 933	S	1000 1960	○
100.3	4	Dado	Nut	M 12 DIN934	S	1000 1422	○
100.4	4	Rondella	Washer	M 12 DIN 125A	S	1000 1699	○
( * )		Serie viterie	Set of screw			1003 9798	○
( ** )		Serie guarnizioni	Set of gaskets		N	1003 9797	○
+F ***		Kit flange	Kit flange	DN 50 PN 16	G	1004 2783	○
				2" ASA150	G	1004 2818	○
+P ***		Kit ingrassatore	Compl. Grease kit			1000 8316	○
+Z ***		Kit portine	Set of couver		GZ	1001 4124	○
+M ***		Kit manigiette	Set of wrench		OTS	1004 2794	○
***		Optional					

<b>Note:</b>		<b>Notes:</b>	
1) Completo di prigionieri (47, 48, 49, 50).		1) Complete with studs (47, 48, 49,50).	
2) Completo di viti (57).		2) Complete with screws (57).	
3) Completo di guarnizione (42).		3) Complete with gasket (42).	
4) Completo di supporto (06), piede (06.1), vite (06.2) e rondella		4) Complete with bearing housing (06), foot (06.1), screw (06.2) and	
5) Completo di dado, rondella e linguette (33, 60, 61, 66)		5) Complete with nut, washer and keys (33, 60, 61, 66)	
* Materiali di costruzione		* Construction materials	
E3	= Centellen VS 3820	E3	= Centellen VS 3820
G	= Ghisa	G	= Cast iron
GS	= Ghisa sferoidale	GS	= Ductile cast iron
H	= Acciaio inox AISI 304	H	= AISI 304 stainless steel
K	= Acciaio inox AISI 316	K	= AISI 316 stainless steel
N	= Nitrile	N	= Nitrile rubber
OTS	= Ottone	OTS	= Brass
S	= Acciaio	S	= Steel
Z	= Zinco	Z	= Zinc
Ordinare il materiale indicando sempre la quantità, la denominazione, il codice del pezzo, il tipo e il numero della pompa.		When ordering spares always indicate: quantity, part name and part number, type and serial number of pump.	