

Performance according to ISO 9906 - Annex A

Power data referred to:

Water [100%]; 277K; 1000kg/m³; 1.57mm²/s

Liquid temperature:

-10°C (14°F) to +110 °C (230°F) for heating pumps

-10°C (14°F) to +85 °C (185°F) for domestic hot water pumps



Pump data

Make	Lowara
Port to port (mm)	280
Electrical connection	Terminals
Specific EEI	<= 0,23
Nominal pressure	PN 6/10
Connection	Flanged / DN 50

Electrical data

Rated voltage	230 V
Frequency	50 / 60
Protection class	IP 44
Insulation class	F
Digital input	Contact load: 5V, 10 mA
Digital output	Vmax < 250 VAC / Imax < 2 A
Analog input	0-10 V / 4-20 mA
Leakage current	< 3.5 mA
Communication capabilities	Modbus RTU & BACnet MS/TP
Sound pressure level	<= 43 dB(A)

Materials

Bush Bearing	Carbon, resin impregnated	impeller	PPS
Thrust bearing	Aluminum oxide	Wear ring	Stainless steel
Bearing plate	Stainless steel	Rotor can	Stainless steel
Motor housing	Aluminum	Shaft	Stainless steel
O-rings	EPDM	Control box	Poly carbonate
Pump housing	Bronze		

Dimensions mm

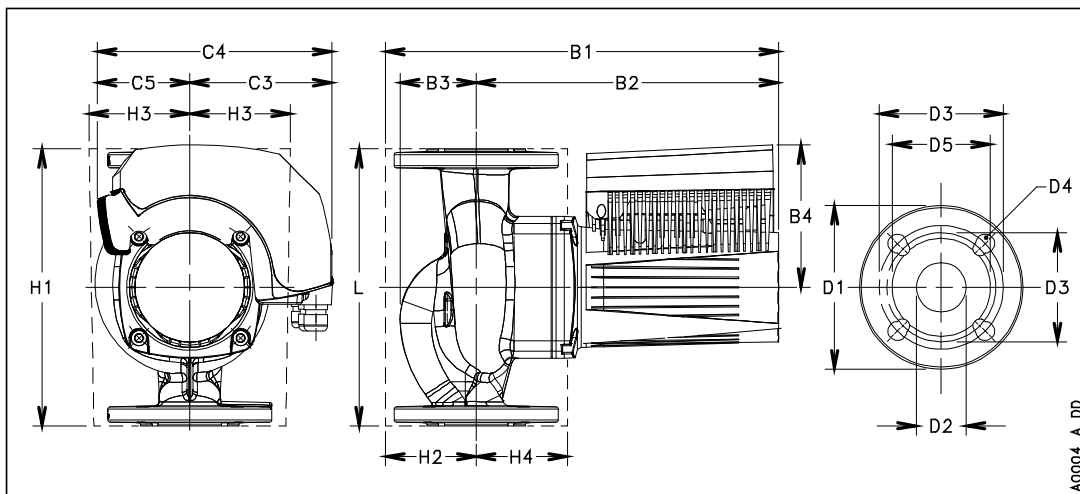

B1	368
B2	290
B3	78
B4	147
B5	60
C3	148
C4	230
C5	82
D1	165
D2	50
D3	110/125
D4	4 x 14/19
D5	100
Gross weight	21.9
H1	280
H2	94
H3	105
H4	95
L	280
Net weight	18