

ECN No.	DATE	DETAILS	REVISION
3464	20/02/2014	FIRST ISSUE	↑
*	*	*	*
*	*	*	*
*	*	*	*

STUART TURNER LTD HENLEY-ON-THAMES.

REVISION	DRG No.
1	41617

THIRD ANGLE PROJECTION

DIMENSIONS IN MILLIMETRES

MACHINING SYMBOLS TO BS 8888

REMOVE ALL BURRS AND SHARP EDGES

If drawing is to be used for constructional purposes please contact Stuart Turner Ltd and request a certified document

Stuart Turner Ltd reserves the right to amend specifications without notice.

PUMP	DIM A	DIM B
PH 35 TS	191	54
PH 45 TS	220	54

6 SLOTS 7mm WIDE

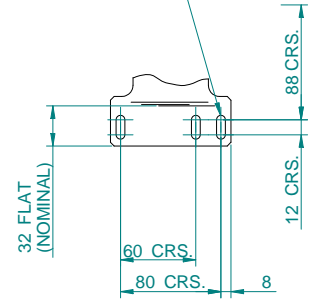

MOTOR FOOT DETAIL
SCRAP VIEW ON
ARROW X
(UNDERSIDE OF BASE)
SCALE 12

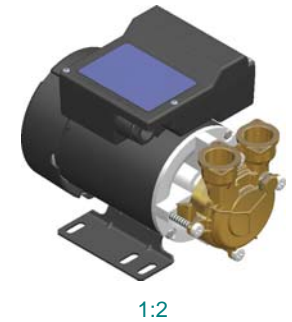
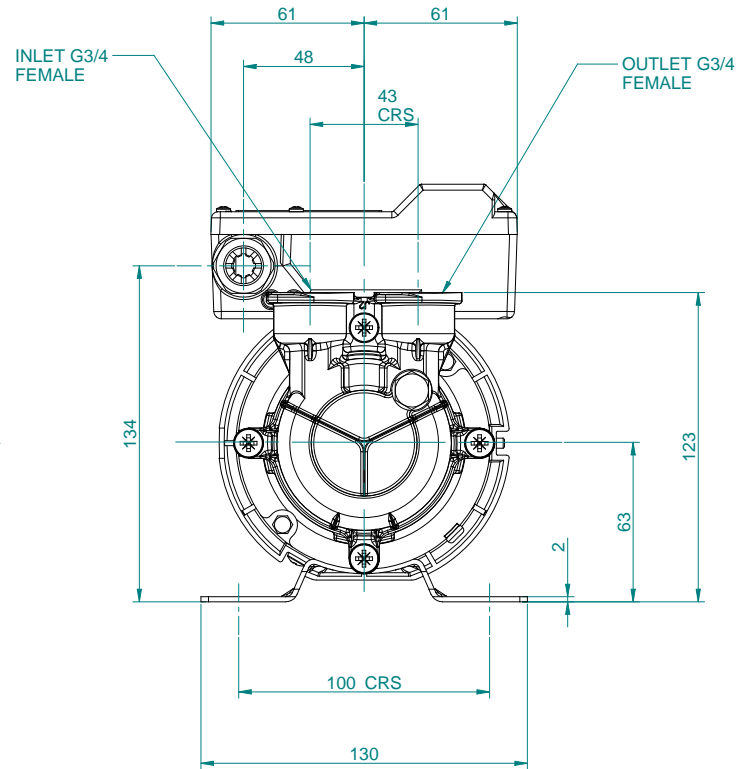
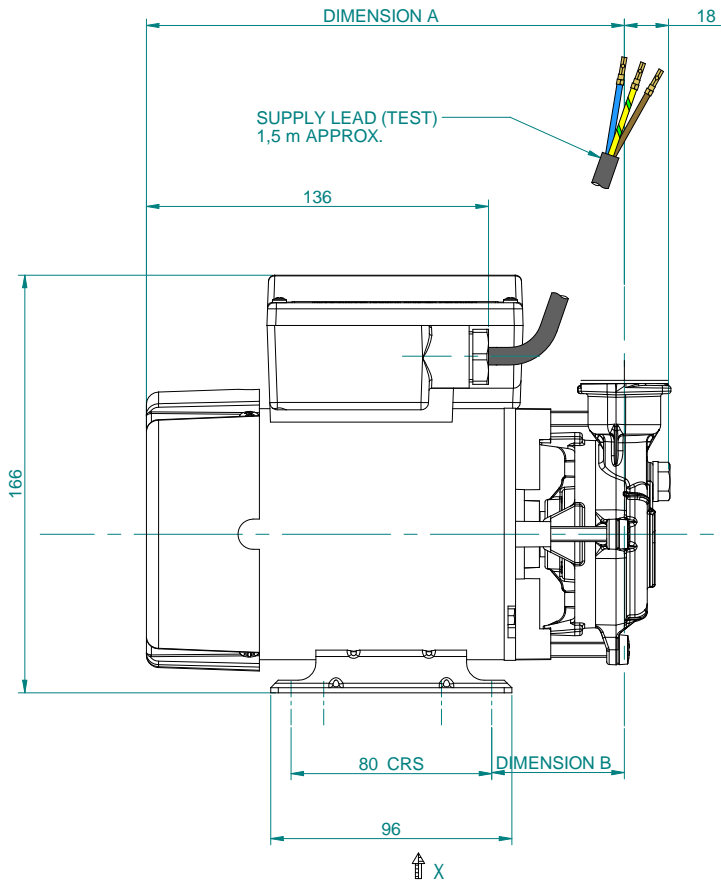

Stuart Turner Ltd own the copyright within this document. The document may be printed for personal use only. The document must not be altered, reproduced or utilized in any way without written permission from Stuart Turner Ltd, Henley-on-Thames, Oxon, UK.

DRAWN	AJW
CHECKED	
DATE	06/03/2014

OUTLINE ARRANGEMENT FOR PH TS PUMPS

SUPERSEDES	40790-2
ALL COMPONENTS SUPPLIED IN RELATION TO THIS DRAWING MUST BE IN FULL COMPLIANCE WITH THE RoHS DIRECTIVE (2002/95/EC)	

GENERAL LIMIT	± 2 mm
FILE	SOLIDEDGE FILES\DRAWING\PUMPS\CAI41617
MATL.	.

SCALE	1:1	A1
DRG.No.	41617	