

STUART TURNER LTD HENLEY-ON-THAMES.

THIRD ANGLE PROJECTION

DIMENSIONS IN MILLIMETRES

MODEL	DIM. 'A'	DIM. 'B'
MONSOON S15 bar TWIN	227	119
MONSOON S2.0 bar TWIN	227	119
MONSOON S3.0 bar TWIN	227	119
MONSOON S4.0 bar TWIN	262	154
MONSOON S4.5 bar TWIN	272	164

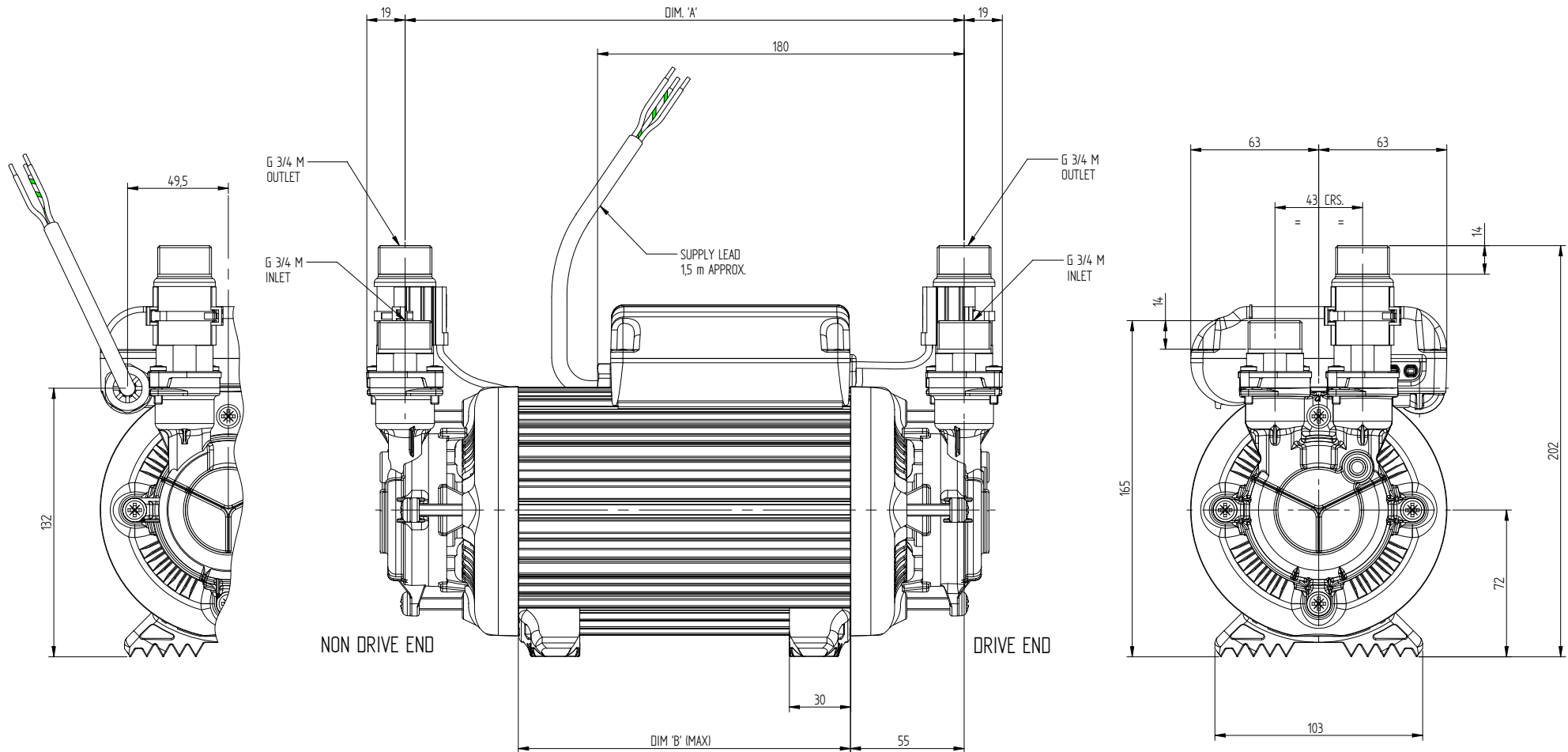

If drawing is to be used for constructional purposes please contact Stuart Turner Ltd and request a certified document.

Stuart Turner Ltd reserves the right to amend specifications without notice.

Stuart Turner Ltd own the copyright within this document. The document may be printed for personal use only. The document must not be altered, reproduced or utilized in any way without written permission from Stuart Turner Ltd, Henley-on-Thames, Oxon, UK.

GENERAL ARRANGEMENT OF A MONSOON STANDARD 1.5, 2.0, 3.0, 4.0 & 4.5 bar TWIN

W41191

DATE: 01/10/09