

# Diver 35 & 45 Submersible Pumps

The Diver 35 & 45 submersible pumps offer a solution to lifting clean fresh water only for high head (pressure) requirements.

Incorporating a floating switch to protect against running dry, these pumps are ideal for applications where pressure is needed, such as sprinklers or pumping up to storage tanks.

## Boostamatic

These options, with control module remotely located in a dry position, are ideal for irrigation or water supply applications where the pump can be located in a well or pond for instance.

All models carry a 12 month warranty period.

### Features

- Fully automated - no switch setting necessary.
- A built in 'no water' safety cut out.
- No pulsating when operating.

### Materials

Body	Polypropylene/stainless steel
Impeller	PPO
Motor casing	304 Stainless steel
Pump shaft	304 Stainless/ceramic
Seal	Nit/car/cer

### Operating Conditions

Max. liquid temp.	35°C
Min. liquid temp.	4°C
Max. immersion depth	10 m
Cable	H07RN-F3 15 m

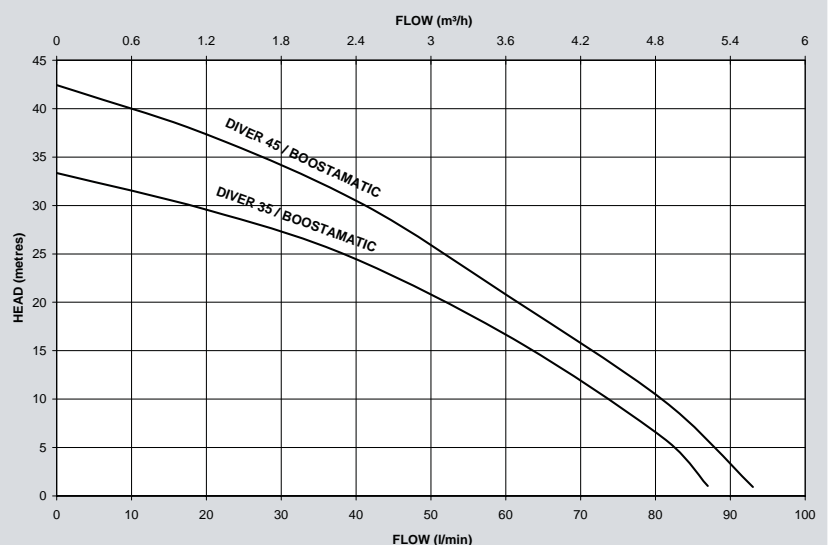

# Diver 35 & 45 Submersible Pumps

Model	Motor*	Nominal Watts	Watts full flow	Amps full load	Impeller	Seal	Carton dims. mm			Gross weight (packed) kg	Part no.
							L	x W	xH		
Diver 35	230/1/50	720	774	3.7	PPO	Nit/Car/Cer	180	240	405	9.0	46585
Diver 45	230/1/50	1000	1012	4.7	PPO	Nit/Car/Cer	180	240	405	9.6	46586
Diver 35 Boostamatic	230/1/50	720	774	3.7	PPO	Nit/Car/Cer	195	250	593	10.8	46611
Diver 45 Boostamatic	230/1/50	1000	1012	4.7	PPO	Nit/Car/Cer	195	250	593	11.3	46612

\*Built to IPX8, motors are designed for continuous running and feature thermal overload protection. A residual current device having a rated current not exceeding 30mA must be installed in the supply circuit.

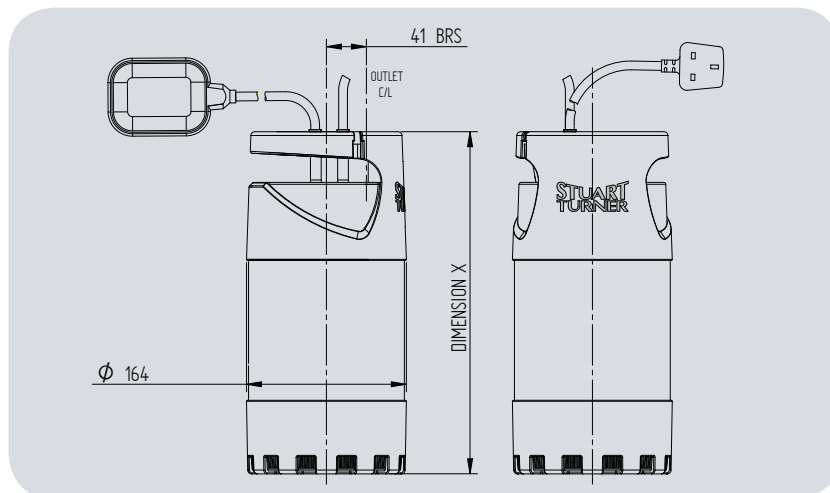

The Diver pumps are supplied complete with hose union, suitable for 25 mm (1") bore hose.

#### Pump Connection Sizes

Diver 35 & 45	G 1 Female
Control module	
Boostamatic models only	G 1 Male

Pump Description	Dim. X
Diver 35/ Boostamatic Diver 35	350
Diver 45/ Boostamatic Diver 45	387

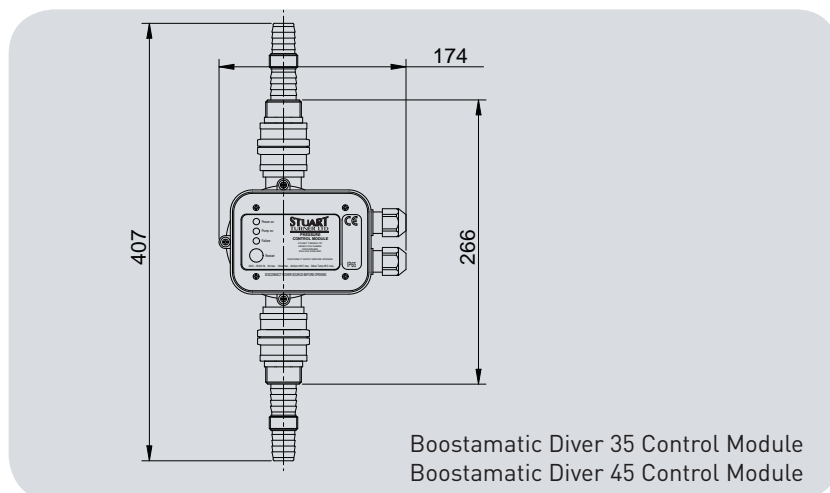

Boostamatic Diver 35 Control Module  
Boostamatic Diver 45 Control Module

All dimensions shown are in mm.

Stuart Turner Ltd  
Henley-on-Thames  
Oxfordshire RG9 2AD  
England

Telephone:  
+44 (0)1491 572655  
Fax:  
+44 (0)1491 573704

Email:  
pumps@stuart-turner.co.uk  
Web:  
www.stuart-turner.co.uk

**STUART  
TURNER**