

Installation, Operation & Maintenance Instructions

Please leave this instruction booklet with the owner as it contains important guarantee, maintenance and safety information



Read this manual carefully before commencing installation.

This manual covers the following products.

CH 4-30 FL
Pt. No. 46578

CH 4-40 FL
Pt. No. 46596

CH 4-50 FL
Pt. No. 46605

CH 4-60 FL
Pt. No. 46606

FOR POSITIVE HEAD APPLICATIONS ONLY



PRODUCT DESCRIPTION

Electric motor driven centrifugal pump complete with an automatic control system, consisting of flow switch, and electronic control.

APPLICATION

The Stuart CH FL range is designed for pressure boosting applications in vented stored, hot, cold or blended clean water systems, where under gravity, a flow is available of at least 1 l/min. If you wish to boost both hot and cold services, then CH Boostamatic models must be used, for further details contact 'PumpAssist'.

Inlet pressures to the pump and ambient temperatures must not exceed the values given in the technical specifications.



- **This pump set must not be used for any other application without the written consent of Stuart Turner Limited and in particular must not be connected directly to the mains water supply.**
- **This pump must not be connected directly to the mains water supply.**
- **This appliance can be used by children aged from 8 years and above and persons with reduced physical, sensory or mental capabilities or lack of experience and knowledge if they have been given supervision or instruction concerning use of the appliance in a safe way and understand the hazards involved. Children shall not play with the appliance. Cleaning and user maintenance shall not be made by children without supervision.**
- **Children should be supervised to ensure that they do not play with the appliance.**
- **This product should not be used for the supply of water to more than one dwelling (house, apartment, flat).**

Please read installation details carefully as they are intended to ensure this product provides long, trouble free service. Failure to install the unit in accordance with the installation instructions will lead to invalidation of the warranty.

STORAGE

If this product is not to be installed immediately on receipt, ensure that it is stored in a dry, frost and vibration free location in its original packaging.

Cont ...

CONTENTS	Page
Checklist	4
Important Facts - read before commencing installation	5
Location	6
Electrical Installation	10
Commissioning	12
Maintenance	13
Technical Specification	14
Trouble Shooting	15
Guarantee	17

CHECKLIST

IMPORTANT: With the pump removed from its packaging check for any damage prior to installation. If any damage is found contact Stuart Turner Ltd within 24 hours of receipt.

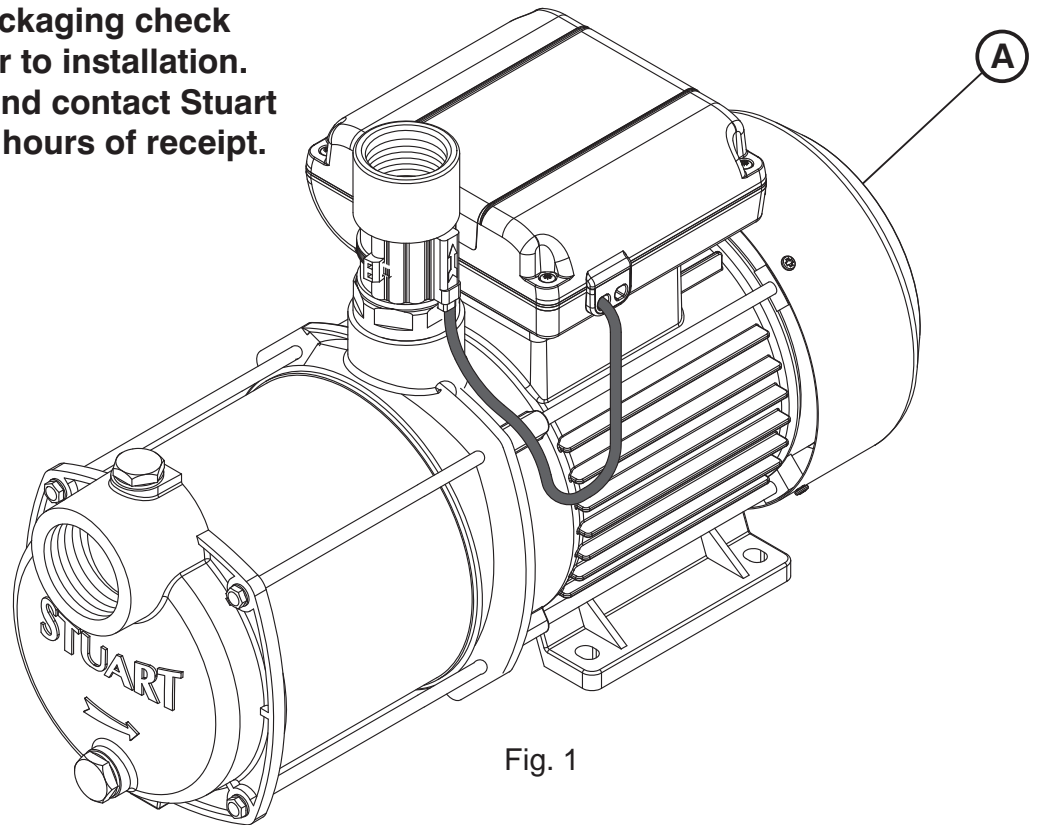

Fig. 1

Item	Description	Qty	Item	Description	Qty
(A)	Pump	1			

Your product may vary slightly from the picture above.

Cont ...

1 READ BEFORE COMMENCING PUMP INSTALLATION

A. Water storage capacity.

- 1.11 The water storage capacity must be sufficient to meet the flow rates required by the pumped equipment and any other water using fittings and appliances, which may be operated simultaneously.
- 1.12 Ensure the pump is primed as described in the priming section before starting, damage to the shaft seal will result otherwise. See Section 4 - Commissioning.

B. Water temperature

The water entering the pump must be controlled as follows:

- 1.13 The maximum allowable water temperature is 65 °C.
- 1.14 The minimum allowable water temperature is 4 °C.
- 1.15 **DO NOT** fit a pump if the hot water is heated via a method whereby the water temperature cannot be controlled, such as solar or solid fuel you must consult the PumpAssist team at Stuart Turner Ltd.

C. Pipework - General

- 1.16 **Secure pipework:** Ensure pipework to and from pump is independently supported & clipped to prevent forces being transferred to inlet and outlet branches of pump.
- 1.17 **Flux:** Solder joints must be completed and flux residues removed prior to pump installation (**flux damage will void any warranty**).
- 1.18 **Pipework design:** Care should be taken in the design of pipework runs to minimize the risk of air locks e.g. use drawn bends rather than 90° bends.



- 1.19 **DO NOT** introduce solder flux to flexible hoses, pumps or pump parts manufactured from plastic.

- 1.20 **DO NOT** allow contact with oil or cellulose based paints, paint thinners or strippers, acid based descalents or aggressive cleaning agents.



- 1.21 **DO NOT** install a non-return valve, or devices which contain non-return valves, in the suction (inlet) pipework to the pump. The pump must be free to vent to the supply tank at all times.

- 1.22 **DO NOT** connect this pump to the mains water supply.

D. Plumbing & Electrical Installation Regulations

- 1.23 The plumbing installation must comply with “The Water Supply (Water Fittings) Regulations 1999” and “BS 6700” building regulations.
- 1.24 The plumbing installation must be installed by a qualified person.
- 1.25 The electrical installation must be carried out in accordance with the current national electrical regulations.
- 1.26 The electrical installation must be installed by a qualified person.

2 LOCATION - GENERAL



- 2.11 **Access:** For emergencies and maintenance the pump must be easily accessible.
- 2.12 **Protection:** The pump must be located in a dry position, frost free and protected from freezing, particularly when installed in a loft (not recommended).
- 2.13 **Ventilation:** Ensure an adequate air flow to cool the pump. Separate the pump from other appliances that generate heat. An 80 mm (3 ") air gap must be maintained around the pump.
- 2.14 **Safety:** The motor casing can become very hot under normal operating conditions. Care must be taken to ensure it cannot be touched during operation.
- 2.15 **Water retention:** Site the pump in a location where in the unlikely event of a water leak, any spillage is contained or routed to avoid electrics or areas sensitive to water damage.
- 2.16 **Static inlet pressure:** Before deciding where to locate the unit check to ensure the static inlet head between pump and cold water level (Figs. 2 & 3) is at least 1 metre and does not exceed the max inlet head of 10 metres.
- 2.17 **Pump position:** The pump must be positioned on its anti-vibration mounting feet and as close to the water source as possible.
- 2.18 **Ambient temperature:** The pump must be sited in a location where the maximum ambient temperature does not exceed 50 °C.
- 2.19 **Pipework:** For optimum performance pipework use 28 mm dia., 22 mm can be used but will result in reduced pump performance.
Pipework should only reduce to 15 mm when entering terminal fitting.
- 2.20 **Static outlet pressure:** The static outlet head is indicated in Figs. 2 & 3.
- 2.21 **Direction of flow:** Ensure the water flow is in the direction of the arrow marked on the flow switch reed clamp (vertically upwards).
- 2.22 **Isolating valves:** Separate isolating valves (non restrictive) must be fitted to allow easy pump service.
- 2.23 **Inline strainer:** When pump is to be installed in areas where there is risk of debris or scale build up within the system, you **MUST** ensure the inlet pipework is fitted with an inline strainer.
- 2.24 **Preferred pump location:** The preferred pump location is below the water supply connection that feeds the pump. The pump location is also dependent on limitations of the static inlet and outlet heads of the installation. For guidance on limitations and recommended location, consult the following relevant section for hot or cold water installation.

2 LOCATION - COLD WATER INSTALLATION

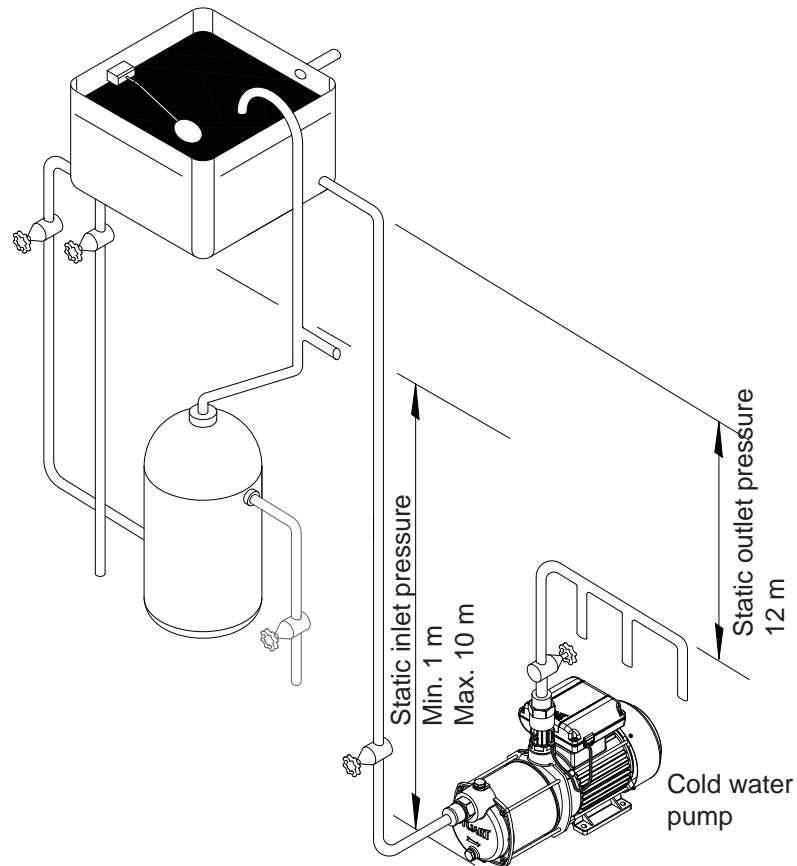

Fig. 2

2.25 **The cold water supply:** The supply **must be AIR FREE** and have a **DEDICATED CONNECTION to the tank** which should be via a tank connector, positioned at a slightly lower level (25 mm minimum) than the feed pipe to the hot water cylinder.

2 LOCATION - HOT WATER INSTALLATION

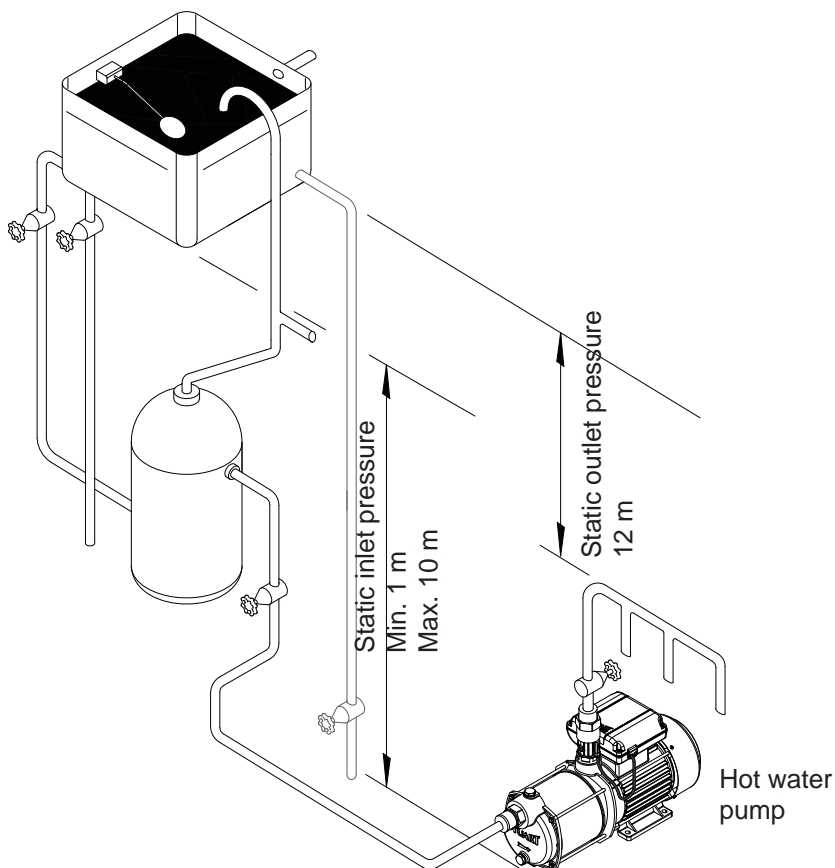

Fig. 3

Hot water connection:

2.26 **Hot water cylinder or storage tank:** When a hot water cylinder or storage tank is used, ensure the pipework size from the cold water storage to the hot water storage is of adequate size and a minimum of 28 mm.

2.27 **Hot water supply:** The pump **must be** supplied with a **dedicated feed** direct from the hot water cylinder or storage tank which should be via a secondary dedicated tapping (see Fig. 4).

Do not connect to the mains.

2.28 **Location:** The pump must, for optimum performance, be sited as close as possible to and never more than 4 metres from the HOT WATER cylinder. The pump should always be sited BELOW the HOT WATER take-off from the cylinder.

Fig. 4

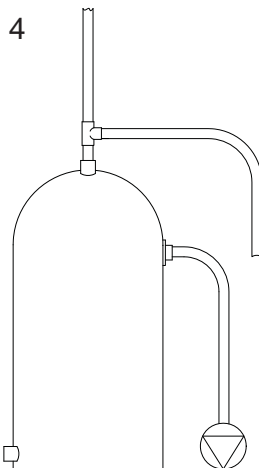

Factory installed secondary tapping with 28 mm.

Cont ...

2.29 Non-Preferred Pump Location: The pump must be located with at least 1 metre flooded suction at all times.

If it is not possible to locate the pump in the preferred area due to site limitations and it is necessary to position the unit in the loft, or in a position above the secondary tapping that feeds the pump, then there is an increased risk of air locks. This risk must be eliminated.

The following method will help to overcome the problem:

In this application only use an Essex or side entry flange, then fit a “U” bend or downward loop in the supply pipe to the pump of 350 mm depth before rising to the pump should ensure the cylinder vents its air up the expansion pipe, not up the pump feed (Fig. 5).

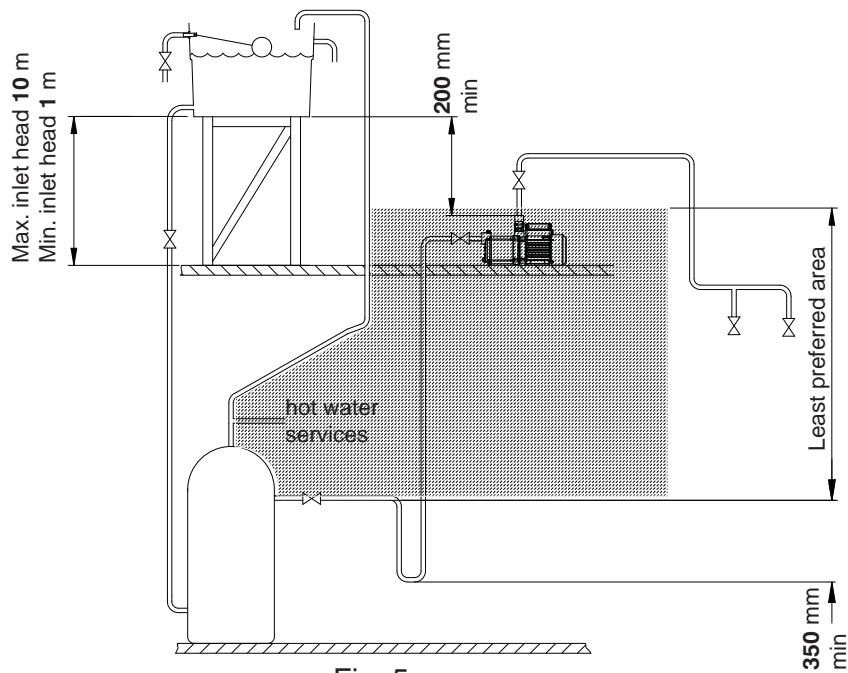

Fig. 5

3 ELECTRICAL INSTALLATION / EARTHING



- 3.11 **Regulations:** The electrical installation must be carried out in accordance with the current national electrical regulations and installed by a qualified person.
- 3.12 **Safety:** In the interests of electrical safety a 30 mA residual current device (**R.C.D. not supplied**) should be installed in the supply circuit. This may be part of a consumer unit or a separate unit.
- 3.13 Before starting work on the electrical supply ensure power supply is isolated.
- 3.14 **DO NOT** allow the supply cord to contact hot surfaces, including the motor shell, pump body or pipework. The cord should be safely routed and secured by cable clips.

- 3.15 **Adjacent pipes:** Adjacent suction and delivery pipes should be fitted with earthing clamps to BS 951 in accordance with current regulations (Fig.6).

Diagram of earth continuity connections

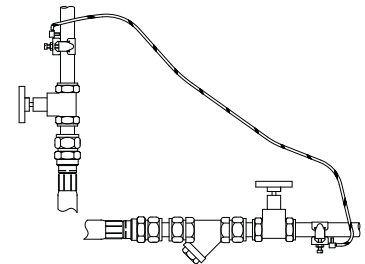

Fig. 6

- 3.16 **Earthing:** This appliance must be earthed via the supply cord, which must be correctly connected to the earth point located in the terminal box.
- 3.17 **Pipework:** Copper or metallic pipework must have supplementary earth bonding where the continuity has been broken by flexible hoses or plastic components (not supplied).
- 3.18 **Additional earthing:** Certain installations may require additional earthing arrangements such as equipotential bonding. Reference should be made to the relevant regulations concerning this subject to ensure compliance.
- 3.19 **Connections:** The pump must be permanently connected to the fixed wiring of the mains supply using the factory fitted supply cord, via a double pole switched fused spur off the ring main and **NOT** connected to the boiler or the immersion heater circuits.
- 3.20 **Wiring of connection unit:**



WARNING: This appliance must be earthed.

The wires in the mains lead are coloured in accordance with the following code:

Green and Yellow: Earth Blue: Neutral Brown: Live

As the colours of the wires in the mains lead of this appliance may not correspond with the coloured markings identifying the terminals in your connection unit proceed as follows:

The wire which is coloured green and yellow must be connected to the terminal in the connection unit which is marked with the letter E or by the earth symbol:  or coloured green or green and yellow.

The wire which is coloured blue must be connected to the terminal which is marked with the letter N or coloured black.

The wire which is coloured brown must be connected to the terminal which is marked with the letter L or coloured red.

3.21 Wiring Diagram:

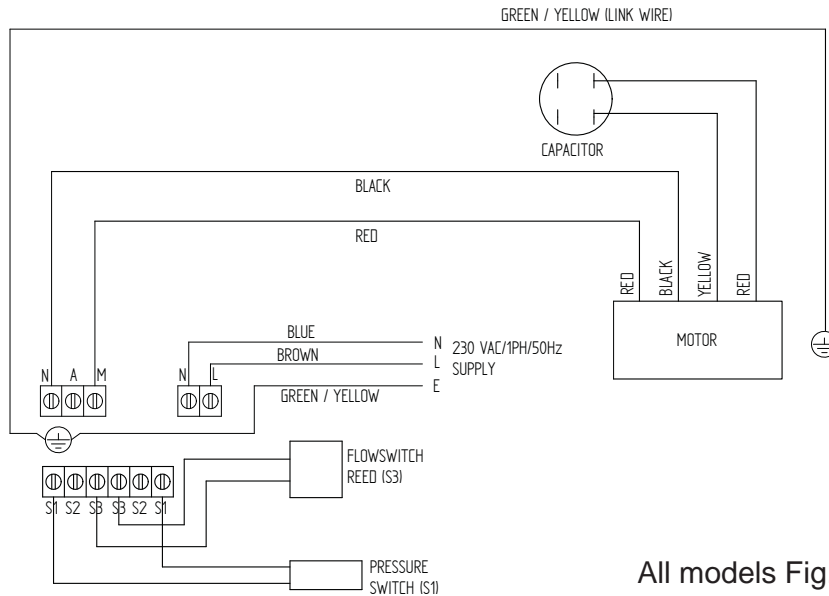

3.22 **Fuses:** The following fuse size should be used with the appropriate pump:

Model	Fuse Size (AMPS)
All Models	13

3.23 Supply Cord Replacement:



The supply cord and internal wiring within the terminal box are routed and secured to ensure compliance with the electrical standard EN 60335-1. It is essential that prior to any disturbance of this internal wiring, all cable routing and securing details are carefully noted to ensure re-assembly to the same factory pattern is always maintained.

If the supply cord is to be changed or is damaged, it must be replaced with a special cord assembly available from Stuart Turner or one of their approved repairers.

On disassembly note the cord retention and routing system. Re-assemble to the same pattern.

For information on cable connection consult the wiring diagram and cable gland fitting instructions.

3.24 Cable Gland Fitting Instructions:

To enable correct assembly of the cable gland the 'O'-ring (Fig. 8 item 1) must be placed over the cable before the clamping insert (Fig. 8 item 2) can be tightened.

Note: Cable diameter range:- 6.5 mm to 9.5 mm.

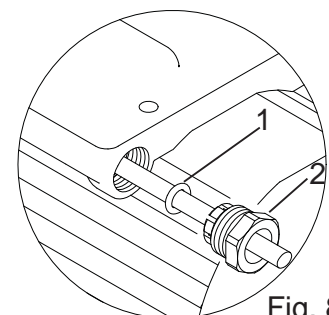

Fig. 8

3.25 Supply Cord Extension:

The pumps are fitted with a supply cord to the following specification:-

All models HO5VV-F3 G 0.75 mm² - 6 Amp rated cable.

If the supply cord is to be extended, a cord of the same specification should be used. Any connections or junction boxes used should be specifically suited for the application and installed in accordance with the manufacturers instructions.

4 COMMISSIONING / SYSTEM FLUSHING/ PRIMING / STARTING



4.11 **System Flushing:** The pipework system should be flushed out prior to the pump being connected to ensure any contaminants/ chemical residues and foreign bodies are removed from elsewhere in the system.

4.12 **Water Supply:** Always ensure that water storage capacity is adequate to meet the demand. Ensure the pump chamber is full of water before starting the pump. Failure to do this could result in seal damage. To ensure dry running does not occur the pump must be primed as described in priming section below.
Do not run pump dry.

4.13 **Priming:**



Never operate pump with inlet and/or outlet isolating valves in the closed position. Damage will occur!

The pump must be primed (filled with water) before starting.
Turn on the service valves and vent/prime pump head.

- (a) Loosen priming plug and allow an even flow of water this may take a few seconds.
- (b) Re-seal draining plug, nipping tight. The pump is now ready to start.

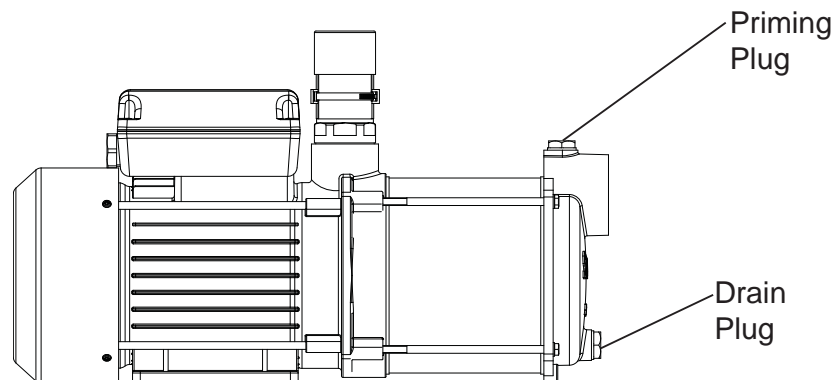

All models Fig. 9

4.14 **Starting:**

- a) Switch on power and open terminal fitting.
- b) Open and close all outlets in turn associated with the pump, (including w/c systems) allowing water to flow from each outlet until all air is purged. As each outlet is opened and closed, the pump will start and stop respectively.
- c) Any tap or control valve within the system when opened and closed will now turn the pump on/off. Providing this is the case the system is now operating correctly.
- d) Carefully check pump and pipework for leaks whilst pump running and stationary before leaving the installation unattended.

4.15 **For Further Technical Support:** Phone the Stuart Turner PumpAssist team on 0844 98 000 97. Our staff are trained to help and advise you over the phone.

Cont ...

5 MAINTENANCE

5.11 Cleaners, Disinfectants and Descalents:



Acid based descalents and aggressive cleaning agents must not come into contact with the pump. The pump must be removed from the system prior to the use of these products. The system should be flushed to remove all chemicals before the pump is re-connected. If in any doubt as to the suitability of the chemical solutions, please contact our PumpAssist helpline on 0844 98 000 97.

6 TECHNICAL SPECIFICATION

Model		CH 4-30 FL	CH 4-40 FL	CH 4-50 FL	CH 4-60 FL
Electrical	Power supply Volts/phase frequency	230/1/50	230/1/50	230/1/50	230/1/50
	Enclosure	IPX5	IPX5	IPX5	IPX5
	Type of motor	Induction	Induction	Induction	Induction
	Power consumption	805 Watts	1210 Watts	1640 Watts	1980 Watts
	Full load current	3.6 Amps	5.4 Amps	7.3 Amps	8.8 Amps
	Rating	Continuous (S1)	Continuous (S1)	Continuous (S1)	Continuous (S1)
	Max. No Starts per hour	60	60	60	60
Mechanical	Min inlet head	1 metres	1 metres	1 metres	1 metres
	Max inlet head	10 metres	10 metres	10 metres	10 metres
	Max head (closed valve)	25 metres	36 metres	50 metres	61 metres
	Max working pressure*	600 kPa (6.0 bar)	900 kPa (9.0 bar)	900 kPa (9.0 bar)	900 kPa (9.0 bar)
	Max ambient air temperature	50 °C	50 °C	50 °C	50 °C
	Max water temperature**	65 °C	65 °C	65 °C	65 °C
	Min water temperature	4 °C	4 °C	4 °C	4 °C
Cut in flow	1 l/min (approx)	1 l/min (approx)	1 l/min (approx)	1 l/min (approx)	
Pump Dimensions	Length (max)	360 mm	384 mm	431 mm	456 mm
	Width (max)	155 mm	155 mm	187 mm	187 mm
	Height (excluding flexible hoses)	228 mm	228 mm	247 mm	247 mm
	Gross Weight (including accessories)	10 Kg	12 Kg	15.5 Kg	18.0 Kg
	Pump Connections: Inlet	G 1¼ Female	G 1¼ Female	G 1¼ Female	G 1¼ Female
	Outlet	G 1 Female	G 1 Female	G 1 Female	G 1 Female
Materials	Body	Brass/St St	Brass/St St	Brass/St St	Brass/St St
	Shaft	Stainless Steel	Stainless Steel	Stainless Steel	Stainless Steel
	Mechanical Seal	EPDM/car/cer	EPDM/car/cer	EPDM/car/cer	EPDM/car/cer
	Pump Parts	GEPP0	GEPP0	GEPP0	GEPP0

Stuart Turner reserve the right to amend the specification in line with its policy of continuous development of its products.

*Note: Max working pressure is the maximum pressure that can be applied to the pump internal casing under any installation conditions.

**Note: In normal circumstances the temperature of stored water should never exceed 65 °C. A stored water temperature of 60°C is considered sufficient to meet all normal requirements and will minimise deposition of scale in hard water areas.

6.11 **Noise:** The equivalent continuous A-weighted sound pressure level at a distance of 1 metre from the pump does not exceed 70 dB(A).

Cont ...

7 TROUBLE SHOOTING GUIDE

Symptoms	Probable Cause	Recommended Action
Pump will not start.	<p>Electrical supply.</p> <p>Pump Jammed.</p> <p>Recommended static inlet/outlet heads exceeded.</p> <p>No flow.</p> <p>Internal motor thermotrip activated.</p>	<p>Check power supply. Check fuse (see fuse section). Check circuit breaker is set. Check wiring connections.</p> <p>If motor 'Buzzes' switch off power and contact Stuart Turner.</p> <p>Re-position pump (see pump location section).</p> <p>Insufficient gravity flow to start the pump (must be at least 1 l/min).</p> <p>Wait for thermotrip to auto-reset and check that duty point and run time is within specification (see technical specification).</p>
Reduced/intermittent flow.	<p>Incorrect or no anti-aeration flange fitted</p> <p>Incorrect pipe sizes.</p> <p>Blocked inlet filters.</p> <p>Air in system.</p> <p>Hot water temperature set too high.</p> <p>Blocked shower head spray plate</p>	<p>Check that the installation complies with installation instructions.</p> <p>Check for correct pipe sizing, see Page 6 - Section 2.19.</p> <p>Clean inline strainer.</p> <p>Run system on full hot for several minutes. Check that vents are fitted as detailed in instructions.</p> <p>Reduce cylinder stat setting to 60 °C max.</p> <p>Clean in accordance with manufacturers instructions.</p>
No hot water.	<p>Air locked water feed.</p> <p>Heat source not operating.</p> <p>All hot water has been used.</p> <p>Faulty thermostatic mixer valve.</p>	<p>Vent hot water pump of air. Check cold feed to hot water cylinder. Check water level in cold water tank and that all stopcocks and isolating valves are open.</p> <p>Check boiler is switched 'on'. Check cylinder thermostat. Check immersion heater. Check cylinder contains hot water.</p> <p>Check tank volume is adequate.</p> <p>Consult makers instructions.</p>
Pump runs on with outlets closed.	<p>Leak in system.</p> <p>Damaged reed switch, P.C.B.</p> <p>Jammed flow switch.</p>	<p>Check tap washers, w/c valve washers, pipe joints.</p> <p>If pump continues to run, this indicates a closed circuit in either the flow switch reed, or P.C.B. in the terminal box. Contact Stuart Turner.</p> <p>Remove outlet hoses and check that flow switch sits in lowest position. Check float for free movement.</p>
Flexible hose leaks	<p>Not fitted correctly.</p> <p>Damaged 'O'-rings.</p>	<p>Check that the hose is pushed firmly onto the pump inlet/outlet connections and pipework.</p> <p>Check copper pipe ends are cleanly cut and deburred.</p>

Cont ...

7.11 Flow Switch Circuit Test:

1. First confirm visually that the flow switch reed clamp have not been dislodged during handling or installation. The clamp must be fully located within the flow switch body groove as shown.
2. To carry out the following test you will need to obtain a magnet, a typical fridge magnet is suitable.
3. Ensure the power supply is switched on.
4. Position the magnet directly in front of the reed clamp as shown. If pump does not start, then slowly move the magnet up and down to a position that exceeds the extent of the reed clamp. The pump should instantaneously start at some point during this extent of movement. If this does not happen, this indicates a possible fault with the reed switch or the P.C.B which is located within the terminal box. These should be checked electrically. Consult Stuart Turner for further instructions.

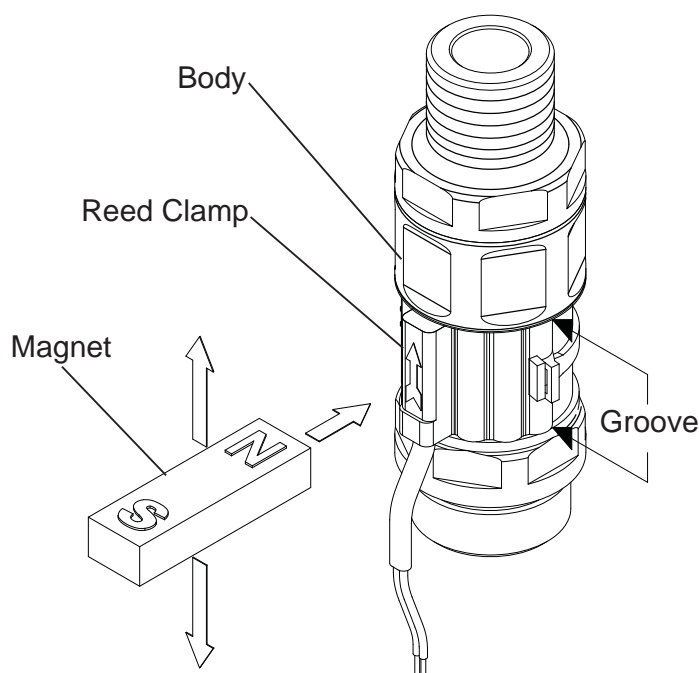

Fig. 10

7.12 Environment Protection: Your appliance contains valuable materials which can be recovered or recycled.

At the end of the products' useful life, please leave it at an appropriate local civic waste collection point.

8 YOUR 1 YEAR GUARANTEE

Stuart Pumps are guaranteed by Stuart Turner Limited to be free from defects in materials or workmanship and the guarantee period starts from the date of purchase or date of manufacture. Within the guarantee period we will repair, free of charge, any defects in the pump resulting from faults in material or workmanship, repairing, exchanging parts or exchanging the whole unit as we may reasonably decide.

Not covered by this guarantee: Damage arising from incorrect installation, improper use, unauthorised repair, normal wear and tear and defects which have a negligible effect on the value or operation of the pump.

Reasonable evidence must be supplied that the pump has been purchased within the applicable guarantee period prior to the date of claim (such as proof of purchase or the pump serial number).

This guarantee is in addition to your statutory rights as a consumer. If you are in any doubt as to these rights, please contact your local Trading Standards Department or Citizen's Advice Bureau.

In the event of a claim please telephone Stuart Turner Limited on 0844 980 0097 before taking any further action. If you have any doubt about removing a pump, please consult a professional.

Proof of purchase should accompany the returned pump to avoid delay in investigation and dealing with your claim.

Please record here for your records.

TYPE NO.	SERIAL NO.	DATE PURCHASED

NOTES

NOTES



DECLARATION OF CONFORMITY

2006/42/EC

BS EN ISO 12100-1, BS EN ISO 12100-2, BS EN 809

2006/95/EC

BS EN 60335-1, BS EN 60335-2-41

2004/108/EC

BS EN 55014-1, BS EN 55014-2, BS EN 55022, BS EN 61000-3-2, BS EN 61000-3-3,
BS EN 61000-4-2, BS EN 61000-4-3, BS EN 61000-4-4, BS EN 61000-4-5, BS EN 61000-4-6,
BS EN 61000-4-11

1999/519/EC

BS EN 62233

2011/65/EU

IT IS HEREBY CERTIFIED THAT THE STUART ELECTRIC MOTOR DRIVEN PUMP AS SERIAL NUMBER BELOW, COMPLIES WITH THE ESSENTIAL REQUIREMENTS OF THE ABOVE E.E.C. DIRECTIVES.

(_____)

RESPONSIBLE PERSON
AND MANUFACTURER

STUART TURNER LIMITED
HENLEY-ON-THAMES, OXFORDSHIRE
RG9 2AD ENGLAND.

Signed.....  Business Development Director

Stuart Turner are an approved company to BS EN ISO 9001:2000



Stuart Turner Ltd, Henley-on-Thames, Oxfordshire RG9 2AD ENGLAND

Tel: +44 (0) 1491 572655, Fax: +44 (0) 1491 573704

info@stpumps.co.uk www.stuart-turner.co.uk

V.A.T. REG. No. 199 0987 92. Registered in England No. 88368. Registered Office: Market Place, Henley-on-Thames