



ITT

Lowara

**DOC - DIWA - DOMO
DOMO GRI - DN - DL
Series**

**Drainage and Sewage
Electric Pumps**

50 Hz



Engineered for life



ITT

Lowara

DOC - DIWA - DOMO - DOMO GRI - DN - DL SERIES HYDRAULIC PERFORMANCE RANGE AT 50 Hz

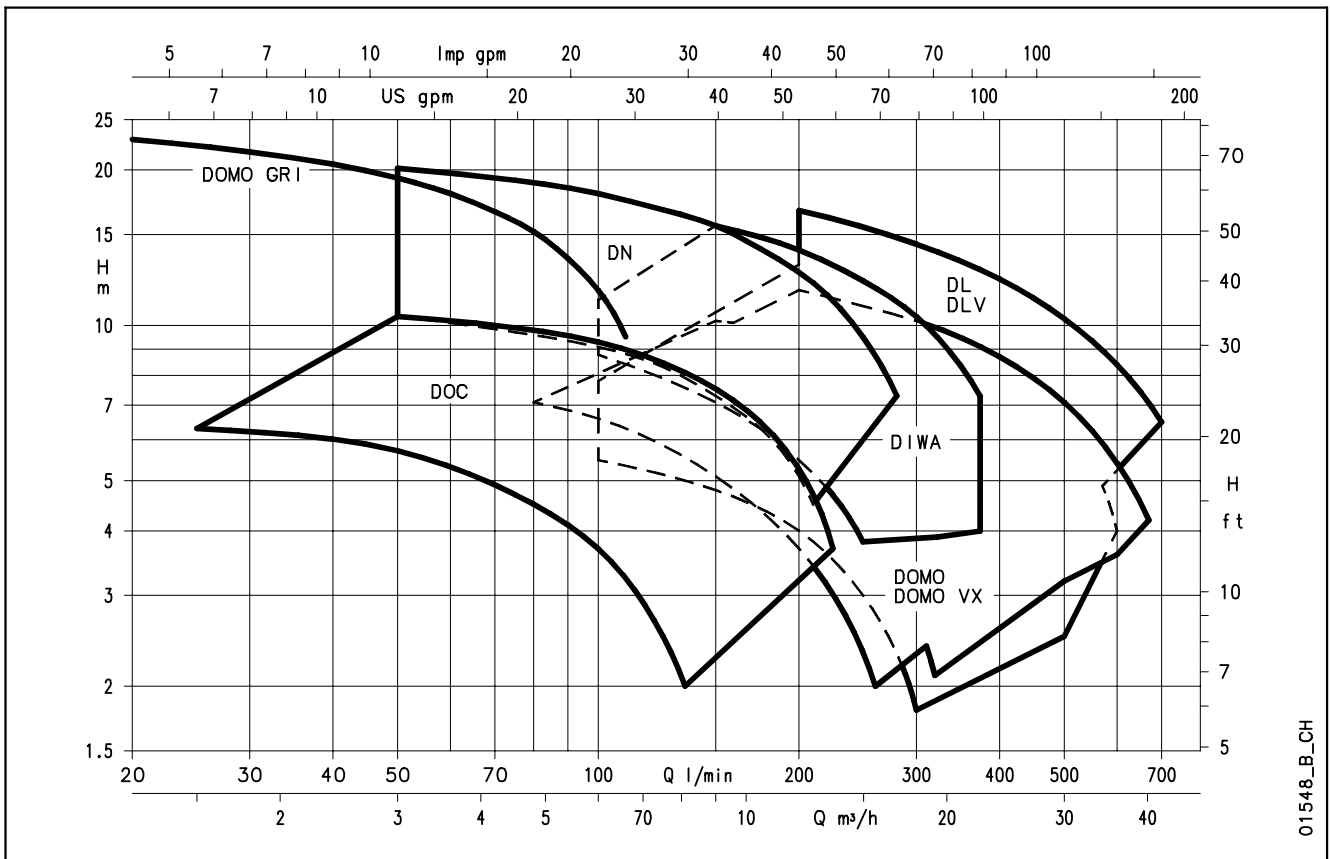



CONTENTS

DOC Series Specifications	5
DOC Series List of models and Table of Materials	7
DOC Series Operating Characteristics at 50 Hz	8
DOC Series Dimensions and Weights	9
DIWA Series Specifications	11
DIWA Series List of models and Table of Materials	13
DIWA Series Mechanical seal	14
DIWA Series Operating Characteristics at 50 Hz	15
DIWA Series Dimensions and Weights	16
DOMO Series Specifications	19
DOMO GRI Series Specifications	20
DOMO Series List of models and Table of Materials	22
DOMO GRI Series List of models and Table of Materials	23
DOMO - DOMO GRI Series Mechanical seal	24
DOMO Series Operating Characteristics at 50 Hz	25
DOMO GRI Series Operating Characteristics at 50 Hz	27



CONTENTS

DOMO Series Dimensions and Weights	28
DOMO GRI Series Dimensions and Weights	30
DN Series Specifications	31
DN Series List of models and Table of Materials	33
DN Series Mechanical seal	34
DN Series Operating Characteristics at 50 Hz	35
DN Series Dimensions and Weights	36
DL Series Specifications	37
DL Series List of models and Table of Materials	39
DL Series Mechanical seal	41
DL Series Operating Characteristics at 50 Hz	43
DL Series Dimensions and Weights	45
Technical Appendix	47



ITT

Lowara

Submersible Electric Pumps for clean and dirty water

DOC pumps are versatile, corrosion-resistant and compact. Three basic versions are available with 0,25 to 0,55 kW power. A DOC 7VX version with Vortex impeller is available.

DOC Series



APPLICATIONS

- Emptying of residential sump pits, rainwater tanks or laundry drainage.
- Garden and lawn irrigation, with suction from rainwater tanks.
- Emergency draining of flooded basements and garages.
- Transfer of water from tanks, cisterns and swimming pools.

SPECIFICATIONS

- **Maximum liquid temperature:** 40°C with partially submerged pump.
- **Dry motor.**
- Maximum immersion depth: 5 m.
- **Class B insulation.**
- The **DOC 3** pump has a delivery of **135 l/min**, head up to **7 m**, and passes **suspended solids up to 10 mm** in diameter. Only available in single-phase version.
- The **DOC 7** pump has a delivery of **225 l/min**, head up to **11 m**, and passes **suspended solids up to 10 mm** in diameter.

- The **DOC 7VX** pump has a delivery of **175 l/min**, head up to **7 m**, and can handle liquids with **suspended solids up to 20 mm** in diameter.
- A **“shallow-suction device”**, that can be mounted on both the DOC3 and DOC7 models, is available on request. It ensures complete drainage of flooded floors (to 3 mm from floor).
- **Versions:**
 - Single-phase: 220-240 V, 50 Hz
2 poles.
 - Three-phase: 220-240 V, 50 Hz
380-415 V, 50 Hz
2 poles.
- 60 Hz and without floats (SG) models are available on request or tube float switch.
- **The single-phase versions** features:
 - Pre-assembled float** for automatic pump operation (version without float available on request).
 - Built-in capacitor.**
 - Thermal overload protection** to stop pump supply in case of overheating.

LAB-LIP SEAL SYSTEM

- The electric motor is protected by **three lip seals**. An **impeller counterblade** system keeps solid particles away from the seal unit to prevent damage to the lip seals and ensure their long-lasting efficiency. A double **Labyrinth** and a **V-ring** on the shaft have also been provided.

DOC SERIES IDENTIFICATION CODE

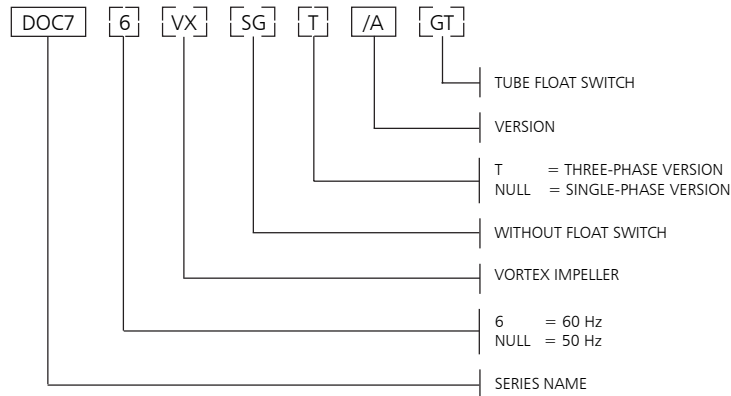

EXAMPLE : DOC 7VX/A
 DOC 7 Series Electric pump, 50 Hz version,
 Vortex impeller, single-phase, /A version.

SINGLE-PHASE RATING PLATE

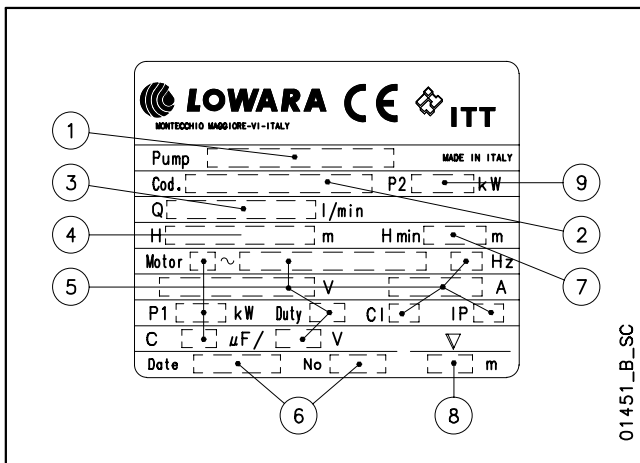

LEGEND

- 1 - Electric pump type
- 2 - Code
- 3 - Delivery range
- 4 - Head range
- 5 - Motor type
- 6 - Date of manufacture and serial number
- 7 - Minimum head
- 8 - Maximum immersion depth
- 9 - Rated output

THREE-PHASE RATING PLATE

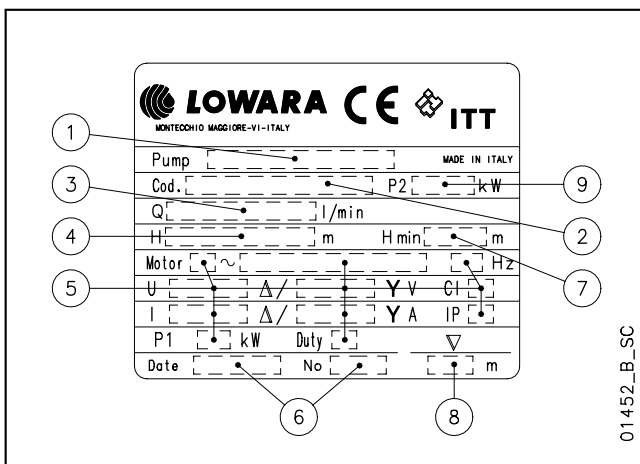



DOC SERIES LIST OF MODELS AND TABLE OF MATERIALS

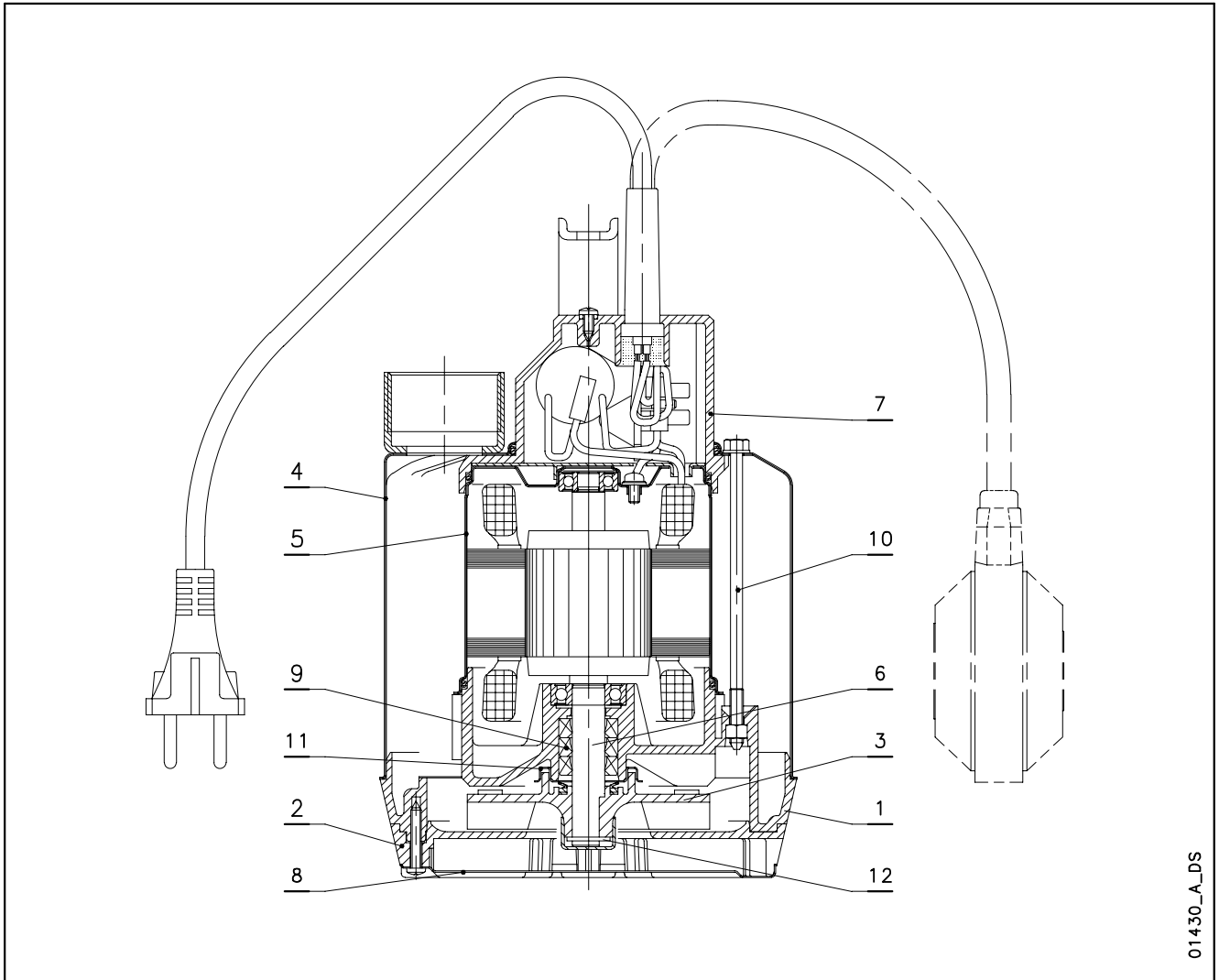

01430_A_DS

REF. N.	NAME	MATERIAL	REFERENCE STANDARDS	
			EUROPE	USA
1	Pump body	NORYL GFN 2V		
2	Suction strainer	NORYL GFN 2V		
3	Impeller	Technopolymer		
4	External case	Stainless steel	EN 10088-1-X5CrNi18-10 (1.4301)	AISI 304
5	Internal motor casing	Stainless steel	EN 10088-1-X5CrNi18-10 (1.4301)	AISI 304
6	Shaft	Stainless steel	EN 10088-1-X12CrS13 (1.4005)	AISI 416
7	Head	NORYL GFN 2V		
8	Lower cover	Stainless steel	EN 10088-1-X5CrNi18-10 (1.4301)	AISI 304
9	Elastomers	NBR		
10	Tie-rod and screws	Stainless steel	EN 10088-1-X5CrNi18-10 (1.4301)	AISI 304
11	Double wear ring	Stainless steel	EN 10088-1-X5CrNi18-10 (1.4301)	AISI 304
12	Impeller fixing ring	Stainless steel	EN 10088-1-X5CrNi18-10 (1.4301)	AISI 304



ITT

Lowara

DOC SERIES OPERATING CHARACTERISTICS AT 50 Hz

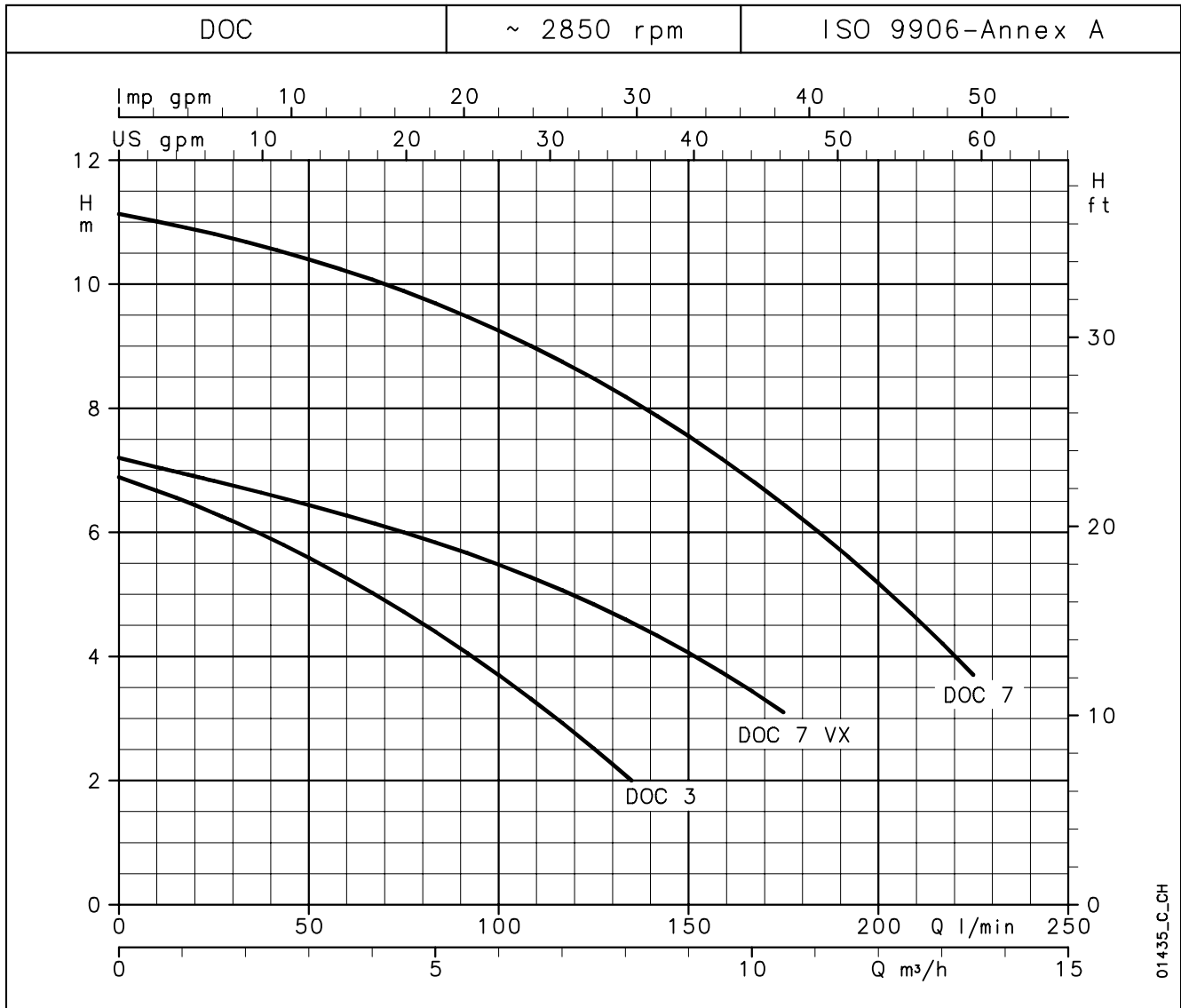

HYDRAULIC PERFORMANCE TABLE

PUMP TYPE	RATED POWER		Q = DELIVERY												
			l/min	0	25	50	75	100	125	135	175	225			
			m ³ /h	0	1,5	3	4,5	6	7,5	8,1	10,5	13,5			
		H = TOTAL HEAD METRES COLUMN OF WATER													
	kW	HP													
DOC3	0,25	0,33	6,9	6,3	5,6	4,7	3,7	2,5	2,0						
DOC7(T)	0,55	0,75	11,1	10,8	10,4	9,9	9,3	8,5	8,1	6,5	3,7				
DOC7VX(T)	0,55	0,75	7,2	6,8	6,4	6,0	5,5	4,8	4,5	3,1					

These performances are valid for liquids with density $\rho = 1,0 \text{ kg/dm}^3$ and kinematic viscosity $\nu = 1 \text{ mm}^2/\text{s}$.

doc-2p50-en_b_th

ELECTRICAL DATA TABLE

PUMP TYPE	ABSORBED POWER*	ABSORBED CURRENT*	CAPACITOR
SINGLE-PHASE		220-240 V	
	kW	A	$\mu\text{F} / 450 \text{ V}$
DOC 3	0,31	1,43	6,3
DOC 7	0,78	3,47	16
DOC 7VX	0,66	2,96	16

PUMP TYPE	ABSORBED POWER*	ABSORBED CURRENT*	ABSORBED CURRENT*
THREE-PHASE		220-240 V	380-415 V
	kW	A	A
-	-	-	-
DOC 7T	0,79	2,82	1,63
DOC 7VXT	0,66	2,68	1,55

*Maximum values within operating range

doc-2p50-en_a_te



ITT

Lowara

DOC SERIES DIMENSIONS AND WEIGHTS

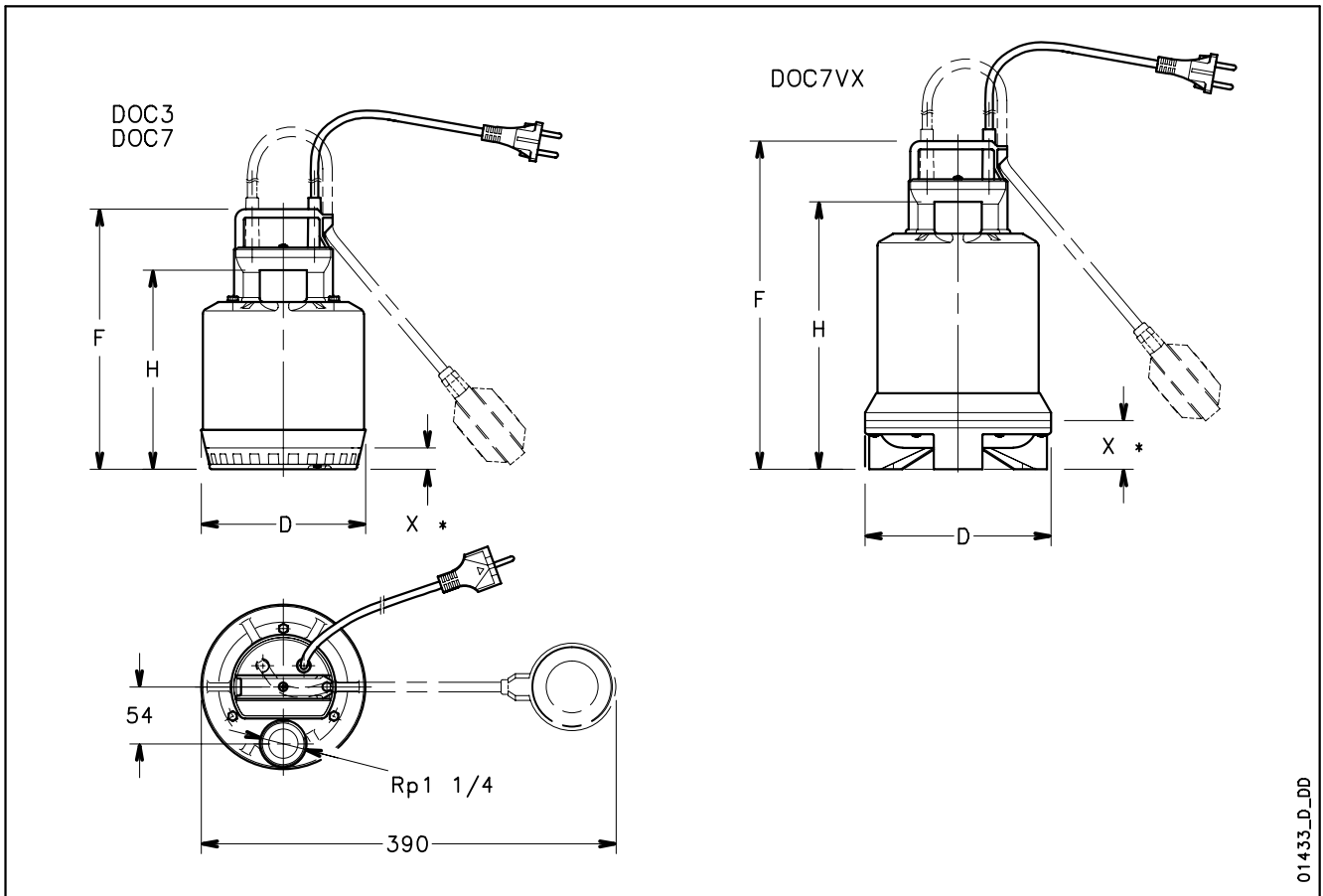

01433_D_DD

PUMP TYPE		DIMENSIONS (mm)				WEIGHT
		F	H	D	X*	kg
DOC3	DOC3 GT	245	188	155	20	4
DOC7(T)	DOC7(T) GT	285	228	155	20	6
DOC7VX(T)	-	310	252	175	45	6

* Minimum liquid level.

doc-2p50-en_b_td

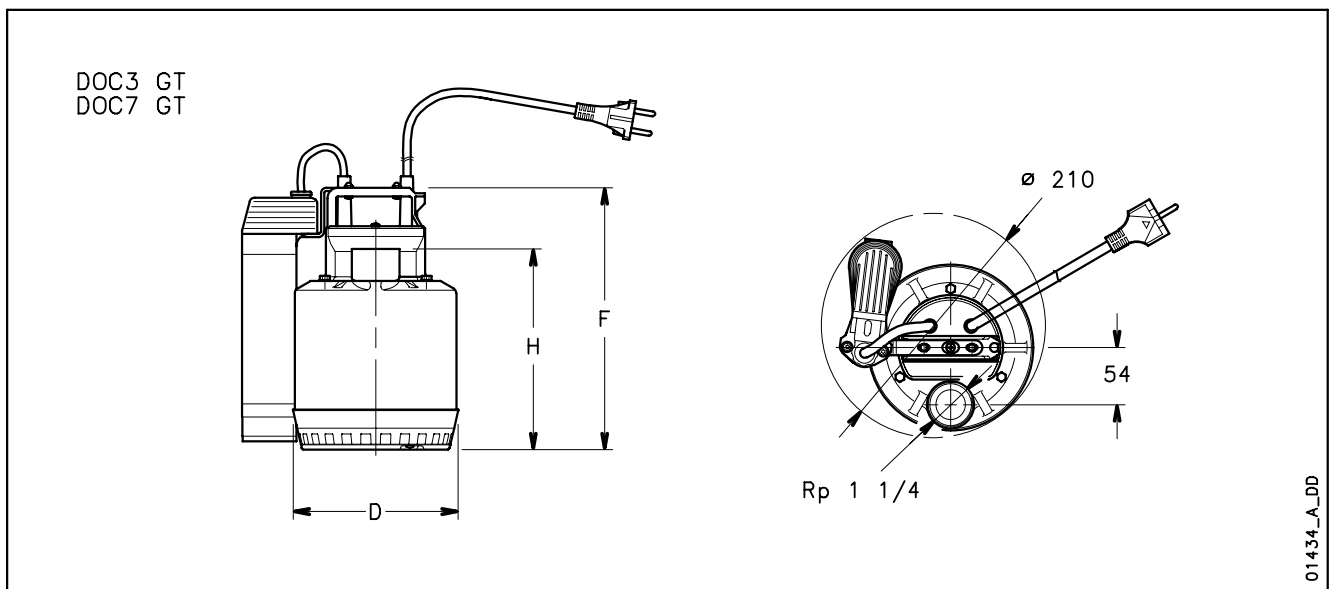

01434_A_DD



ITT

Lowara

DOC SERIES INSTALLATION EXAMPLES

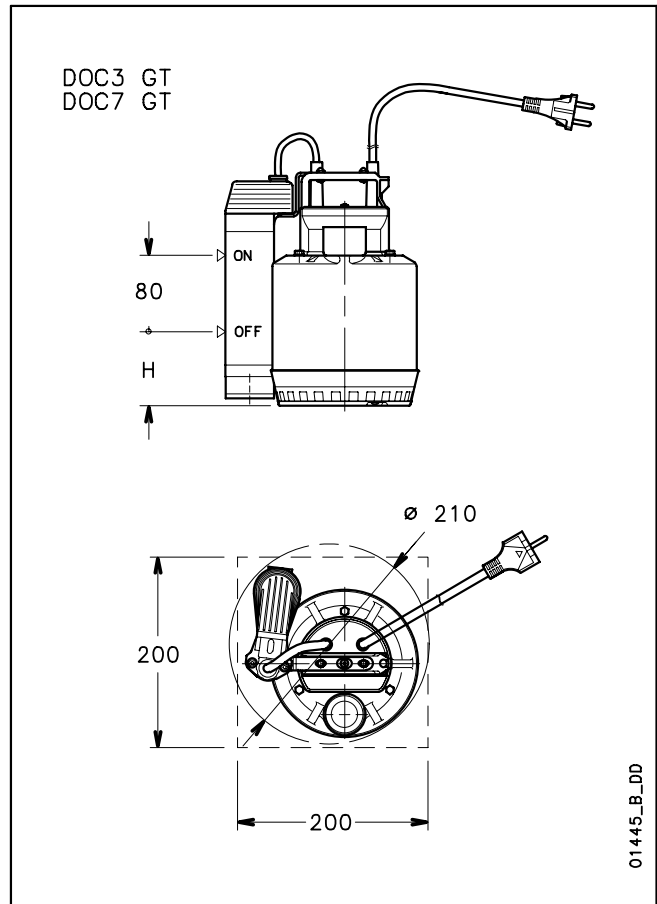
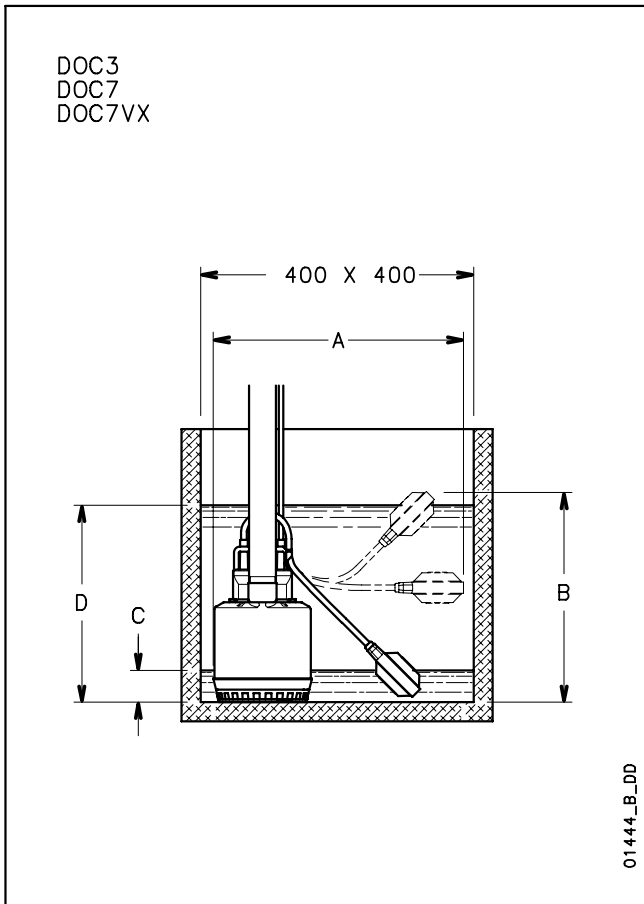

PUMP TYPE		DIMENSIONS (mm)		MINIMUM WATER LEVEL	MAXIMUM WATER LEVEL	MINIMUM WATER LEVEL
		A	B	C	D	H
DOC3	DOC3 GT	390	330	50	310	90
DOC7	DOC7 GT	390	370	90	350	90
DOC7VX	-	390	395	115	375	-

docliv-2p50-en_c_td

ACCESSORIES

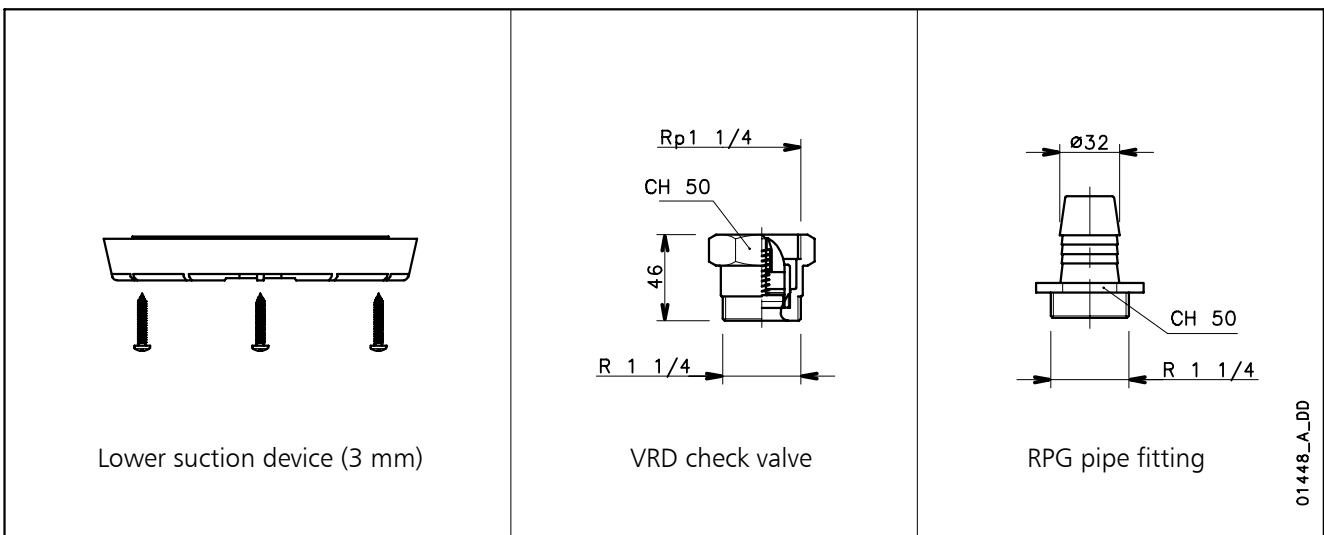

Submersible Electric Pumps for clean and slight dirty water

Submersible pumps for clean and slight dirty water manufactured in AISI 304 stainless steel. Head up to 20 metres, delivery up to 420 l/min (25,2 m³/h). Four basic models with 0,55 to 1,5 kW.

DRIVELUB SEAL SYSTEM.

Diffuser plate coated with polyurethane for maximum resistance to abrasion.

DIWA Series



APPLICATIONS

- Draining of cellars, garages, basements.
- Draining of construction sites.
- Emptying of tanks and reservoirs.
- Lawn and garden irrigation.
- Fountains.
- Pumping of domestic wastewater washing machines, showers, sinks.
- Emptying of tanks in industrial and ecological applications.

SPECIFICATIONS

- Liquid **temperature** up to **50°C**.
- **Open impeller**.
- Minimum level of pumped liquid: **25 mm**.
- **Suspended solids handled up to 8 mm in diameter**.
- **Maximum immersion depth: 7 m**.
- **10 metres of H07RN-F** type neoprene power **cord**.
- **Dry motor** (class F insulation) cooled by pumped liquid.

• Versions:

- Single-phase: 220-240 V, 50 Hz
2 poles with built-in thermal protector.
- Three-phase: 220-240 V, 50 Hz
380-415 V, 50 Hz
2 poles.

• Motor power:

- **0,55 to 1,1 kW** for single-phase version.
- **0,55 to 1,5 kW** for three-phase version.

• The single-phase versions features:

- **Pre-assembled float** (version without float available on request).
- **Built-in capacitor** (except DIWA 11 model with control box on cable).
- **Thermal protector**.

- 60 Hz and versions without float (SG) available.

DRIVELUB SEAL SYSTEM

- Waterlight electric motor protected by multiple seal system with **oil chamber**.

A **V-ring** and **silicon carbide mechanical seal** (extremely resistant to wear and abrasion), as well as a **lip seal** which is continuously lubricated by the **DRIVELUB system**, provide an extremely barrier against infiltration.

DIWA SERIES IDENTIFICATION CODE

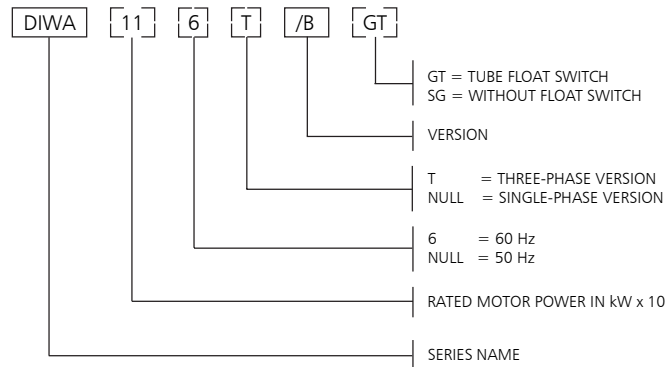

EXAMPLE : DIWA 11/B
DIWA Series Electric pump, rated motor power 1,1 kW,
50 Hz version, single-phase, /B version.

SINGLE-PHASE RATING PLATE

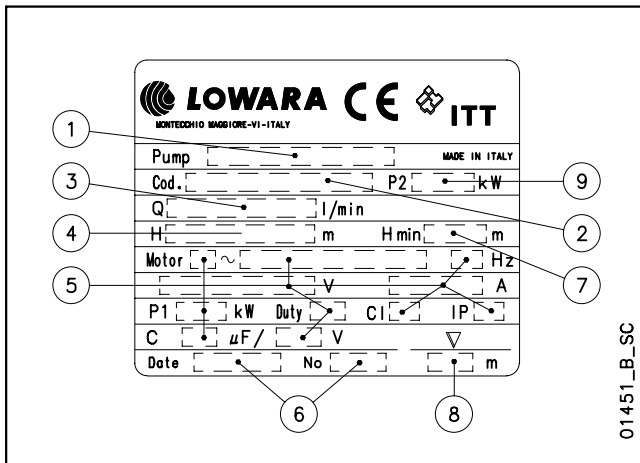

LEGEND

- 1 - Electric pump type
- 2 - Code
- 3 - Delivery range
- 4 - Head range
- 5 - Motor type
- 6 - Date of manufacture and serial number
- 7 - Minimum head
- 8 - Maximum immersion depth
- 9 - Rated output

THREE-PHASE RATING PLATE

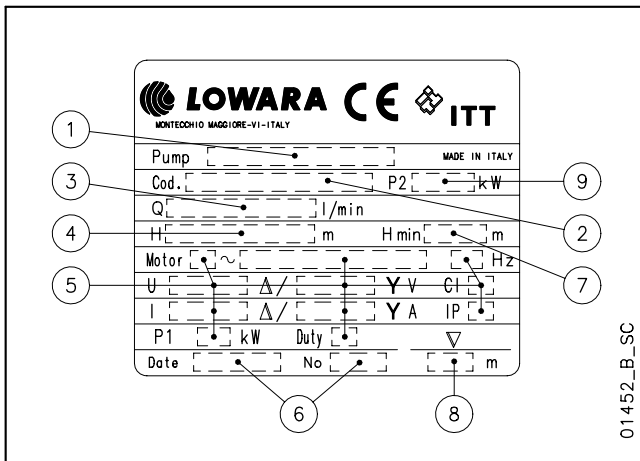



ITT

Lowara

DIWA SERIES LIST OF MODELS AND TABLE OF MATERIALS

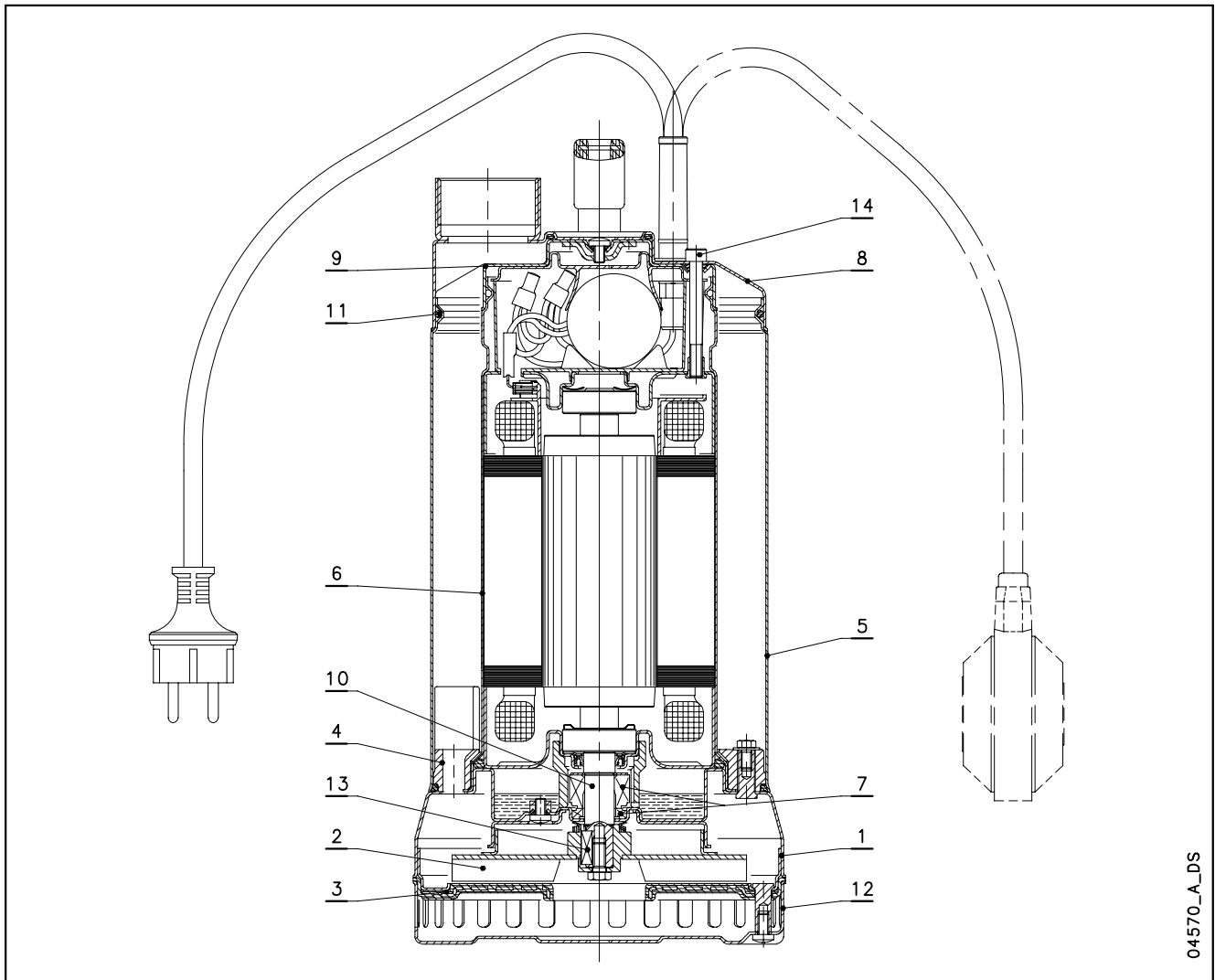

04570_A_DS

REF. N.	NAME	MATERIAL	REFERENCE STANDARDS	
			EUROPE	USA
1	Pump body	Stainless steel	EN 10088-1-X5CrNi18-10 (1.4301)	AISI 304
2	Impeller	Stainless steel	EN 10088-1-X5CrNi18-10 (1.4301)	AISI 304
3	Suction flange	Stainless steel	EN 10088-1-X5CrNi18-10 (1.4301)	AISI 304
		Polyurethane (LARIPUR 9060)		
4	Diffuser	ZITEL 70G30		
5	Sleeve	Stainless steel	EN 10088-1-X5CrNi18-10 (1.4301)	AISI 304
6	Motor casing	Stainless steel	EN 10088-1-X5CrNi18-10 (1.4301)	AISI 304
7	Mechanical seal	Silicon carbide / Silicon carbide / NBR (standard version)		
8	Cover	Stainless steel	EN 10088-1-X5CrNi18-10 (1.4301)	AISI 304
9	Upper cover	Stainless steel	EN 10088-1-X5CrNi18-10 (1.4301)	AISI 304
10	Shaft end	Stainless steel	EN 10088-1-X5CrNi18-10 (1.4301)	AISI 304
11	Elastomers	NBR (standard version)		
12	Strainer	Stainless steel	EN 10088-1-X5CrNi18-10 (1.4301)	AISI 304
13	Key	Stainless steel	EN 10088-1-X5CrNiMo17-12-2 (1.4401)	AISI 316
14	Screws	Stainless steel	EN 10088-1-X5CrNi18-10 (1.4301)	AISI 304

diwa-en_a_tm



ITT

Lowara

**DIWA SERIES
MECHANICAL SEAL**

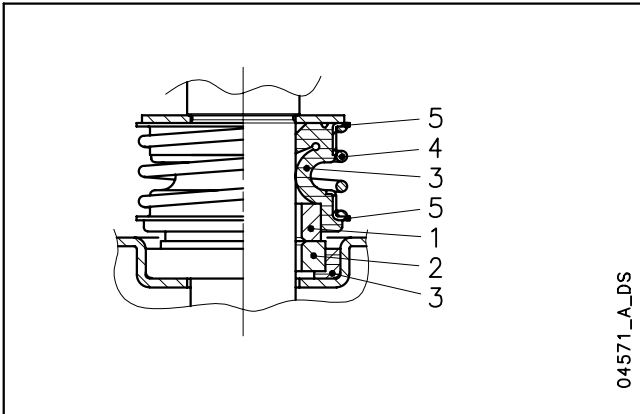

LIST OF MATERIALS

POSITION 1 - 2	POSITION 3	POSITION 4 - 5
Q1 : Silicon carbide	P : NBR	G : AISI 316
	V : FPM	

diwa_ten-mec-en_a_tm

SEAL TYPES

TYPE	POSITION					TEMPERATURE (°C)
	1 ROTATING ASSEMBLY	2 FIXED ASSEMBLY	3 ELASTOMERS	4 SPRINGS	5 OTHER COMPONENTS	
STANDARD MECHANICAL SEAL						
Q ₁ Q ₁ PGG	Q ₁	Q ₁	P	G	G	-5 +50
OTHER MECHANICAL SEAL TYPES						
Q ₁ Q ₁ VGG	Q ₁	Q ₁	V	G	G	-5 +50

diwa_tipi-ten-mec-en_a_tc



ITT

Lowara

DIWA SERIES OPERATING CHARACTERISTICS AT 50 Hz

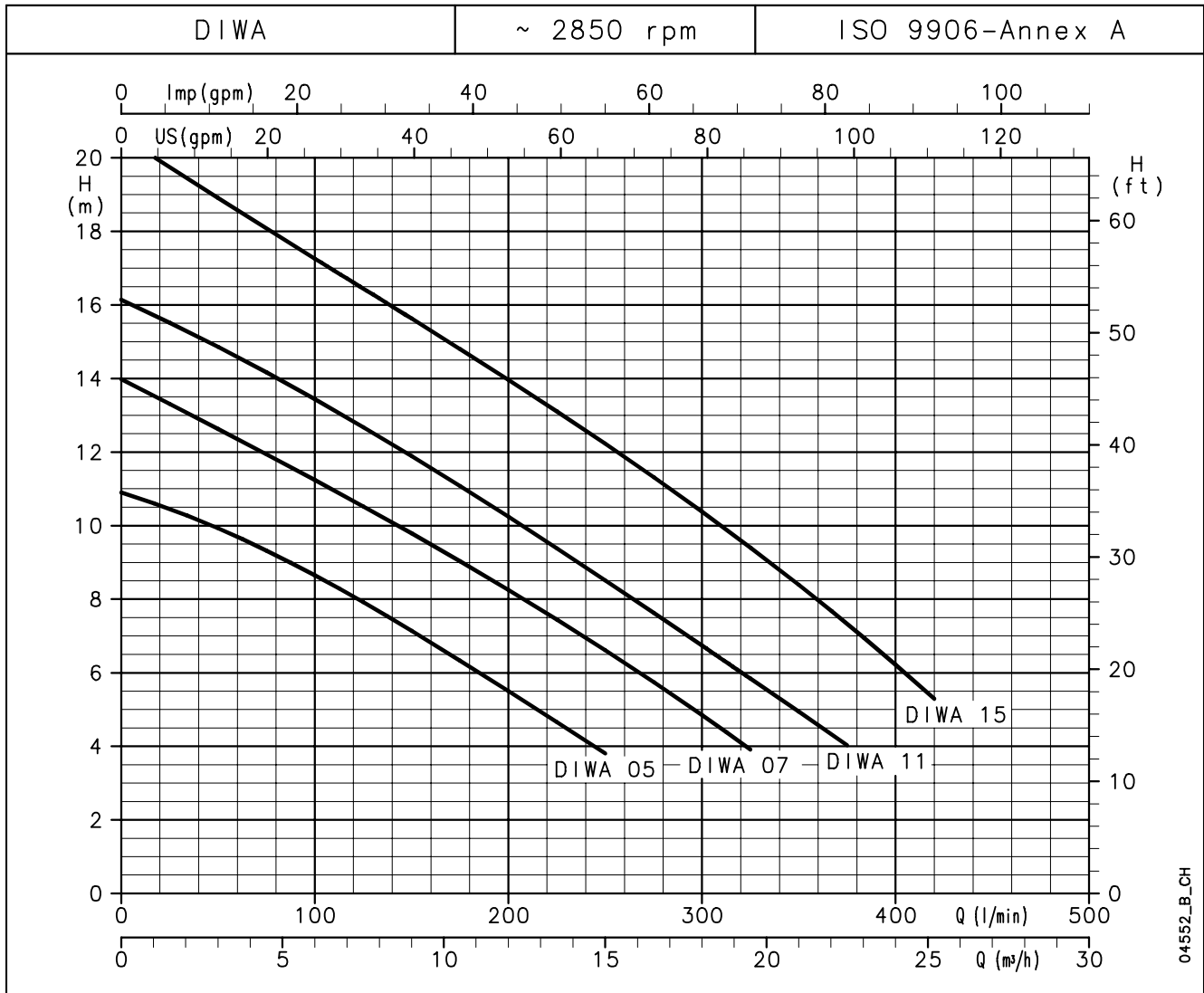

HYDRAULIC PERFORMANCE TABLE

PUMP TYPE	RATED POWER		Q = DELIVERY												
			l/min	0	100	125	150	175	200	225	250	300	325	375	420
			m ³ /h	0	6	7,5	9	10,5	12	13,5	15	18	19,5	22,5	25,2
		H = TOTAL HEAD METRES COLUMN OF WATER													
	kW	HP													
DIWA 05(T)	0,55	0,75	10,9	8,6	7,9	7,1	6,3	5,5	4,7	3,8					
DIWA 07(T)	0,75	1	14,0	11,2	10,5	9,8	9,0	8,3	7,4	6,6	4,8	3,9			
DIWA 11(T)	1,1	1,5	16,1	13,4	12,7	11,9	11,1	10,2	9,4	8,5	6,7	5,8	4,0		
DIWA 15T	1,5	2	20,6	17,3	16,4	15,6	14,8	14,0	13,1	12,2	10,4	9,4	7,3	5,3	

These performances are valid for liquids with density $\rho = 1,0 \text{ kg/dm}^3$ and kinematic viscosity $\nu = 1 \text{ mm}^2/\text{s}$.

diwa-2p50-en_a_th

ELECTRICAL DATA TABLE

PUMP TYPE	ABSORBED POWER*	ABSORBED CURRENT*	CAPACITOR
SINGLE-PHASE	kW	220-240 V A	$\mu\text{F} / 450 \text{ V}$
DIWA 05	0,79	3,92	16
DIWA 07	1,25	6,20	22
DIWA 11	1,53	6,83	30
-	-	-	-

PUMP TYPE	ABSORBED POWER*	ABSORBED CURRENT*	ABSORBED CURRENT*
THREE-PHASE	kW	220-240 V A	380-415 V A
DIWA 05T	0,72	2,56	1,48
DIWA 07T	1,2	4,26	2,46
DIWA 11T	1,44	4,64	2,68
DIWA 15T	2,05	6,74	3,89

*Maximum values within operating range

diwa-2p50-en_a_te



ITT

Lowara

DIWA SERIES DIMENSIONS AND WEIGHTS

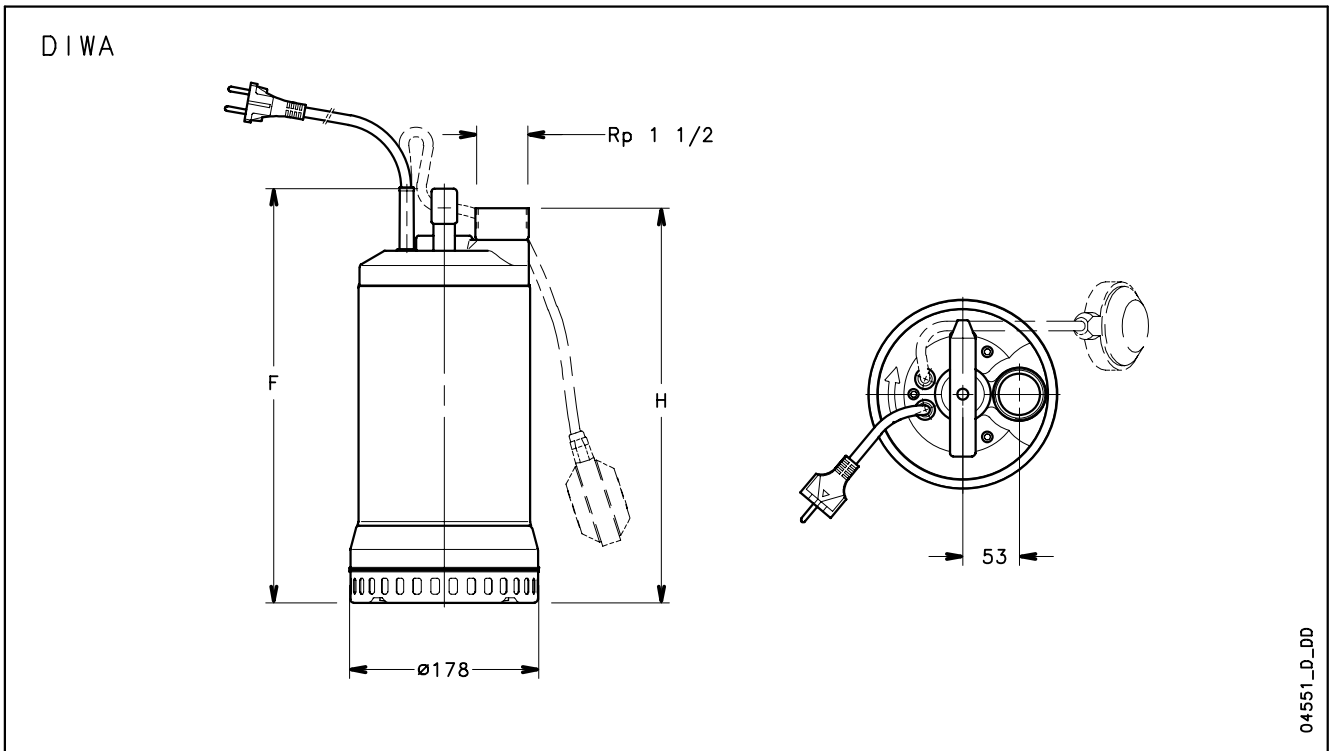

PUMP TYPE SINGLE-PHASE		DIMENSIONS (mm)		WEIGHT
		F	H	kg
DIWA05	DIWA05 GT	348	330	12
DIWA07	DIWA07 GT	393	375	14,3
DIWA11	DIWA11 GT	393	375	17
-	-	-	-	-

PUMP TYPE THREE-PHASE		DIMENSIONS (mm)		WEIGHT
		F	H	kg
DIWA05T		348	330	11
DIWA07T		363	345	13
DIWA11T		393	375	15
DIWA15T		393	375	16,5

diwa-2p50-en_b_td

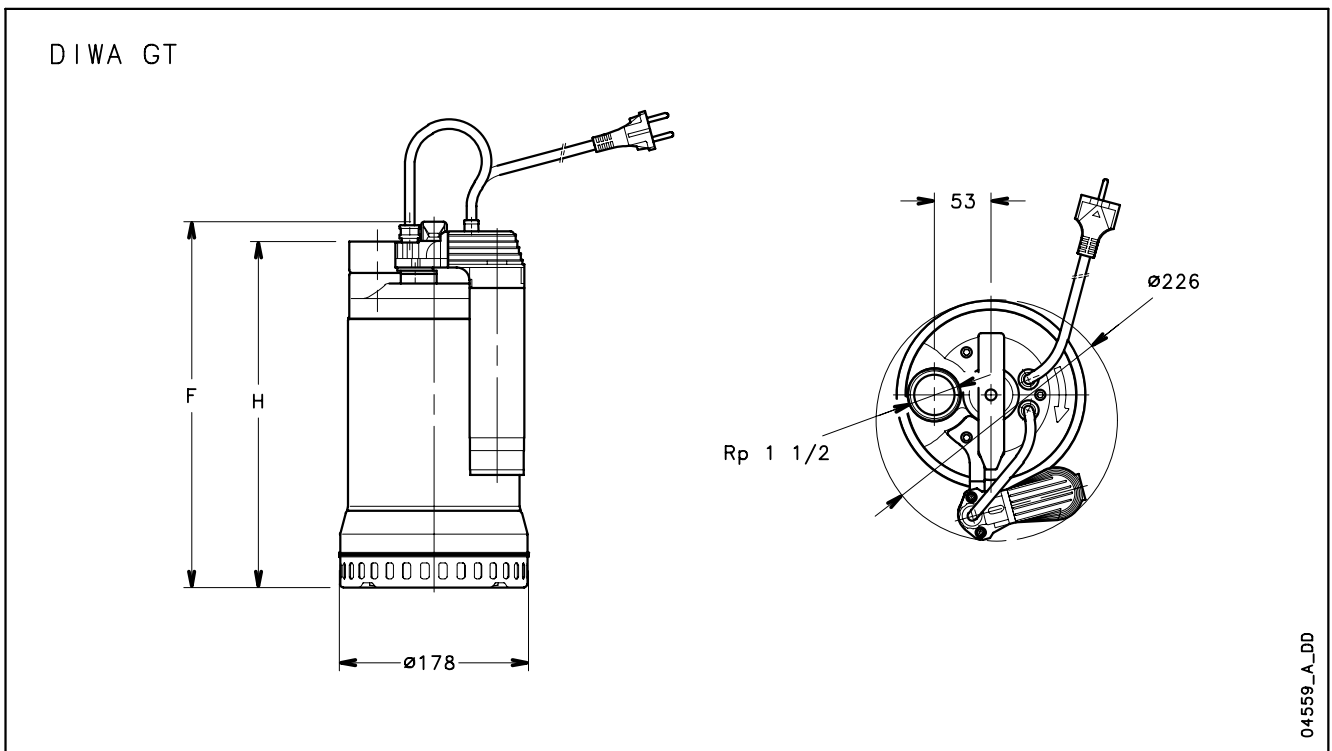



ITT

Lowara

DIWA SERIES INSTALLATION EXAMPLES

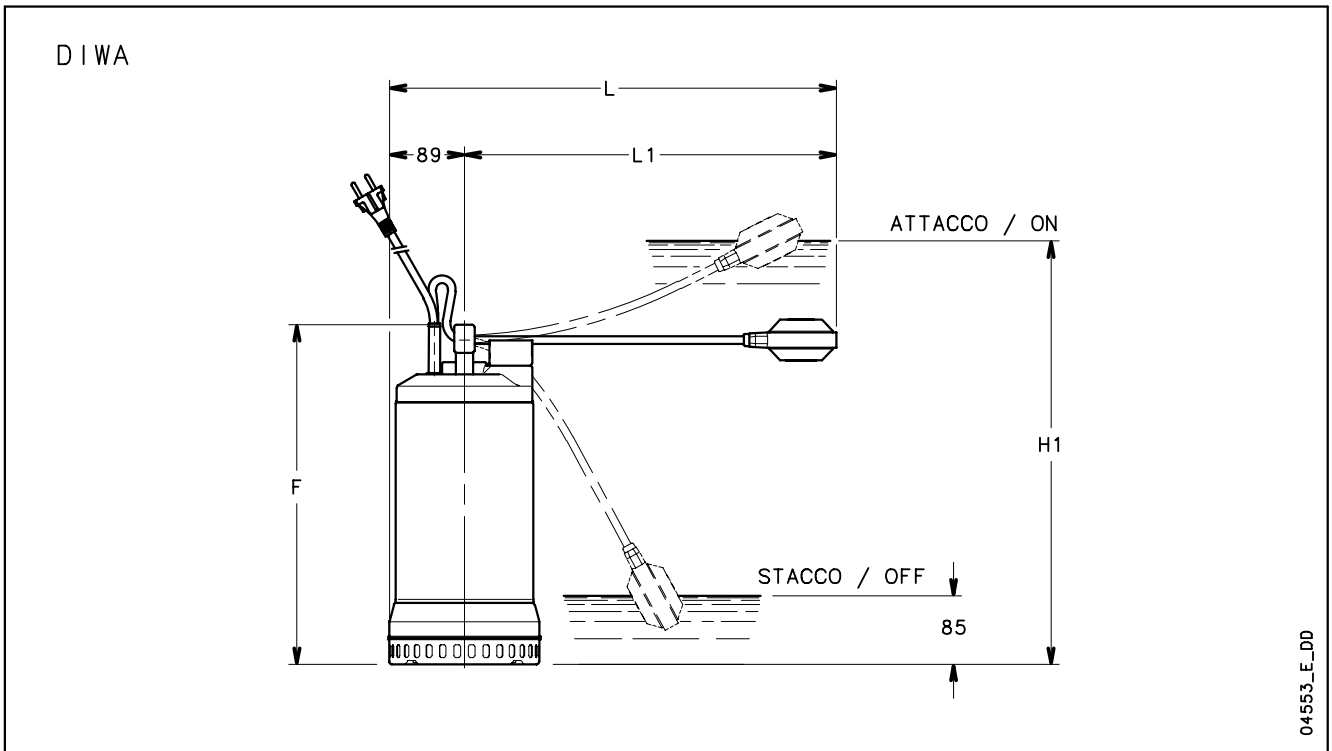

PUMP TYPE		DIMENSIONS (mm)				
		F	L	L1	H1	H2
DIWA05	DIWA05 GT	348	459	370	430	180
DIWA07	DIWA07 GT	393	514	425	490	180
DIWA11	DIWA11 GT	393	514	425	490	180

diwaliv-2p50-en_b_td

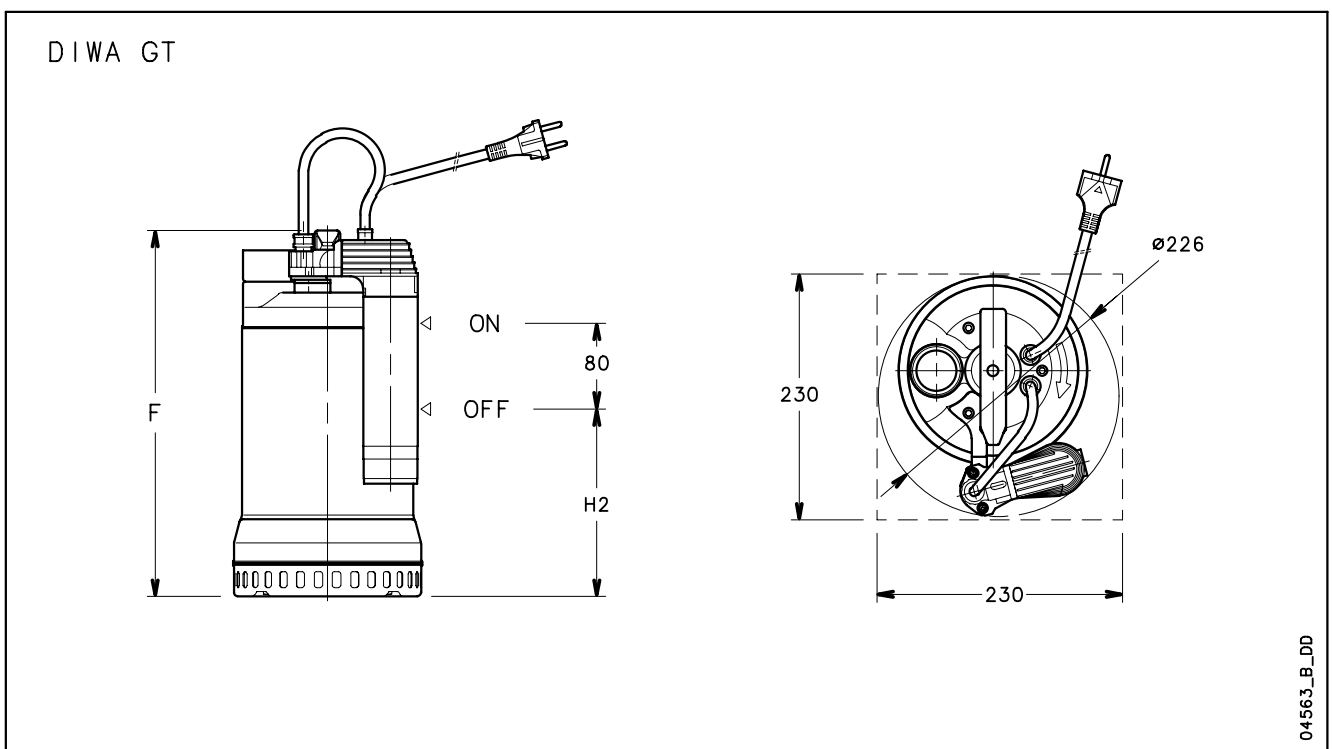



Lowara

Submersible Electric Pumps for dirty water

The DOMO series electric pumps are available with **twin-channel** or **vortex** impeller (DOMO VX). Designed to handle suspended solids up to 50 mm in diameter (35 mm for DOMO 7 and DOMO 7VX). Four basic models with 0,55 to 1,5 kW.

DRIVELUB SEAL SYSTEM.

DOMO Series



APPLICATIONS

- Pumping of effluent (VX model handles also suspended filaments).
- Emptying of septic tanks and residential sumps.
- Draining of flooded basements and garages.

SPECIFICATIONS

- **Continuous duty** with **35°C** liquids and fully submerged pump.
- **Dry motor** (class F insulation).
- **H07RN-F** type neoprene power **cord**.
- **Maximum** immersion **depth: 5 m**.
- **Versions:**
 - Single-phase: 220-240 V, 50 Hz
2 poles.
 - Three-phase: 220-240 V, 50 Hz
380-415 V, 50 Hz
2 poles.
- **Motor power:**
 - **0,55 to 1,1 kW** for single-phase versions.
 - **0,55 to 1,5 kW** for three-phase versions.

- The single-phase versions feature:
 - **Pre-assembled float** (version without float available on request).
 - **Built-in capacitor** (except for DOMO 15 and DOMO 15VX models with control box on cable).
 - **Thermal overload protection.**
- The **DOMO 7** and **DOMO 7VX** versions feature:
 - **Rp 1"1/2 delivery port** (female gas).
 - Handling of suspended **solids up to 35 mm** in diameter.
 - **Fiberglass-reinforced nylon impeller** (stainless steel impeller also available).
- The **DOMO 10-15-20** and **DOMO 10-15-20 VX** versions feature:
 - **Rp 2" delivery port** female gas (can be turned into a flanged version if an optional accessory is installed).
 - Handling of suspended **solids up to 50 mm** in diameter.
 - **Stainless steel twin-channel or vortex impeller.**

DRIVELUB SEAL SYSTEM

- Waterlight electric motor protected by multiple seal system with **oil chamber**.
A **V-ring** and **silicon carbide mechanical seal** (extremely resistant to wear and abrasion), as well as a **lip seal** which is continuously lubricated by the **DRIVELUB system**, provide an extremely barrier against infiltration.



ITT

Lowara

Submersible Electric Pumps for dirty water equipped with grinder system

DOMO GRI Series



The DOMO GRI series electric pumps are equipped with a completely new, extremely efficient and highly reliable grinder system.

The grinder is able to macerate all the solids and the filaments present in the sewage and to pass through smaller discharge pipes (25 mm diameter).

DOMO GRI is available in the 1,1 kW (P2) version.

DRIVELUB SEAL SYSTEM.

- The single-phase versions feature:
 - **Pre-assembled float** (version without float available on request).
 - **Built-in capacitor.**
 - **Thermal overload protection.**
- **DOMO GRI** are equipped with:
 - **Rp 1" delivery port** (female gas).
 - Technopolymer PBT **Impeller.**
 - Stainless steel and high resistance **Grinder.**

DRIVELUB SEAL SYSTEM

- Waterlight electric motor protected by multiple seal system with **oil chamber.**
- A **V-ring** and **silicon carbide mechanical seal** (extremely resistant to wear and abrasion), as well as a **lip seal** which is continuously lubricated by the **DRIVELUB system**, provide an extremely barrier against infiltration.

APPLICATIONS

- Pumping of sewage with suspended solids and filaments.
- Emptying of septic tanks and residential sumps.
- Draining of flooded areas.
- Pumping water from a pressurized sewer network.

SPECIFICATIONS

- **Continuous duty** with **35°C** liquids and fully submerged pump.
- **Dry motor** (class F insulation).
- **H07RN-F** type neoprene power **cord.**
- **Maximum immersion depth: 5 m.**
- **Versions:**
 - Single-phase: 220-240 V, 50 Hz
2 poles.
 - Three-phase: 220-240 V, 50 Hz
380-415 V, 50 Hz
2 poles.
- **Motor power:**
 - **1,1 kW** (P2) for single and three-phase versions.

DOMO SERIES IDENTIFICATION CODE

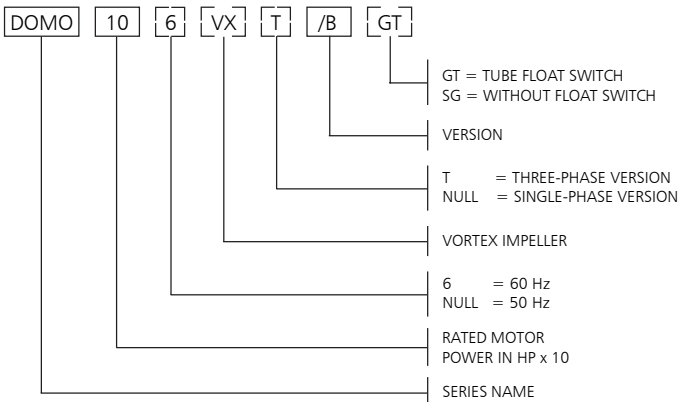

EXAMPLE : DOMO 10/B
 DOMO Series Electric pump, rated motor power 1 HP, 50 Hz version, single-phase, /B version.

DOMO GRI SERIES IDENTIFICATION CODE

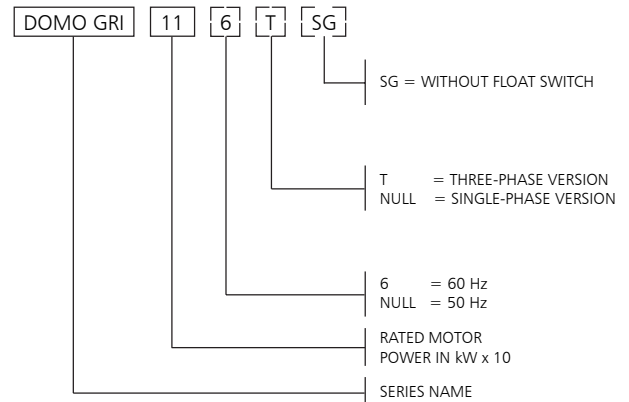

EXAMPLE : DOMO GRI 11
 DOMO GRI (grinder) Series Electric pump, rated motor power 1,1 kW, 50 Hz version, single-phase.

SINGLE-PHASE RATING PLATE

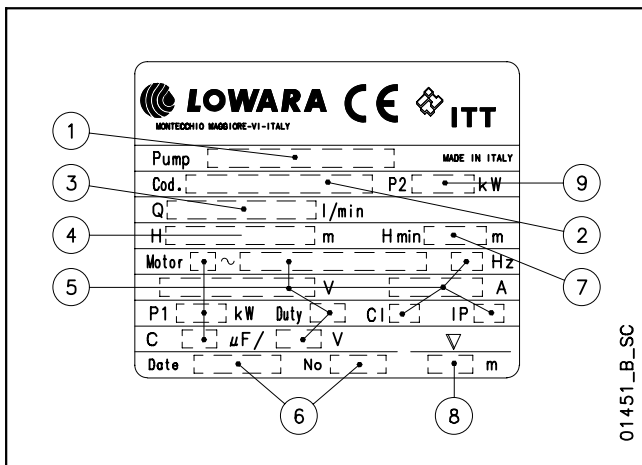

LEGEND

- 1 - Electric pump type
- 2 - Code
- 3 - Delivery range
- 4 - Head range
- 5 - Motor type
- 6 - Date of manufacture and serial number
- 7 - Minimum head
- 8 - Maximum immersion depth
- 9 - Rated output

THREE-PHASE RATING PLATE

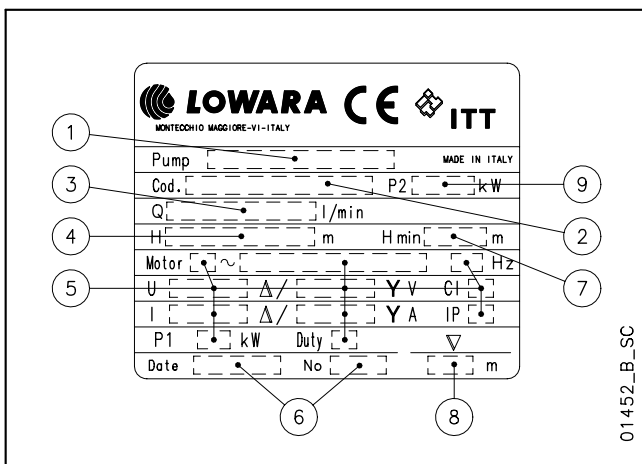



DOMO SERIES LIST OF MODELS AND TABLE OF MATERIALS

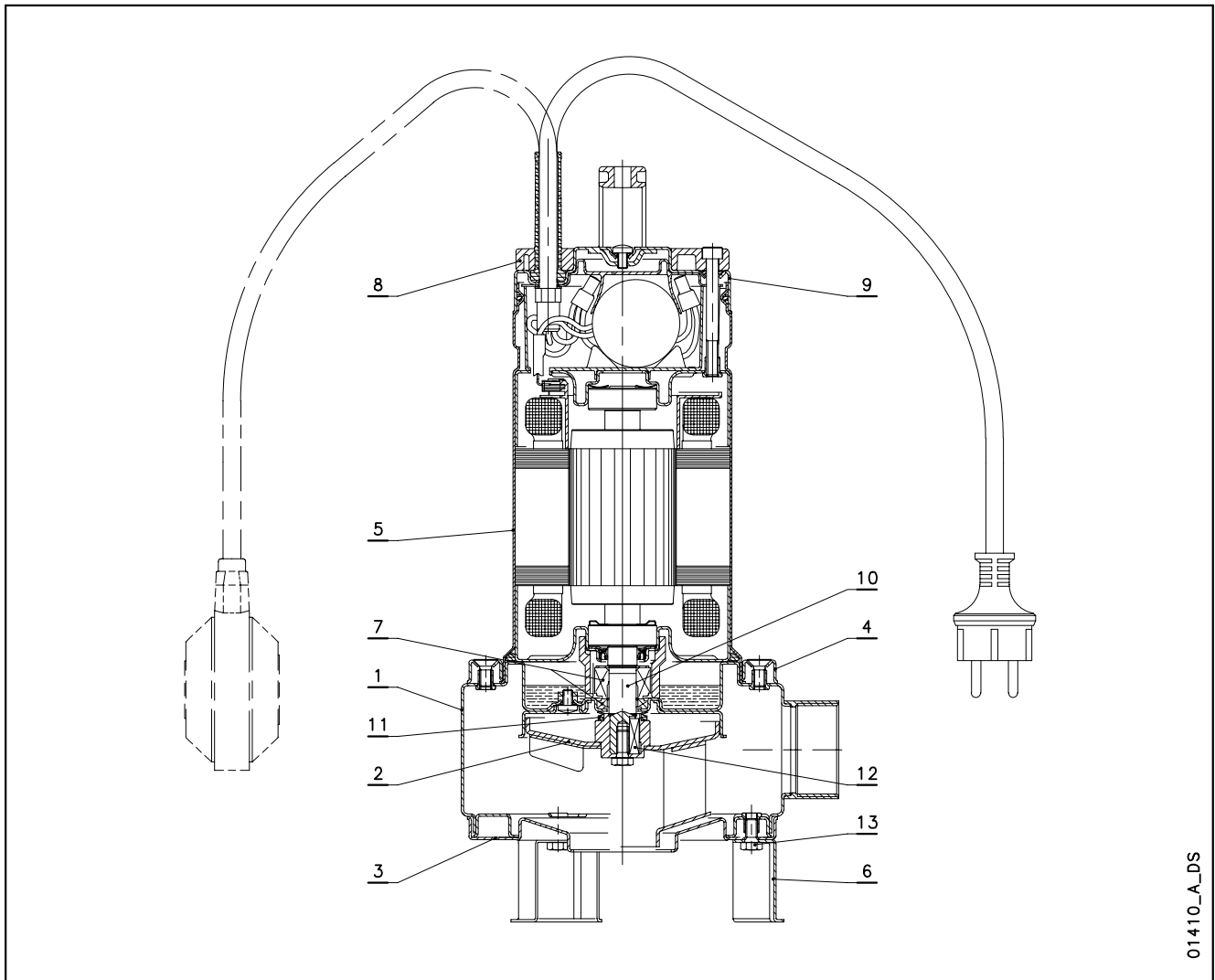

01410_A_DS

REF. N.	NAME	MATERIAL	REFERENCE STANDARDS	
			EUROPE	USA
1	Pump body	Stainless steel	EN 10088-1-X5CrNi18-10 (1.4301)	AISI 304
2	Impeller	NYLON 66 + 30% F.V.		
		Stainless steel	EN 10088-1-X5CrNi18-10 (1.4301)	AISI 304
3	Suction flange	Stainless steel	EN 10088-1-X5CrNi18-10 (1.4301)	AISI 304
4	Fixing ring	Stainless steel	EN 10088-1-X5CrNi18-10 (1.4301)	AISI 304
5	Motor casing	Stainless steel	EN 10088-1-X5CrNi18-10 (1.4301)	AISI 304
6	Support foot	Stainless steel	EN 10088-1-X5CrNi18-10 (1.4301)	AISI 304
7	Mechanical seal	Silicon carbide / Silicon carbide / NBR (standard version)		
8	Handle	NYLON 66 + 30% F.V.		
9	Upper cover	Stainless steel	EN 10088-1-X5CrNi18-10 (1.4301)	AISI 304
10	Shaft end	Stainless steel	EN 10088-1-X5CrNi18-10 (1.4301)	AISI 304
11	Elastomers	NBR (standard version)		
12	Key	Stainless steel	EN 10088-1-X5CrNiMo17-12-2 (1.4401)	AISI 316
13	Screws	Stainless steel	EN 10088-1-X5CrNi18-10 (1.4301)	AISI 304



DOMO GRI SERIES LIST OF MODELS AND TABLE OF MATERIALS

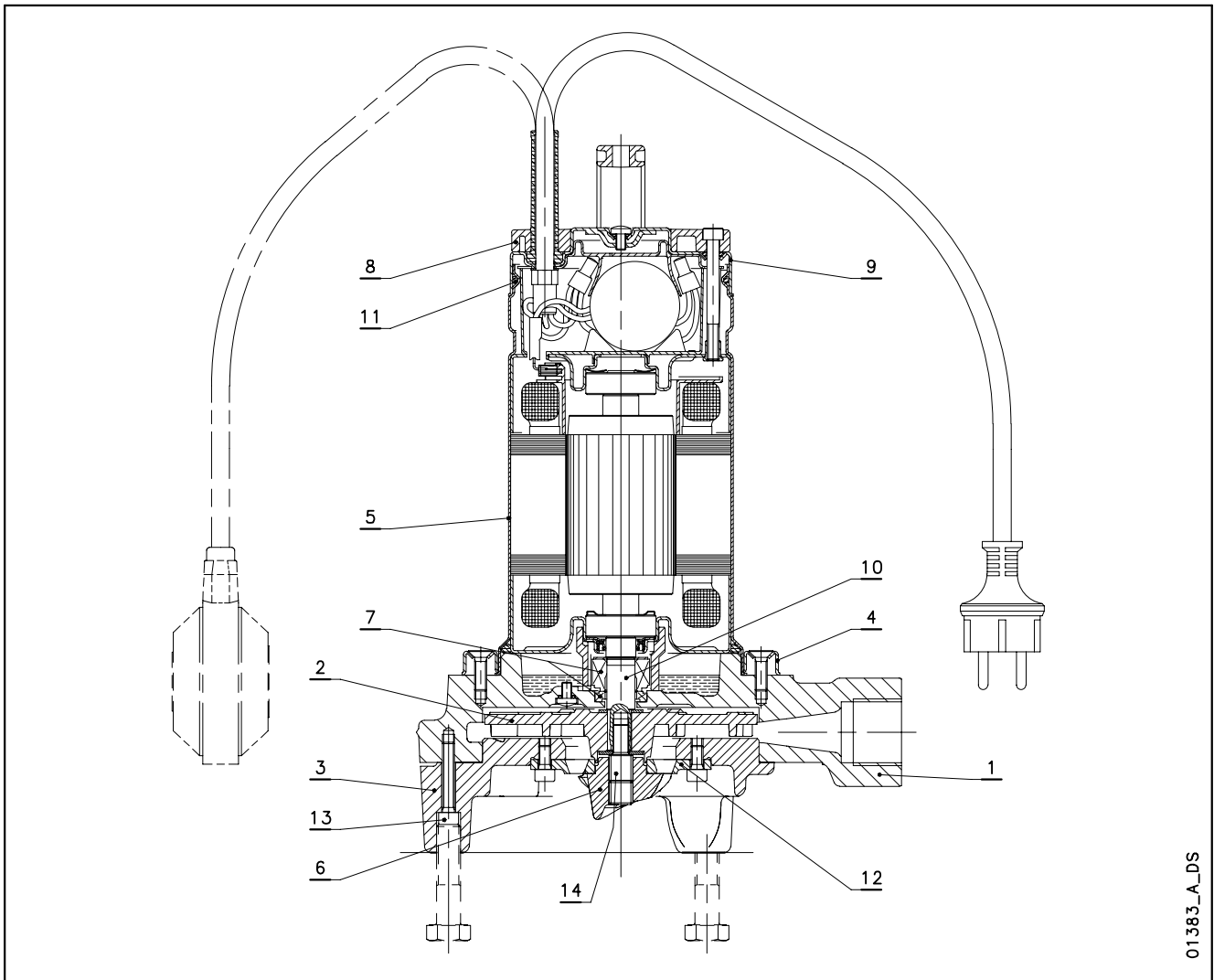

01383_A_DS

REF. N.	NAME	MATERIAL	REFERENCE STANDARDS	
			EUROPE	USA
1	Pump body	Cast iron	EN 1561-GJL-250 (JL1040)	ASTM Class 35
2	Impeller	PBT		
3	Suction cover	Cast iron	EN 1561-GJL-250 (JL1040)	ASTM Class 35
4	Fixing ring	Stainless steel	EN 10088-1-X5CrNi18-10 (1.4301)	AISI 304
5	Motor casing	Stainless steel	EN 10088-1-X5CrNi18-10 (1.4301)	AISI 304
6	Cutter wheel	Stainless steel	X95CrMoV17 (DIN 1.4535)	-
7	Mechanical seal	Silicon carbide / Silicon carbide / NBR (standard version)		
8	Handle	NYLON 66 + 30% F.V.		
9	Upper cover	Stainless steel	EN 10088-1-X5CrNi18-10 (1.4301)	AISI 304
10	Shaft end	Stainless steel	EN 10088-1-X5CrNi18-10 (1.4301)	AISI 304
11	Elastomers	NBR (standard version)		
12	Cutter ring	Stainless steel	X95CrMoV17 (DIN 1.4535)	-
13	Screws	Stainless steel	EN 10088-1-X5CrNi18-10 (1.4301)	AISI 304
14	Impeller fixing screw + wheel	Stainless steel	EN 10088-1-X17CrNi16-2 (1.4057)	AISI 431

domo-gri-en_b_tm



ITT

Lowara

DOMO - DOMO GRI SERIES MECHANICAL SEAL

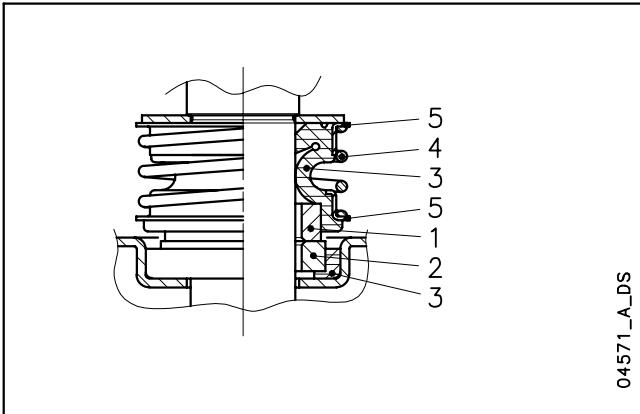

LIST OF MATERIALS

POSITION 1 - 2	POSITION 3	POSITION 4 - 5
Q1 : Silicon carbide	P : NBR	G : AISI 316
	V : FPM	

diwa_ten-mec-en_a_tm

SEAL TYPES

TYPE	POSITION					TEMPERATURE (°C)
	1 ROTATING ASSEMBLY	2 FIXED ASSEMBLY	3 ELASTOMERS	4 SPRINGS	5 OTHER COMPONENTS	
STANDARD MECHANICAL SEAL						
Q ₁ Q ₁ PGG	Q ₁	Q ₁	P	G	G	-5 +35
OTHER MECHANICAL SEAL TYPES						
Q ₁ Q ₁ VGG	Q ₁	Q ₁	V	G	G	-5 +35

domo_tipi-ten-mec-en_a_tc



ITT

Lowara

DOMO SERIES OPERATING CHARACTERISTICS AT 50 Hz

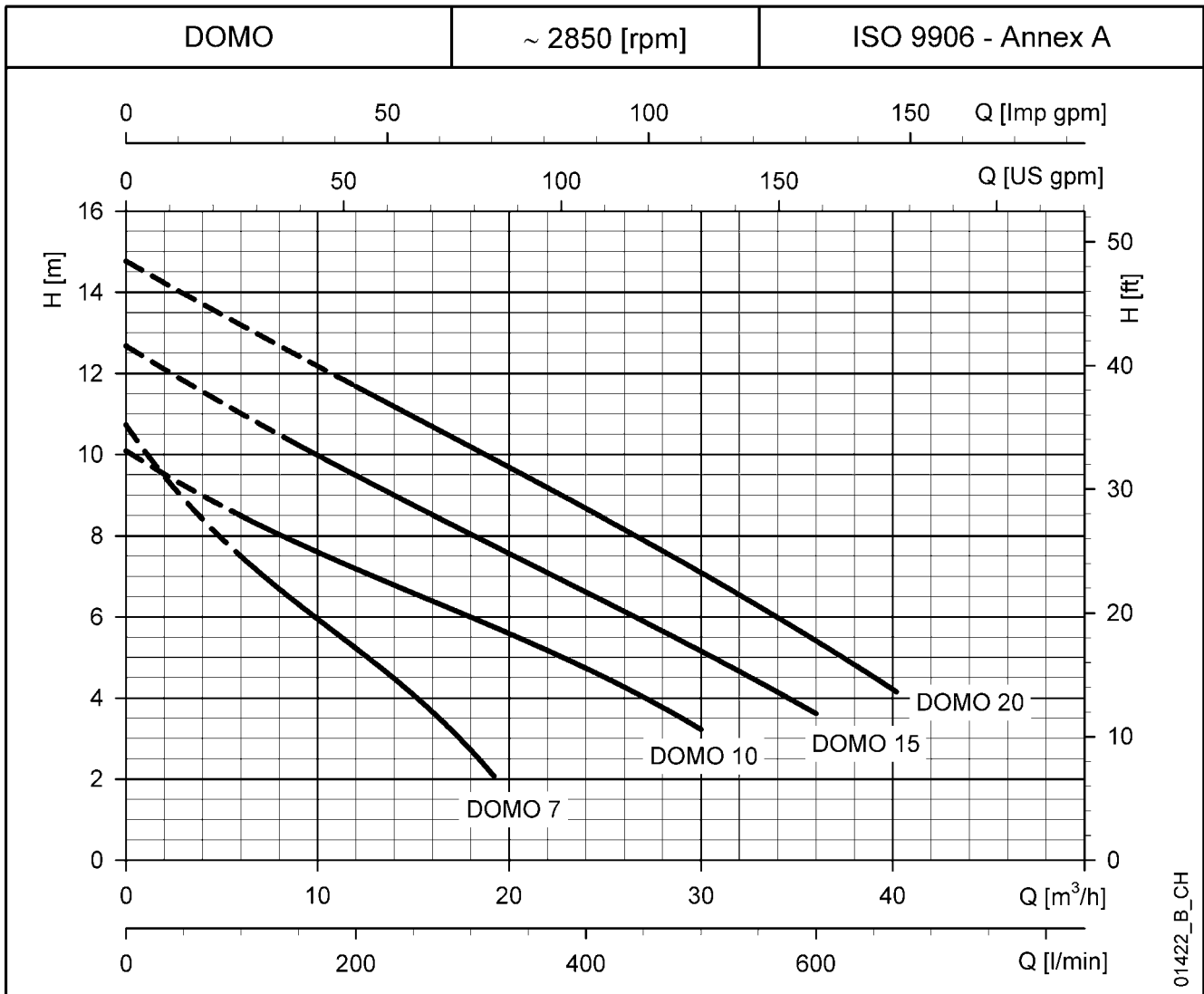

HYDRAULIC PERFORMANCE TABLE

PUMP TYPE	RATED POWER		Q = DELIVERY											
			l/min	0	100	150	200	250	300	320	400	500	600	670
			m ³ /h	0	6	9	12	15	18	19,2	24	30	36	40,2
	kW	HP	H = TOTAL HEAD METRES COLUMN OF WATER											
DOMO 7(T)	0,55	0,75	10,7	7,5	6,3	5,2	4,1	2,7	2,1					
DOMO 10(T)	0,75	1	10,1	8,5	7,8	7,2	6,6	6,0	5,8	4,7	3,2			
DOMO 15(T)	1,1	1,5	12,7	11,0	10,2	9,5	8,8	8,0	7,8	6,6	5,2	3,6		
DOMO 20T	1,5	2	14,8	13,2	12,4	11,7	10,9	10,2	9,9	8,7	7,1	5,4	4,2	

These performances are valid for liquids with density $\rho = 1,0 \text{ kg/dm}^3$ and kinematic viscosity $\nu = 1 \text{ mm}^2/\text{s}$.

domo-2p50-en_a_th

ELECTRICAL DATA TABLE

PUMP TYPE	ABSORBED POWER*	ABSORBED CURRENT*	CAPACITOR
SINGLE-PHASE	kW	220-240 V A	$\mu\text{F} / 450 \text{ V}$
DOMO 7	0,80	3,94	16
DOMO 10	1,14	5,84	22
DOMO 15	1,58	7,02	30
-	-	-	-

PUMP TYPE	ABSORBED POWER*	ABSORBED CURRENT*	ABSORBED CURRENT*
THREE-PHASE	kW	220-240 V A	380-415 V A
DOMO 7T	0,73	2,58	1,49
DOMO 10T	1,09	4,09	2,36
DOMO 15T	1,49	4,73	2,73
DOMO 20T	1,96	6,6	3,81

*Maximum values within operating range

domo-2p50-en_a_te



DOMO VX SERIES OPERATING CHARACTERISTICS AT 50 Hz

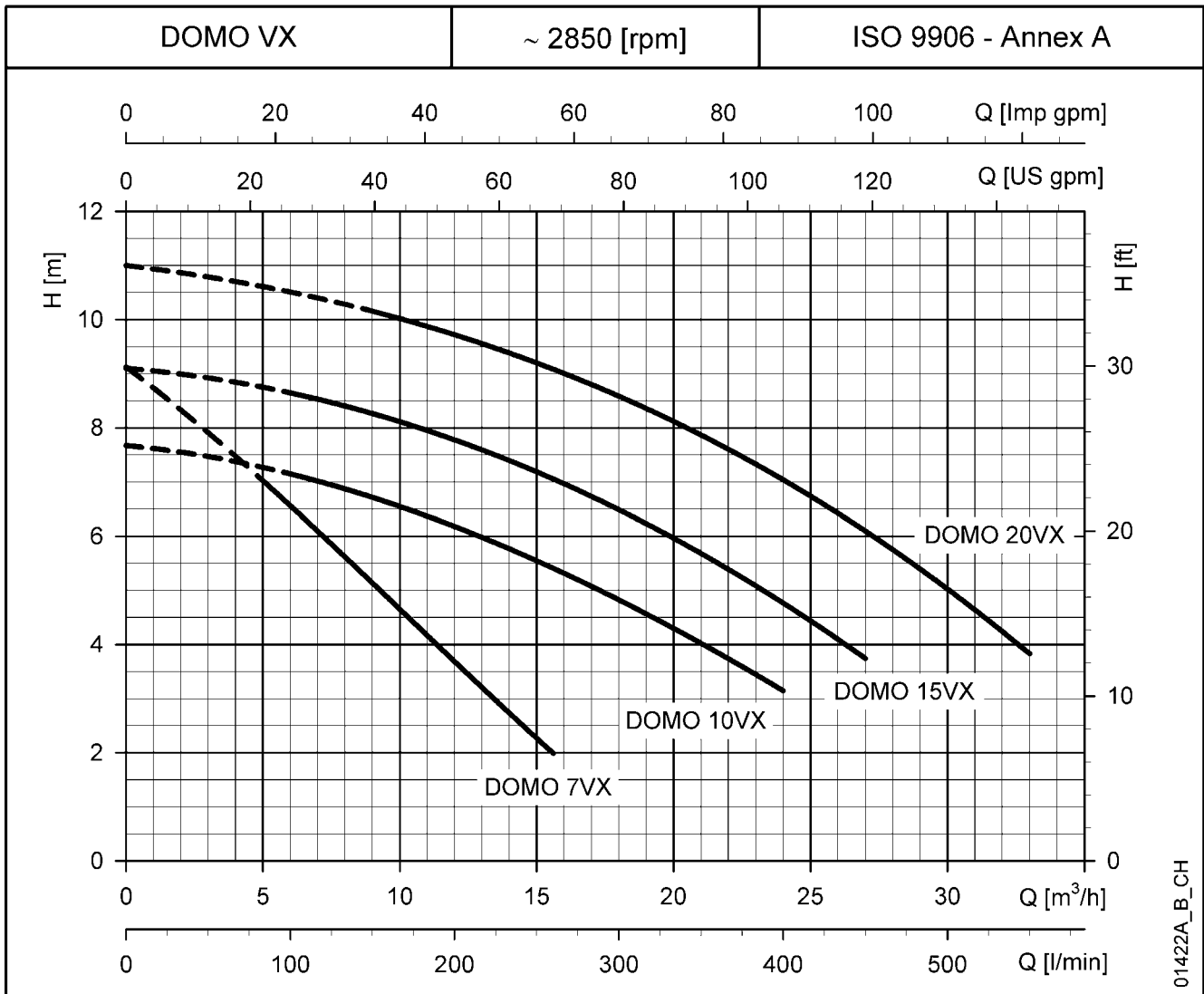

HYDRAULIC PERFORMANCE TABLE

PUMP TYPE	RATED POWER		Q = DELIVERY												
			l/min	0	80	100	150	175	200	225	260	300	400	450	550
			m³/h	0	4,8	6	9	10,5	12	13,5	15,6	18	24	27	33
	kW	HP	H = TOTAL HEAD METRES COLUMN OF WATER												
DOMO 7VX(T)	0,55	0,75	9,1	7,1	6,6	5,1	4,4	3,7	3,0	2,0					
DOMO 10VX(T)	0,75	1	7,7	7,3	7,1	6,7	6,5	6,2	5,9	5,4	4,8	3,1			
DOMO 15VX(T)	1,1	1,5	9,1	8,8	8,6	8,3	8,0	7,8	7,5	7,1	6,5	4,8	3,7		
DOMO 20VXT	1,5	2	11,0	10,6	10,5	10,2	9,9	9,7	9,5	9,1	8,6	7,0	6,1	3,8	

These performances are valid for liquids with density $\rho = 1,0 \text{ kg/dm}^3$ and kinematic viscosity $\nu = 1 \text{ mm}^2/\text{s}$.

domovx-2p50-en_a_th

ELECTRICAL DATA TABLE

PUMP TYPE	ABSORBED POWER*	ABSORBED CURRENT*	CAPACITOR
SINGLE-PHASE	kW	220-240 V A	$\mu\text{F} / 450 \text{ V}$
DOMO 7VX	0,79	3,91	16
DOMO 10VX	1,15	5,88	22
DOMO 15VX	1,36	6,11	30
-	-	-	-

PUMP TYPE	ABSORBED POWER*	ABSORBED CURRENT*	ABSORBED CURRENT*
THREE-PHASE	kW	220-240 V A	380-415 V A
DOMO 7VXT	0,71	2,56	1,48
DOMO 10VXT	1,10	4,09	2,36
DOMO 15VXT	1,26	4,31	2,49
DOMO 20VXT	1,74	6,22	3,59

*Maximum values within operating range

domovx-2p50-en_a_te



ITT

Lowara

DOMO GRI SERIES OPERATING CHARACTERISTICS AT 50 Hz

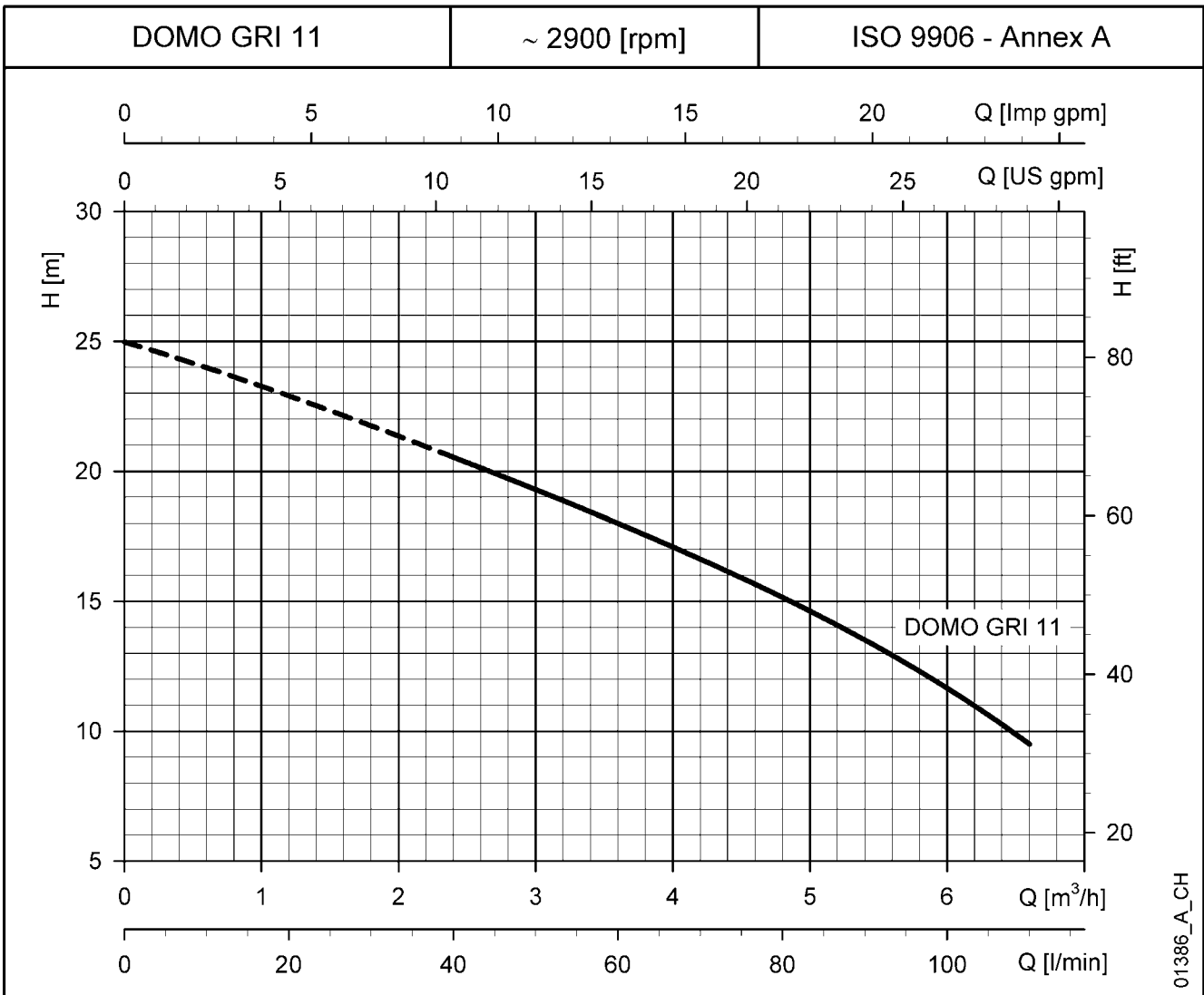

HYDRAULIC PERFORMANCE TABLE

PUMP TYPE	RATED POWER		Q = DELIVERY											
			l/min	0	15	30	40	50	60	70	80	90	100	110
			m ³ /h	0	0,9	1,8	2,4	3	3,6	4,2	4,8	5,4	6	6,6
			H = TOTAL HEAD METRES COLUMN OF WATER											
DOMO GRI 11 (SG)	1,1	1,5	25,0	23,5	21,7	20,5	19,3	18,0	16,6	15,2	13,5	11,7	9,5	
DOMO GRI 11 T														

These performances are valid for liquids with density $\rho = 1,0 \text{ kg/dm}^3$ and kinematic viscosity $\nu = 1 \text{ mm}^2/\text{s}$.

domo-gri-2p50-en_a_th

ELECTRICAL DATA TABLE

PUMP TYPE	RATED POWER*	ABSORBED CURRENT*	CAPACITOR	PUMP TYPE	RATED POWER*	ABSORBED CURRENT*	ABSORBED CURRENT*
SINGLE-PHASE	kW	220-240 V	$\mu\text{F} / 450 \text{ V}$	THREE-PHASE	kW	220-240 V	380-415 V
		A		A		A	
DOMO GRI 11 (SG)	1,50	6,84	30	DOMO GRI 11 T	1,39	4,55	2,63

* Maximum value in specified range

domo-gri-2p50-en_b_th



ITT

Lowara

DOMO SERIES DIMENSIONS AND WEIGHTS

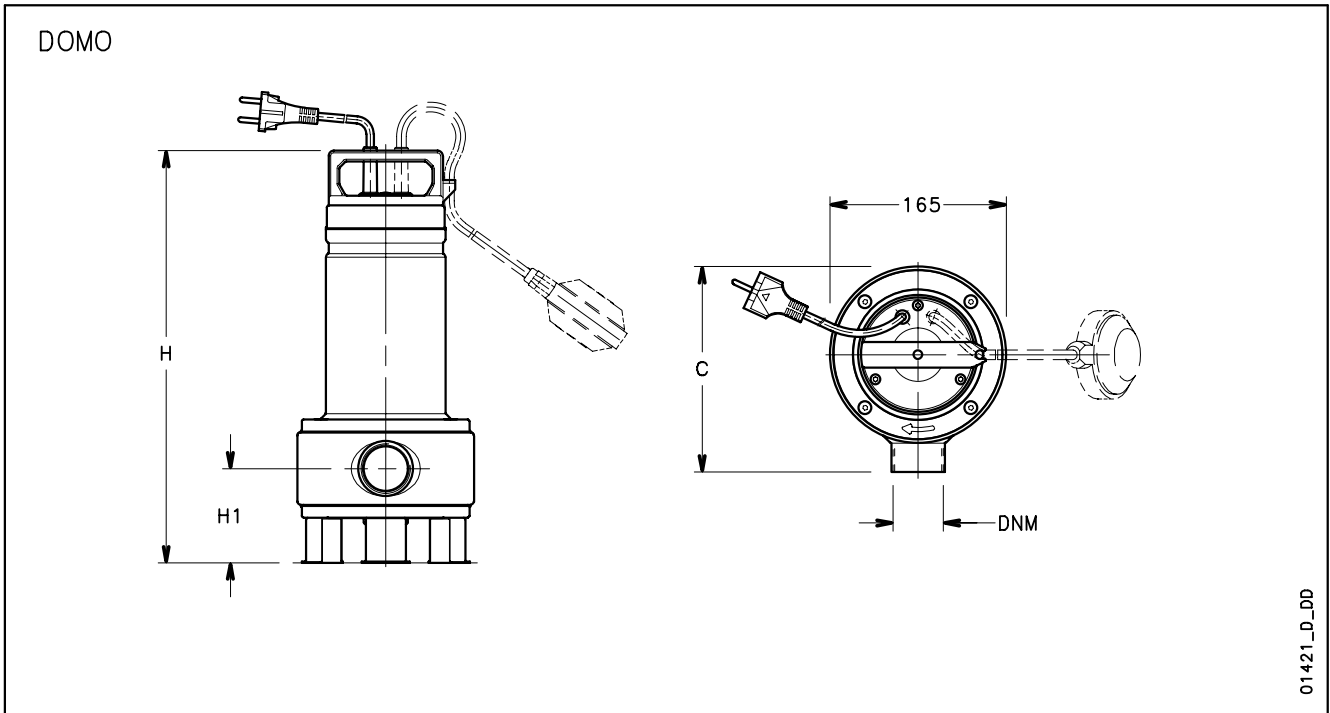

PUMP TYPE SINGLE-PHASE		DIMENSIONS (mm)			DNM	WEIGHT kg
		H	H1	C		
DOMO 7	DOMO 7 GT	391	88	193	Rp1½	10,2
DOMO 7VX	DOMO 7VX GT					
DOMO10	DOMO10 GT	468	111,5	198	Rp2	13,6
DOMO10VX	DOMO10VX GT					
DOMO15	DOMO15 GT	468	111,5	198	Rp2	15,3
DOMO15VX	DOMO15VX GT					
-	-	-	-	-	-	-

PUMP TYPE THREE-PHASE		DIMENSIONS (mm)			DNM	WEIGHT kg
		H	H1	C		
DOMO 7T	DOMO 7VXT	391	88	193	Rp1½	8,9
DOMO10T	DOMO10VXT					
DOMO15T	DOMO15VXT	468	111,5	198	Rp2	13,6
DOMO20T	DOMO20VXT					

domo-2p50-en_c_td

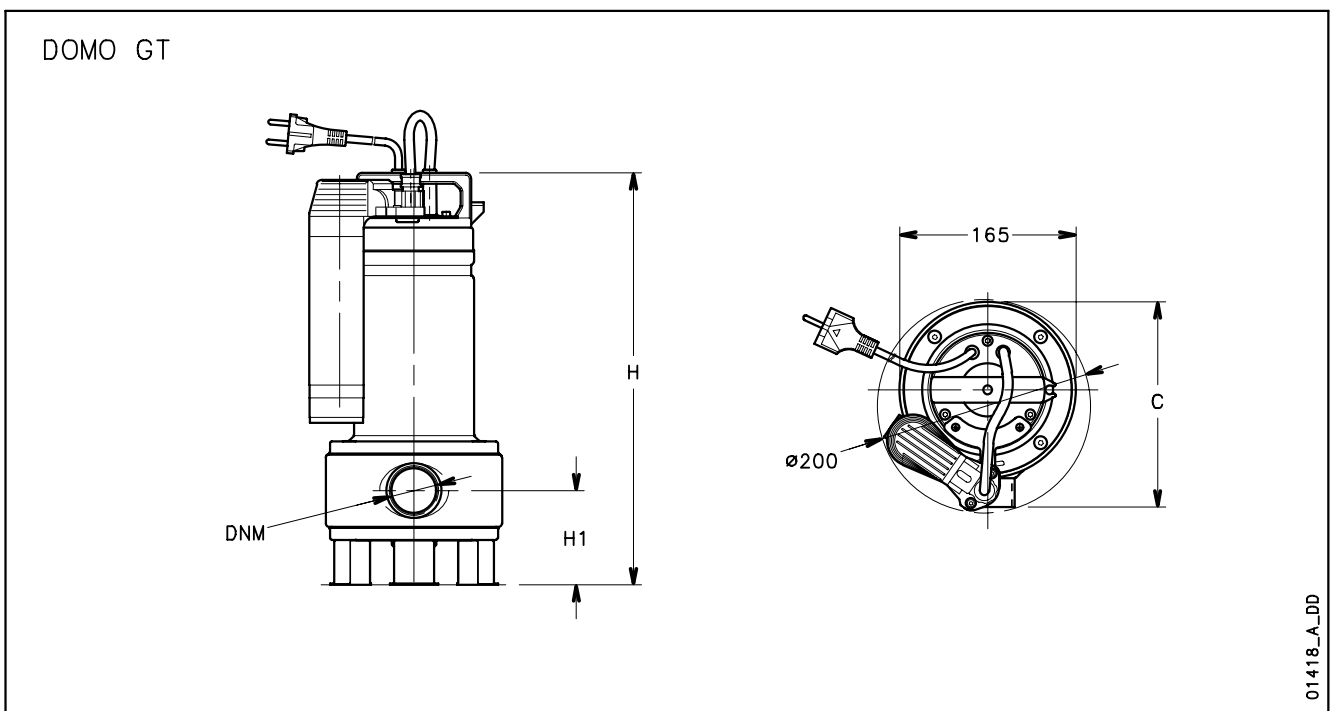



ITT

Lowara

DOMO - DOMO GRI SERIES INSTALLATION EXAMPLES

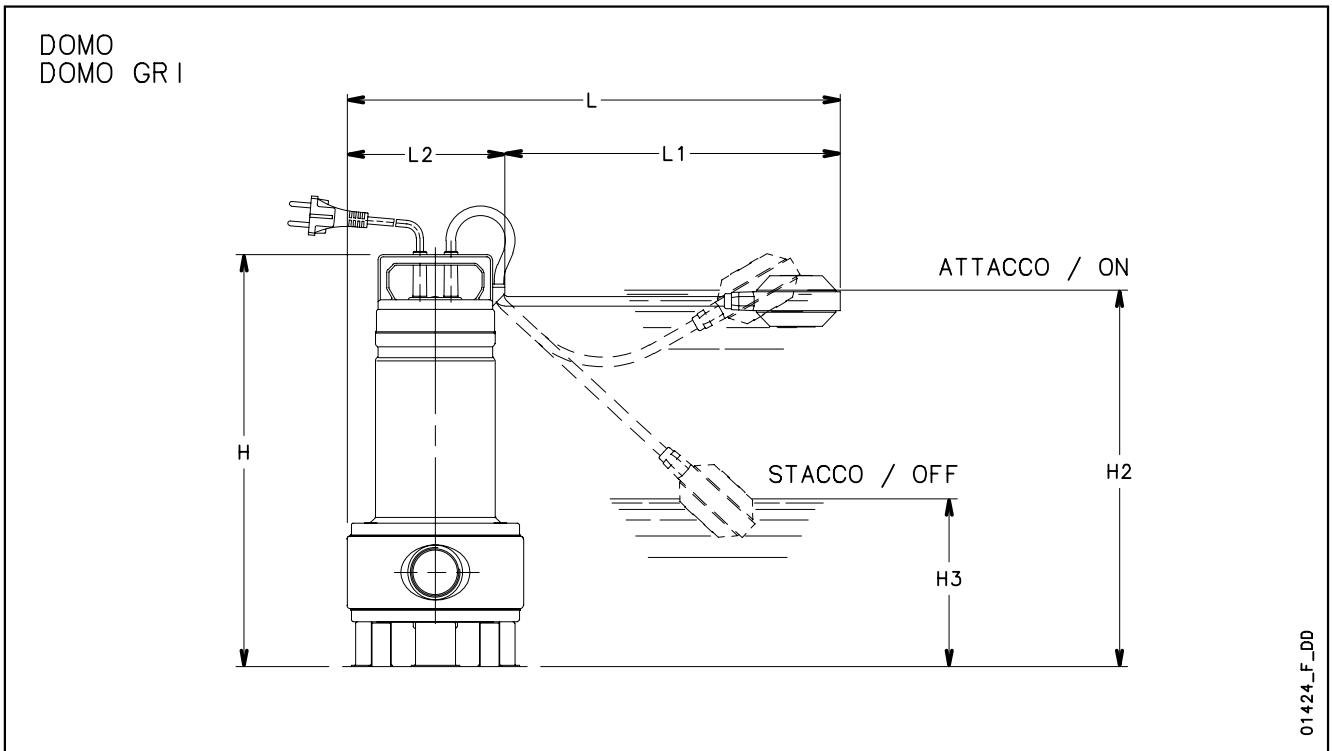

PUMP TYPE		DIMENSIONS (mm)						
		H	H2	H3	L	L1	L2	A
DOMO 7 - DOMO 7 GT	DOMO 7VX - DOMO 7VX GT	391	375	155	420	275	145	225
DOMO10 - DOMO10 GT	DOMO10VX - DOMO10VX GT	468	420	155	495	350	145	255
DOMO15 - DOMO15 GT	DOMO15VX - DOMO15VX GT	468	420	155	495	350	145	255
DOMO GRI 11	-	446	400	135	508	350	158	-

domoliv-2p50-en_d_td

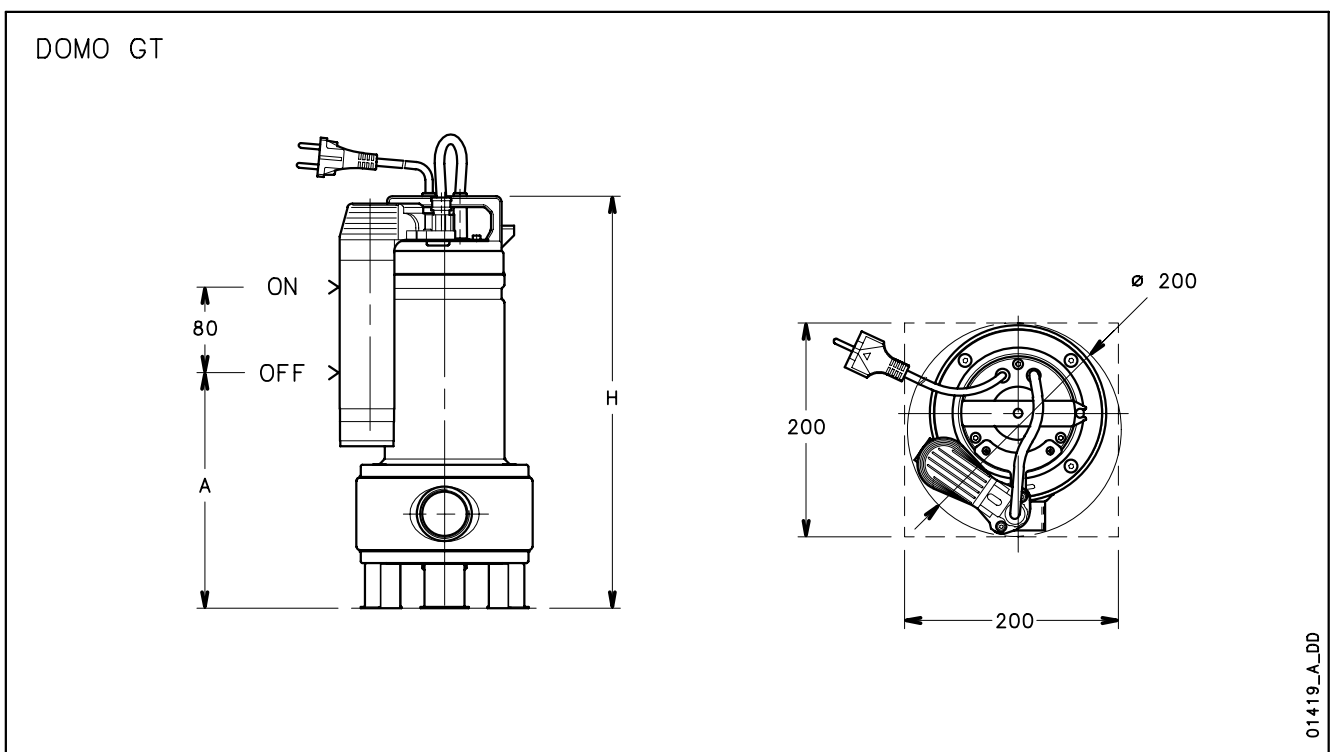



ITT

Lowara

DOMO GRI SERIES DIMENSIONS AND WEIGHTS

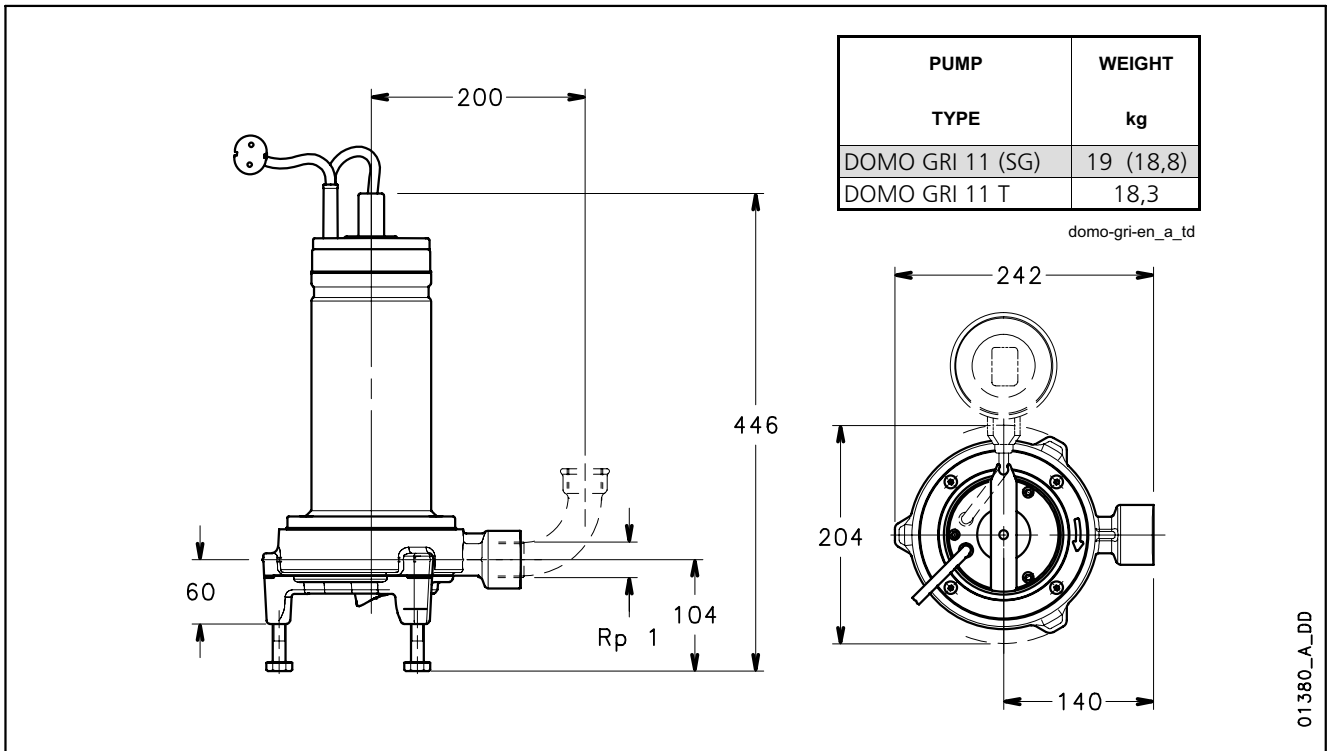

INSTALLATION WITH LIFTING AND LOWERING SYSTEM DEVICE

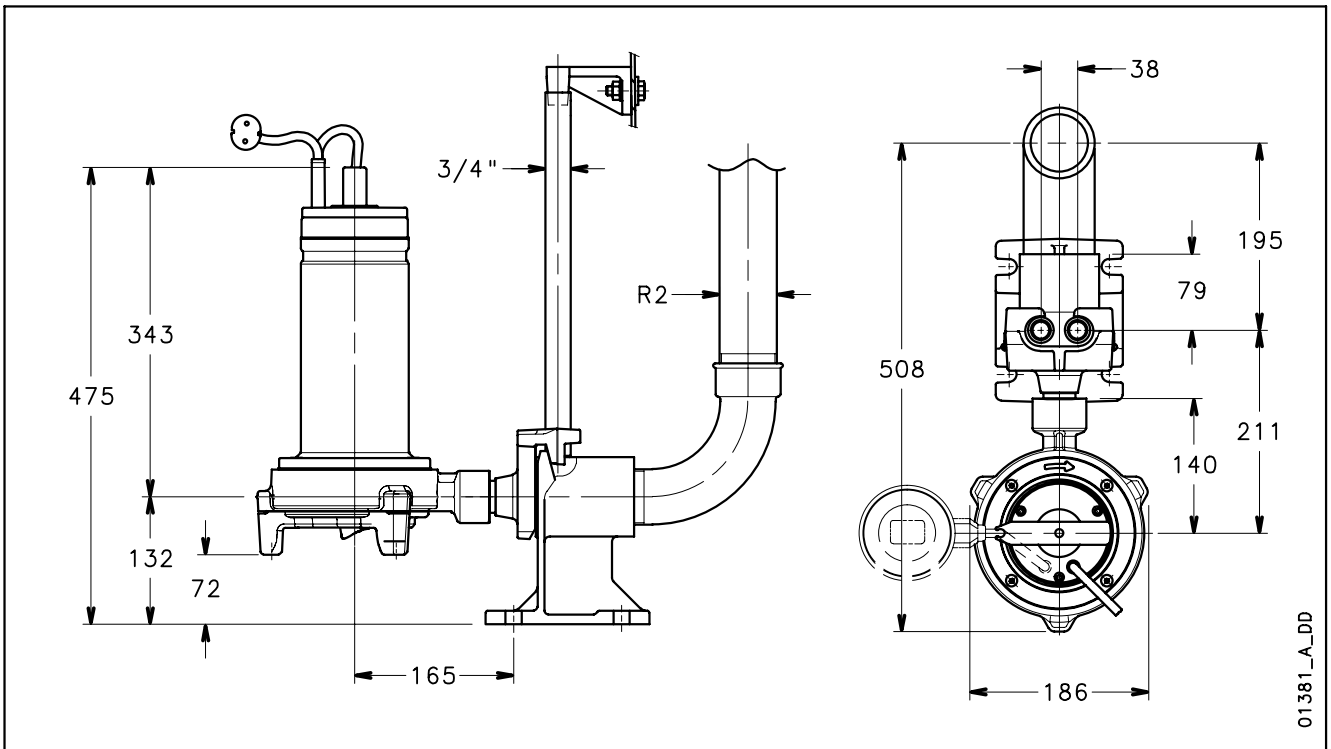

**Submersible
Electric Pumps
for clean and
slight dirty
water**

Drainage pumps with up to 22 metres head and up to 280 l/min (16,8 m³/h) delivery. This range consists of three pumps with up to 0,75 kW rated power.

DN Series



- **Mechanical seal** protected by **sand labyrinth**.
- Maximum **immersion depth: 5 m**.
- **Maximum liquid temperature: 50°C** with **fully submerged pump**.
25°C with **partially submerged pump**.
- **Versions:**
 - Single-phase: 220-240 V, 50 Hz
2 poles
with built-in automatic reset overload protection and capacitor housed in a control panel on the cable.
 - Three-phase: 220-240 V, 50 Hz
380-415 V, 50 Hz
2 poles.

Overload protection to provided by user and installed in the control panel. The control panel is available on request.
- **5 metres** of **H07RN-F** cable (the single-phase versions are also equipped with a control panel housing the capacitor + 1,5 m cord with plug).
- Motor insulation: class F.
- 60 Hz versions available on request.
- Pre-assembled float available on request (CG version).
- Clockwise rotation when looking at pump from above.

APPLICATIONS

- Draining of flooded excavations and marshy ground.
- Irrigation from rainwater resevoirs, ditches, ponds and watercourses.

SPECIFICATIONS

- Open **impeller** with **abrasion-resistant** rubber coating.
- Handles suspended solids up to 5 mm in diameter.
- Squirrel cage **motor** (2 poles - 2850 rpm) in a dielectric non-toxic **oil bath**, which ensures the lubrication of the ball bearings and more efficient cooling.

DN SERIES IDENTIFICATION CODE

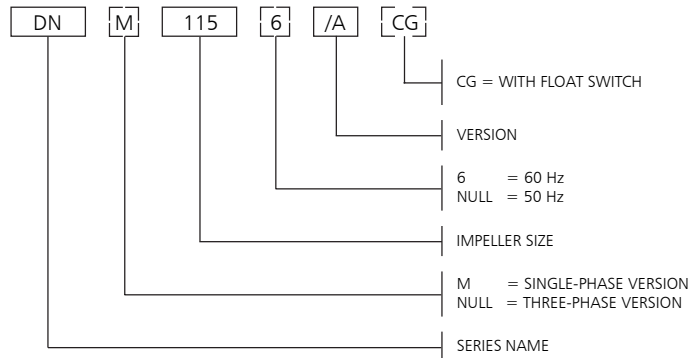

EXAMPLE : DNM 115/A
DN Series Electric pump, impeller size 115,
50 Hz version, single-phase, /A version.

SINGLE-PHASE RATING PLATE

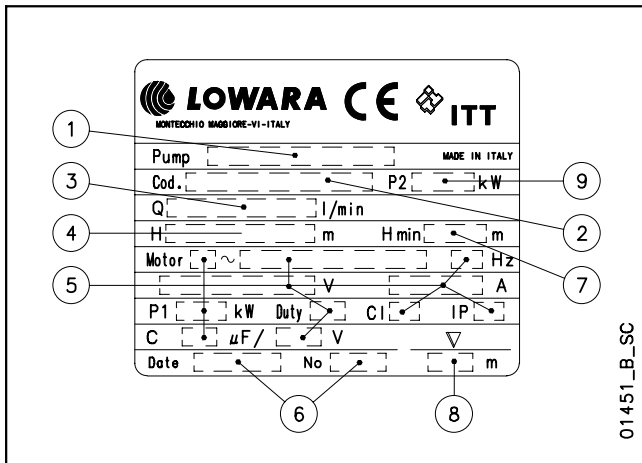

LEGEND

- 1 - Electric pump type
- 2 - Code
- 3 - Delivery range
- 4 - Head range
- 5 - Motor type
- 6 - Date of manufacture and serial number
- 7 - Minimum head
- 8 - Maximum immersion depth
- 9 - Rated output

THREE-PHASE RATING PLATE

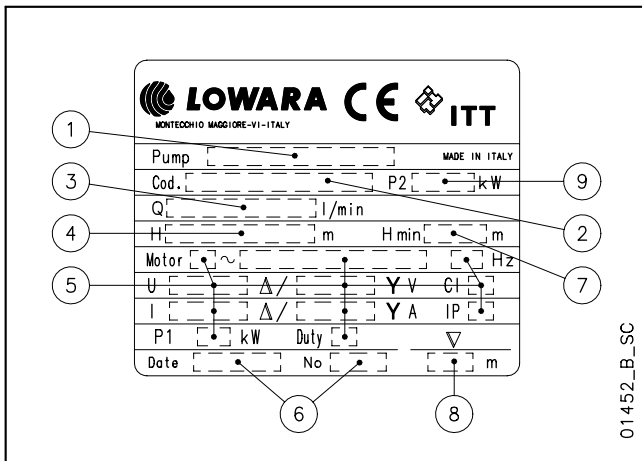

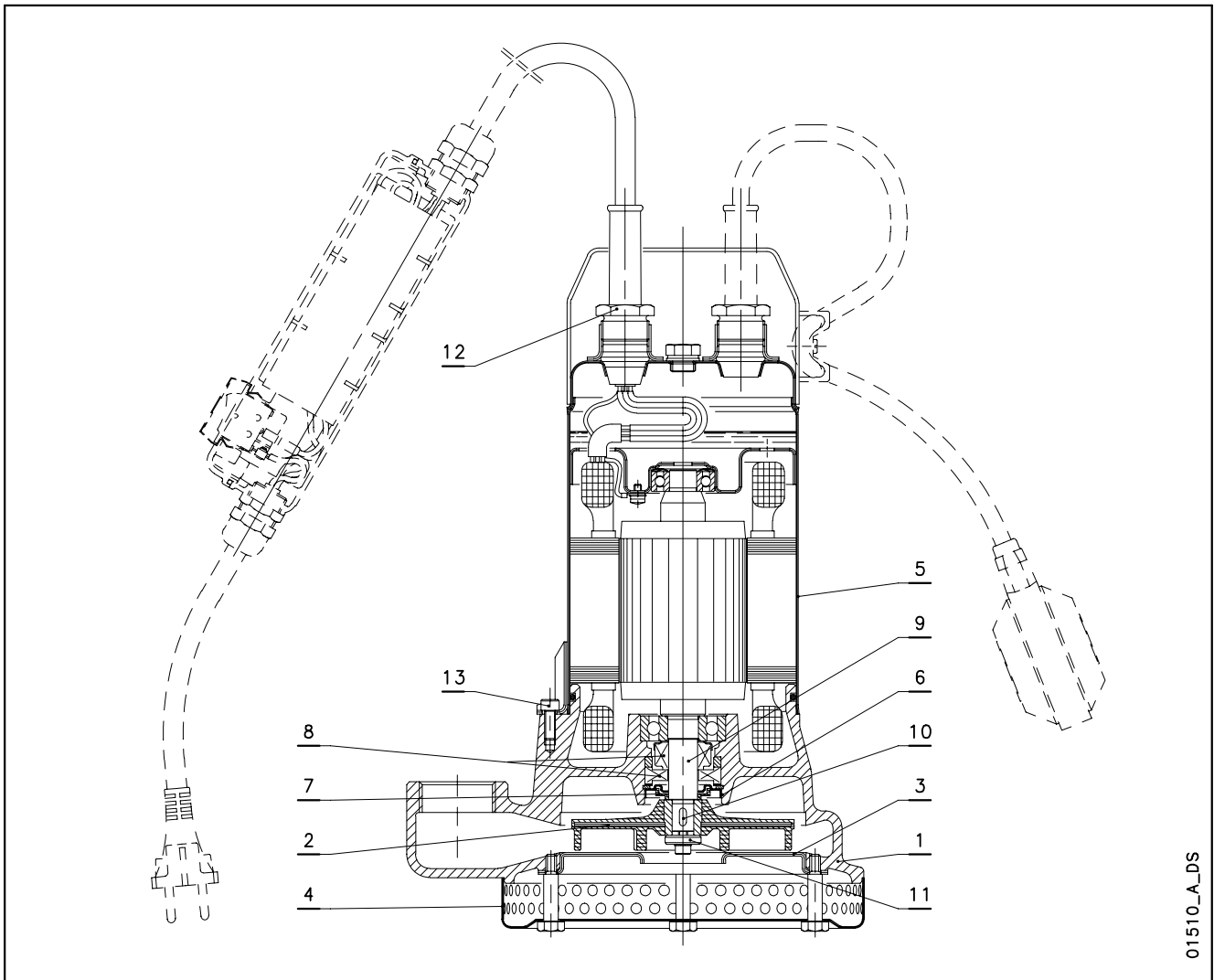
**DN SERIES
LIST OF MODELS AND TABLE OF MATERIALS**

01510_A_DS

REF. N.	NAME	MATERIAL	REFERENCE STANDARDS	
			EUROPE	USA
1	Pump body	Cast iron	EN 1561-GJL-200(JL1030)	ASTM Class 25
2	Impeller	Steel + Nitrile Rubber XNBR		
3	Wearing flange	Stainless steel	EN 10088-1-X5CrNi18-10 (1.4301)	AISI 304
4	Suction strainer	Stainless steel	EN 10088-1-X5CrNi18-10 (1.4301)	AISI 304
5	Motor casing	Stainless steel	EN 10088-1-X5CrNi18-10 (1.4301)	AISI 304
6	Labyrinth cover	Stainless steel	EN 10088-1-X5CrNi18-10 (1.4301)	AISI 304
7	Labyrinth insert	NBR (standard version)		
8	Mechanical seal	Carbon / Ceramic Alumina / NBR (standard version)		
9	Shaft end	Stainless steel	EN 10088-1-X5CrNi18-10 (1.4301)	AISI 304
10	Key	Stainless steel	EN 10088-1-X5CrNiMo17-12-2 (1.4401)	AISI 316
11	Washer	Stainless steel		AISI 303
12	Cable gland	Brass		
13	Screws	Stainless steel	EN 10088-1-X5CrNi18-10 (1.4301)	AISI 304

dn-en_b_tm

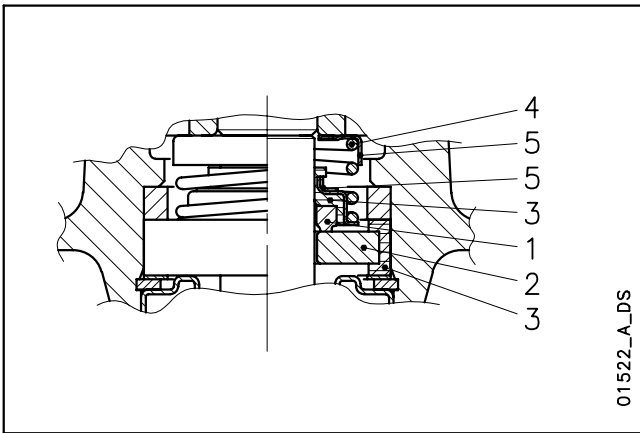
**DN SERIES
MECHANICAL SEAL**

LIST OF MATERIALS

POSITION 1 - 2	POSITION 3	POSITION 4 - 5
B : Carbon	P : NBR	F : AISI 304
V : Ceramic Alumina	V : FPM	
U ₃ : Tungsten Carbide		

dn-dl-dlv_ten-mec-en_b_tm

SEAL TYPES

TYPE	POSITION					TEMPERATURE (°C)
	1 ROTATING ASSEMBLY	2 FIXED ASSEMBLY	3 ELASTOMERS	4 SPRINGS	5 OTHER COMPONENTS	
STANDARD MECHANICAL SEAL						
BVPFF	B	V	P	F	F	-5 +50
OTHER MECHANICAL SEAL TYPES						
U ₃ U ₃ VFF	U ₃	U ₃	V	F	F	-5 +50

dn-dl-dlv_tipi-ten-mec-en_a_tc



ITT

Lowara

DN SERIES OPERATING CHARACTERISTICS AT 50 Hz

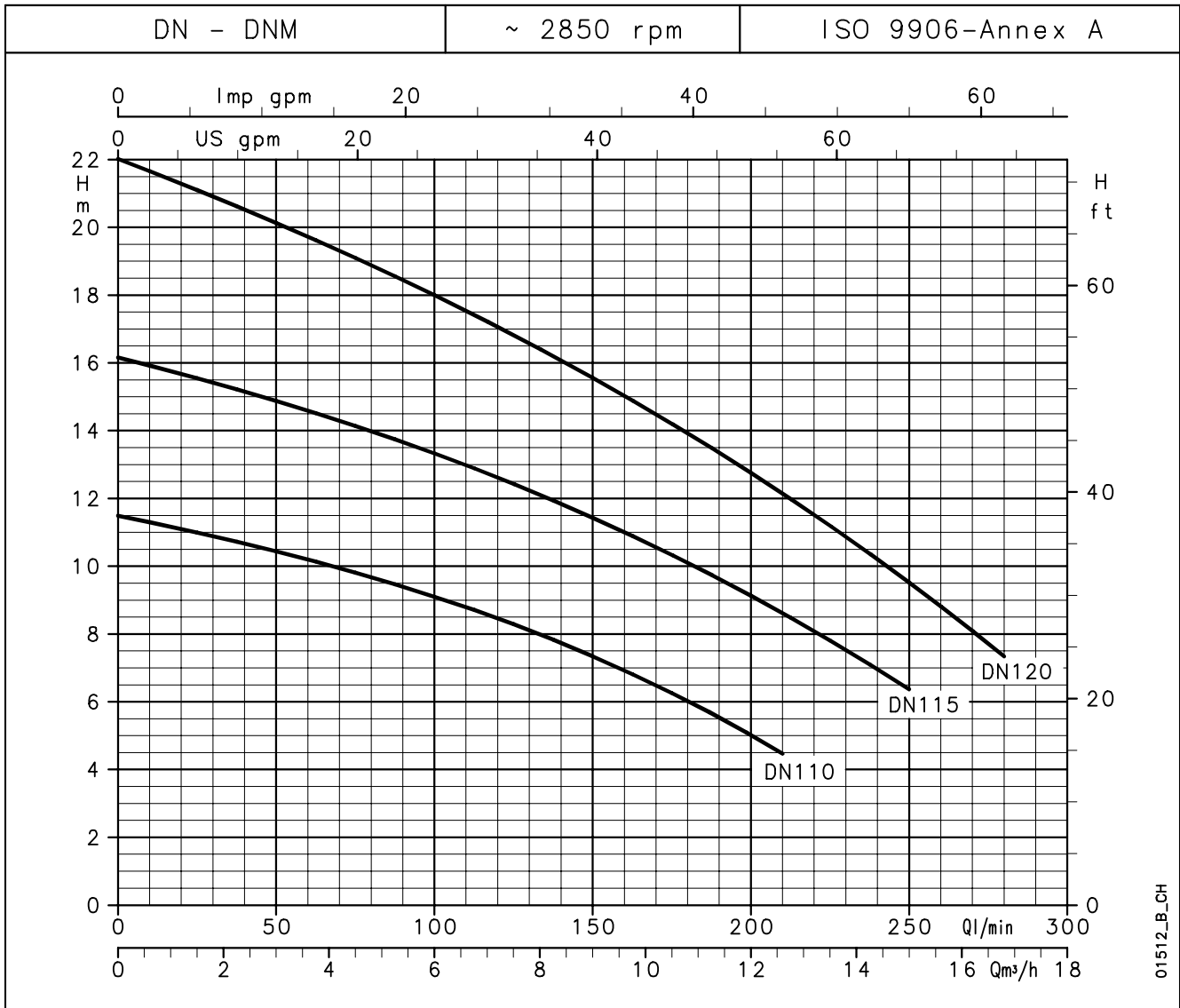

HYDRAULIC PERFORMANCE TABLE

PUMP TYPE	RATED POWER		Q = DELIVERY												
			l/min	0	25	50	75	100	125	150	175	210	225	250	280
			m³/h	0	1,5	3	4,5	6	7,5	9	10,5	12,6	13,5	15	16,8
			H = TOTAL HEAD METRES COLUMN OF WATER												
DN(M) 110	0,6	0,8	11,5	11,0	10,4	9,8	9,1	8,3	7,3	6,3	4,5				
DN(M) 115	0,6	0,8	16,2	15,6	14,9	14,1	13,3	12,4	11,4	10,3	8,6	7,8	6,4		
DN(M) 120	0,75	1	22,0	21,1	20,1	19,1	18,0	16,8	15,6	14,2	12,1	11,2	9,5	7,3	

These performances are valid for liquids with density $\rho = 1,0 \text{ kg/dm}^3$ and kinematic viscosity $\nu = 1 \text{ mm}^2/\text{s}$.

dn-2p50-en_a_th

ELECTRICAL DATA TABLE

PUMP TYPE	ABSORBED POWER*	ABSORBED CURRENT*	CAPACITOR
SINGLE-PHASE	kW	220-240 V A	$\mu\text{F} / 450 \text{ V}$
DNM 110	0,68	3,56	25
DNM 115	0,90	4,28	25
DNM 120	1,03	4,77	25

PUMP TYPE	ABSORBED POWER*	ABSORBED CURRENT*	ABSORBED CURRENT*
THREE-PHASE	kW	220-240 V A	380-415 V A
DN 110	0,66	3,46	2,00
DN 115	0,93	3,81	2,20
DN 120	1,09	4,05	2,34

*Maximum values within operating range.

dn-2p50-en_b_te



ITT

Lowara

DN SERIES DIMENSIONS AND WEIGHTS

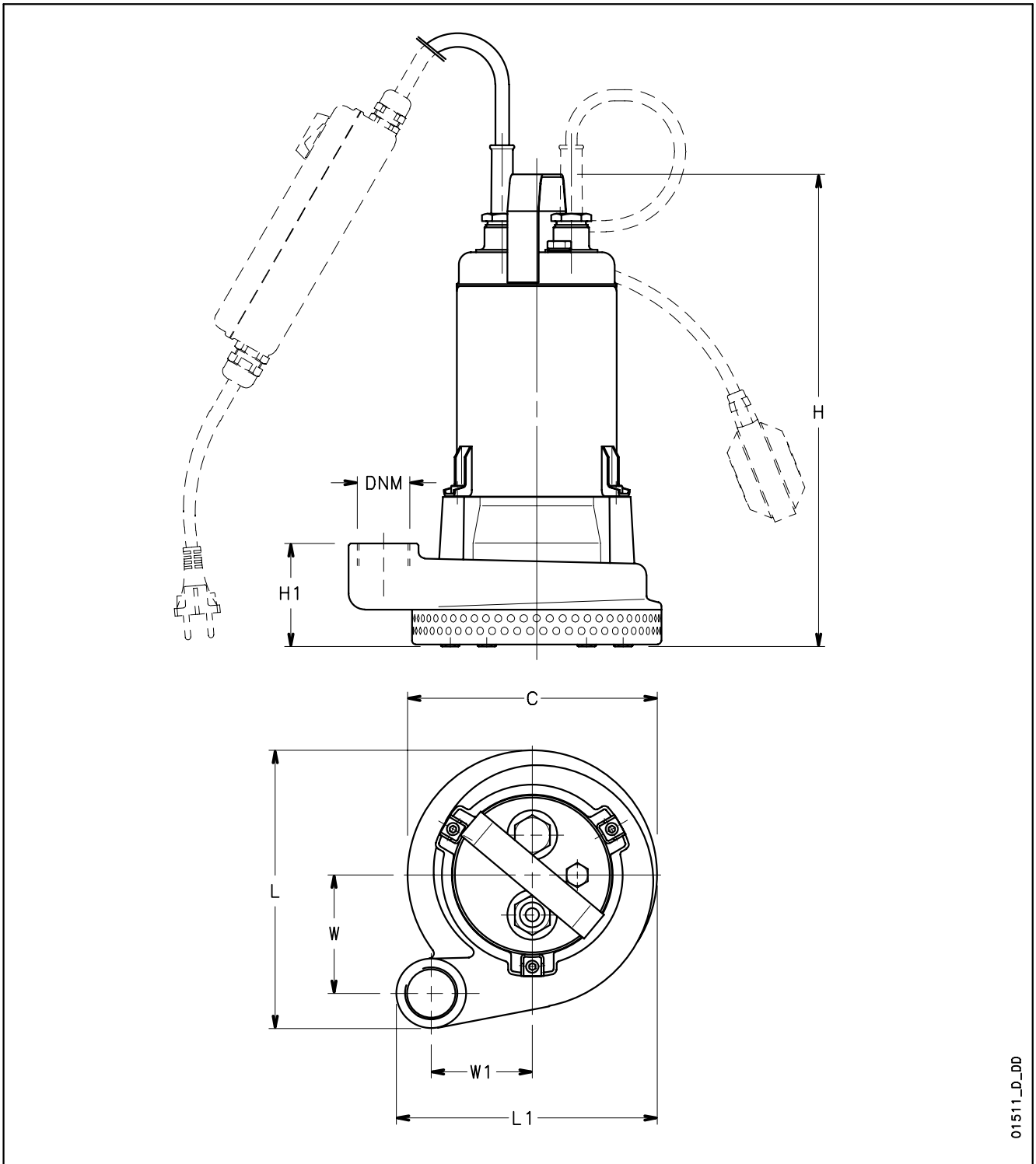

01511_D_DD

PUMP TYPE	DIMENSIONS (mm)							DNM	WEIGHT kg
	C	H	H1	L	L1	W	W1		
DNM110-DN110	Ø 200	380	81	223	209	95	81	Rp 1¼	18,5
DNM115-DN115	Ø 200	380	81	223	209	95	81	Rp 1¼	18,5
DNM120-DN120	Ø 200	380	81	223	209	95	81	Rp 1¼	19,5

dn-2p50-en_b_td



ITT

Lowara

Submersible Electric Pumps for pumping sewage

The DL series electric pumps come with single-channel or Vortex impeller (DLV), and are designed to handle solids-laden wastewater, with up to 22 m head and 42 m³/h delivery. 0,6 kW to 1,5 kW rated power. Solid handled up to 50 mm in diameter.

DL Series



- Motor insulation: class F.
- **2 pole** (0,6 to 1,5 kW) motor.
- **Mechanical seal** protected by **sand labyrinth**.
- **Versions:**
 - Single-phase: 220-240 V, 50 Hz
2 poles
with built-in thermal protector and capacitor box with on/off switch.
 - Three-phase: 220-240 V, 50 Hz
380-415 V, 50 Hz
2 poles.
- Overload protection to provided by user (in the control panel).
- **5 metres** of **H07RN-F** cable (the single-phase versions are also equipped with a control panel housing the capacitor + 1,5 m cord with plug).
- 60 Hz versions available on request.
- Pre-assembled float available on request (DL...CG, DLV...CG).

APPLICATIONS

- Pumping of sewage with suspended solids and filaments.
- Emptying of sumps, septic tanks and wastewater discharge tanks.
- Draining of flooded excavations and marshy ground.

SPECIFICATIONS

- Maximum **immersion depth: 5 m.**
- **Maximum liquid temperature: 50°C** with **fully submerged pump.**
25°C with **partially submerged pump.**
- **Passes solids** up to:
45 mm (DL 80, 90, 105 Minivortex, Vortex).
50 mm (DL 109, 125 DLV 100, 115).
- Squirrel cage **motor** in a dielectric non-toxic **oil bath**, which ensures the lubrication of the ball bearings and more efficient cooling.



ITT

Lowara

DL - DLV SERIES IDENTIFICATION CODE

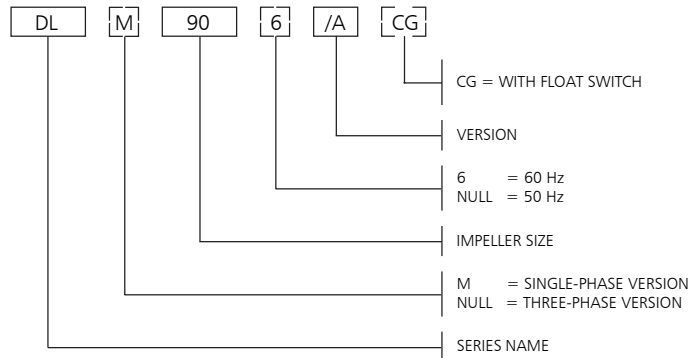

EXAMPLE : DLM 90/A
DL Series electric pump, impeller size 90,
50 Hz version, single-phase, /A version.

SINGLE-PHASE RATING PLATE

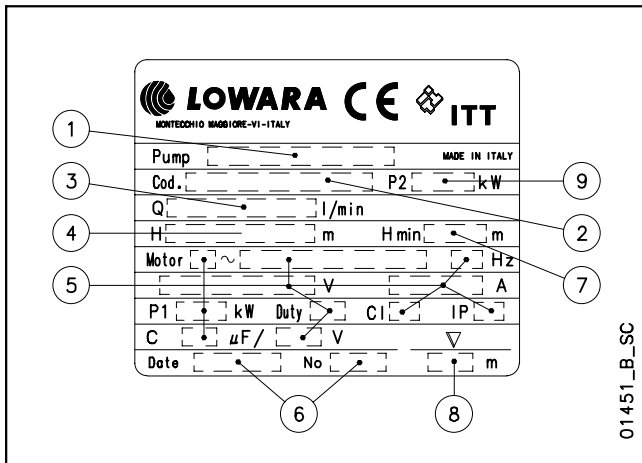

LEGEND

- 1 - Electric pump type
- 2 - Code
- 3 - Delivery range
- 4 - Head range
- 5 - Motor type
- 6 - Date of manufacture and serial number
- 7 - Minimum head
- 8 - Maximum immersion depth
- 9 - Rated output

THREE-PHASE RATING PLATE

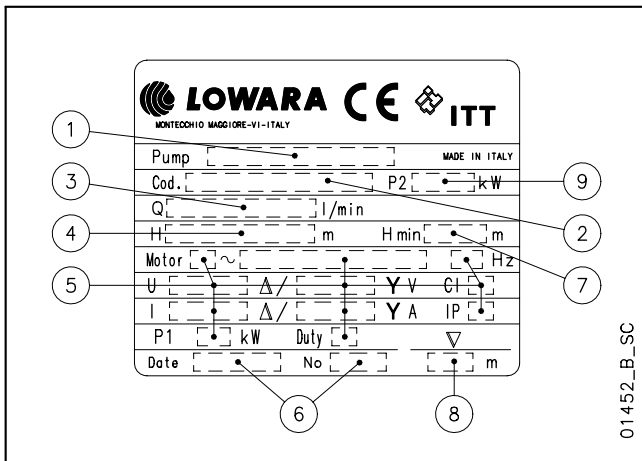

DL-VORTEX SERIES LIST OF MODELS AND TABLE OF MATERIALS

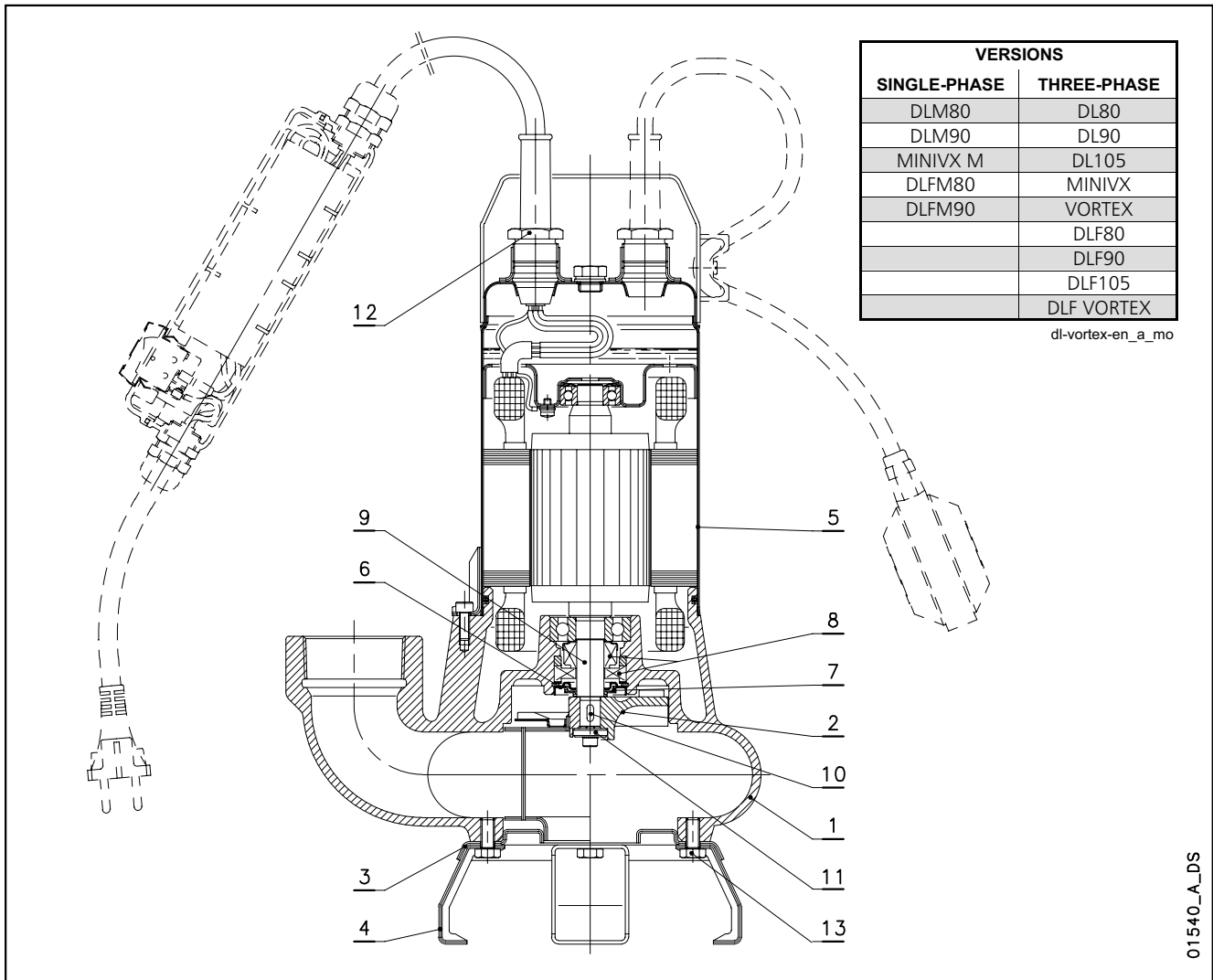

01540_A_DS

REF. N.	NAME	MATERIAL	REFERENCE STANDARDS	
			EUROPE	USA
1	Pump body	Cast iron	EN 1561-GJL-200(JL1030)	ASTM Class 25
2	Vortex impeller	Cast iron	EN 1561-GJL-200(JL1030)	ASTM Class 25
	Single-channel impeller	Stainless steel	EN 10088-1-X5CrNi18-10 (1.4301)	AISI 304
3	Suction flange	Stainless steel	EN 10088-1-X5CrNi18-10 (1.4301)	AISI 304
4	Support foot	Stainless steel	EN 10088-1-X5CrNi18-10 (1.4301)	AISI 304
5	Motor casing	Stainless steel	EN 10088-1-X5CrNi18-10 (1.4301)	AISI 304
6	Labyrinth cover	Stainless steel	EN 10088-1-X5CrNi18-10 (1.4301)	AISI 304
7	Labyrinth insert	NBR (standard version)		
8	Mechanical seal	Carbon / Ceramic Alumina / NBR (standard version)		
9	Shaft end	Stainless steel	EN 10088-1-X5CrNi18-10 (1.4301)	AISI 304
10	Key	Stainless steel	EN 10088-1-X5CrNiMo17-12-2 (1.4401)	AISI 316
11	Washer	Stainless steel		AISI 303
12	Cable gland	Brass		
13	Screws	Stainless steel	EN 10088-1-X5CrNi18-10 (1.4301)	AISI 304

dl-vortex-en_b_tm



ITT

Lowara

DL-DLV SERIES LIST OF MODELS AND TABLE OF MATERIALS

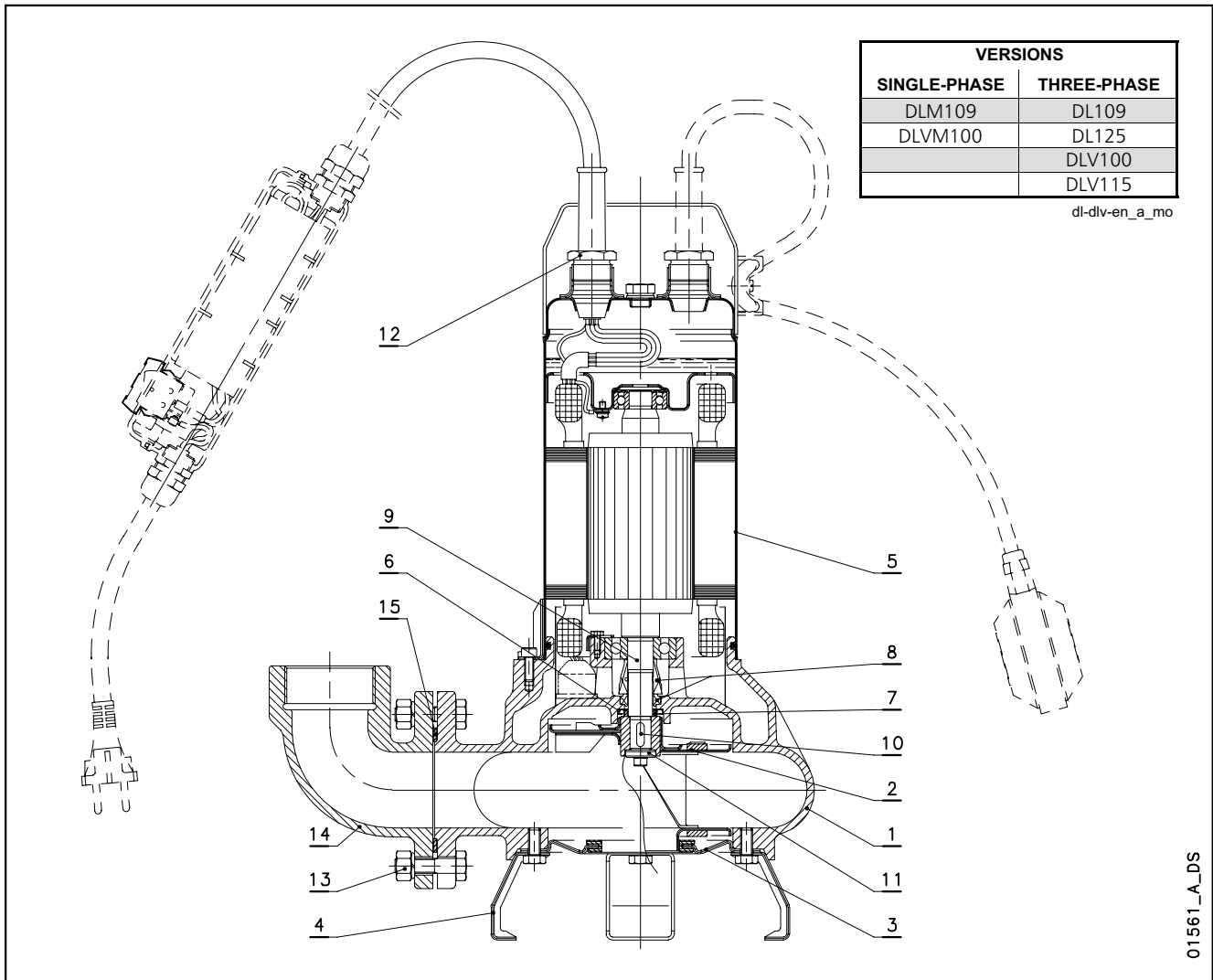

01561_A_DS

REF. N.	NAME	MATERIAL	REFERENCE STANDARDS	
			EUROPE	USA
1	Pump body	Cast iron	EN 1561-GJL-200(JL1030)	ASTM Class 25
2	Vortex impeller	Stainless steel	EN 10088-1-X5CrNi18-10 (1.4301)	AISI 304
	Single-channel impeller	Stainless steel	EN 10088-1-X5CrNi18-10 (1.4301)	AISI 304
3	Suction flange	Stainless steel	EN 10088-1-X5CrNi18-10 (1.4301)	AISI 304
4	Support foot	Stainless steel	EN 10088-1-X5CrNi18-10 (1.4301)	AISI 304
5	Motor casing	Stainless steel	EN 10088-1-X5CrNi18-10 (1.4301)	AISI 304
6	V-RING Cover	Stainless steel	EN 10088-1-X5CrNi18-10 (1.4301)	AISI 304
7	V16A Seal ring	NBR (standard version)		
8	Mechanical seal	Carbon / Ceramic Alumina / NBR (standard version)		
9	Shaft end	Stainless steel	EN 10088-1-X5CrNi18-10 (1.4301)	AISI 304
10	Key	Stainless steel	EN 10088-1-X5CrNiMo17-12-2 (1.4401)	AISI 316
11	Washer	Stainless steel		AISI 303
12	Cable gland	Brass		
13	Screws	Stainless steel	EN 10088-1-X5CrNi18-10 (1.4301)	AISI 304
14	Delivery connection	Cast iron	EN 1561-GJL-200(JL1030)	ASTM Class 25
15	Delivery connection gasket	Nitrile rubber		

dl-dlv-en_b_tm



ITT

Lowara

**DL80-90-105 - MINIVORTEX-VORTEX SERIES
MECHANICAL SEAL**

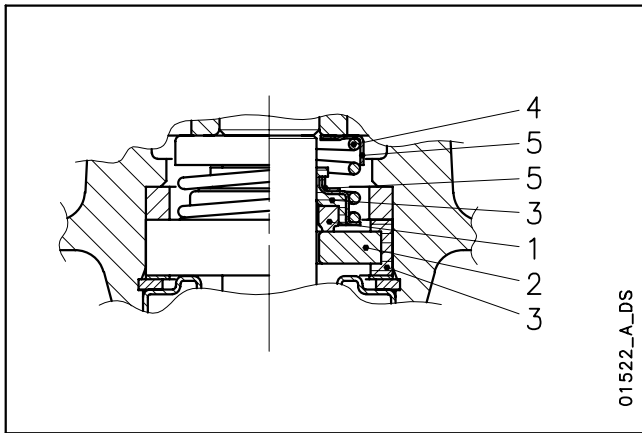

01522_A_DS

LIST OF MATERIALS

POSITION 1 - 2	POSITION 3	POSITION 4 - 5
B : Carbon	P : NBR	F : AISI 304
V : Ceramic Alumina	V : FPM	
U ₃ : Tungsten Carbide		

dn-dl-dlv_ten-mec-en_b_tm

SEAL TYPES

TYPE	POSITION					TEMPERATURE (°C)
	1 ROTATING ASSEMBLY	2 FIXED ASSEMBLY	3 ELASTOMERS	4 SPRINGS	5 OTHER COMPONENTS	
STANDARD MECHANICAL SEAL						
BVPFF	B	V	P	F	F	-5 +50
OTHER MECHANICAL SEAL TYPES						
U ₃ U ₃ VFF	U ₃	U ₃	V	F	F	-5 +50

dn-dl-dlv_tipi-ten-mec-en_a_tc



ITT

Lowara

**DL109-125 - DLV100-115 SERIES
MECHANICAL SEAL**

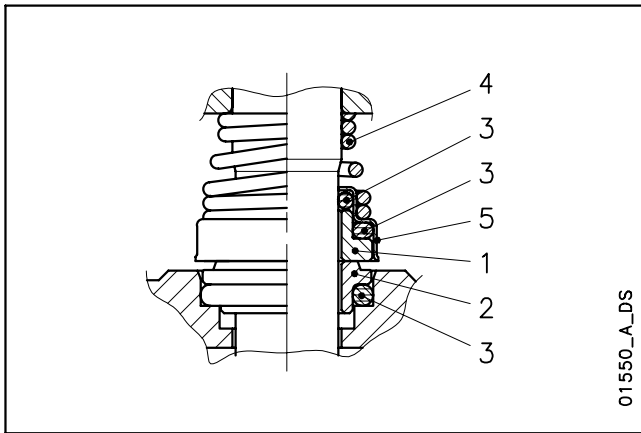

LIST OF MATERIALS

POSITION 1 - 2	POSITION 3	POSITION 4 - 5
B : Carbon	P : NBR	G : AISI 316
U₃ : Tungsten Carbide	V : FPM	F : AISI 304
V : Ceramic Alumina		

dl-dlv_ten-mec-en_a_tm

SEAL TYPES

TYPE	POSITION					TEMPERATURE (°C)
	1 ROTATING ASSEMBLY	2 FIXED ASSEMBLY	3 ELASTOMERS	4 SPRINGS	5 OTHER COMPONENTS	
STANDARD MECHANICAL SEAL						
VBPGF	V	B	P	G	F	-5 +50
OTHER MECHANICAL SEAL TYPES						
U ₃ U ₃ VFF	U ₃	U ₃	V	F	F	-5 +50

dl-dlv_tipi-ten-mec-en_a_tc



ITT

Lowara

DL SERIES OPERATING CHARACTERISTICS AT 50 Hz

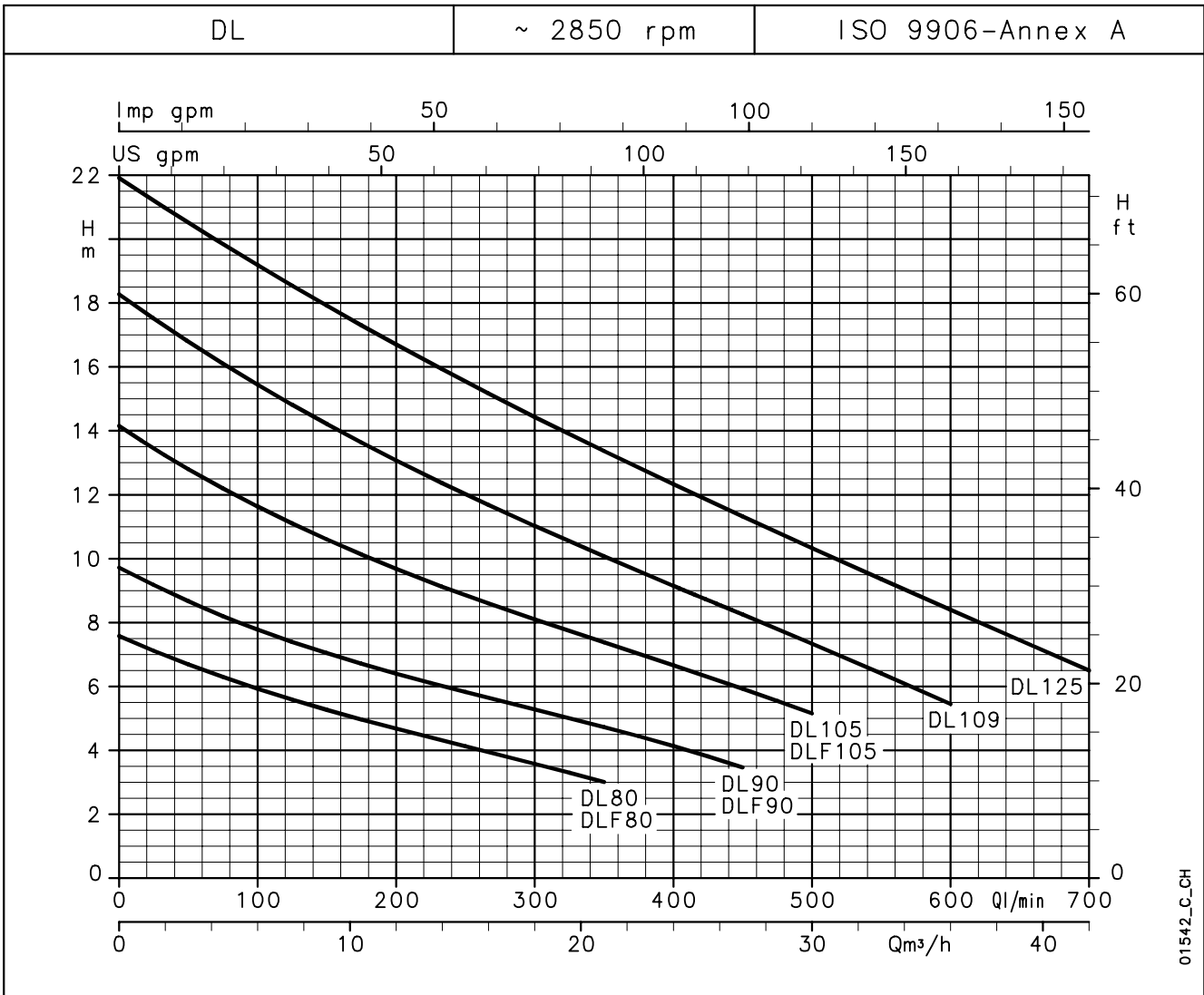

01542_C_CH

HYDRAULIC PERFORMANCE TABLE

PUMP TYPE	RATED POWER		Q = DELIVERY												
			l/min	0	100	150	200	250	300	350	400	450	500	600	700
			m³/h	0	6	9	12	15	18	21	24	27	30	36	42
H = TOTAL HEAD METRES COLUMN OF WATER															
DL(M) 80-DLF(M) 80	0,6	0,8	7,6	5,9	5,3	4,7	4,1	3,6	3,0						
DL(M) 90-DLF(M) 90	0,6	0,8	9,7	7,8	7,0	6,4	5,8	5,3	4,7	4,1	3,5				
DL 105 - DLF105	1,1	1,5	14,1	11,6	10,6	9,7	8,9	8,1	7,4	6,7	5,9	5,2			
DL(M) 109	1,1	1,5	18,3	15,4	14,2	13,1	12,0	11,0	10,1	9,2	8,2	7,3	5,4		
DL 125	1,5	2	21,9	19,2	17,9	16,7	15,5	14,4	13,4	12,3	11,3	10,3	8,4	6,5	

These performances are valid for liquids with density $\rho = 1,0 \text{ kg/dm}^3$ and kinematic viscosity $\nu = 1 \text{ mm}^2/\text{s}$.

dl-2p50-en_b_th

ELECTRICAL DATA TABLE

PUMP TYPE	ABSORBED POWER*	ABSORBED CURRENT*	CAPACITOR
	kW	A	$\mu\text{F} / 450 \text{ V}$
SINGLE-PHASE			
DLM80-DLFM80	0,79	3,91	25
DLM90-DLFM90	0,89	4,27	25
-	-	-	-
DLM109	1,55	6,87	35
-	-	-	-

PUMP TYPE	ABSORBED POWER*	ABSORBED CURRENT*	ABSORBED CURRENT*
	kW	A	A
THREE-PHASE			
DL80-DLF80	0,8	-	2,09
DL90-DLF90	0,92	3,81	2,2
DL105-DLF105	1,43	4,66	2,69
DL109	1,54	5,44	3,14
DL125	2,14	6,58	3,8

*Maximum values within operating range.

dl-2p50-en_b_te

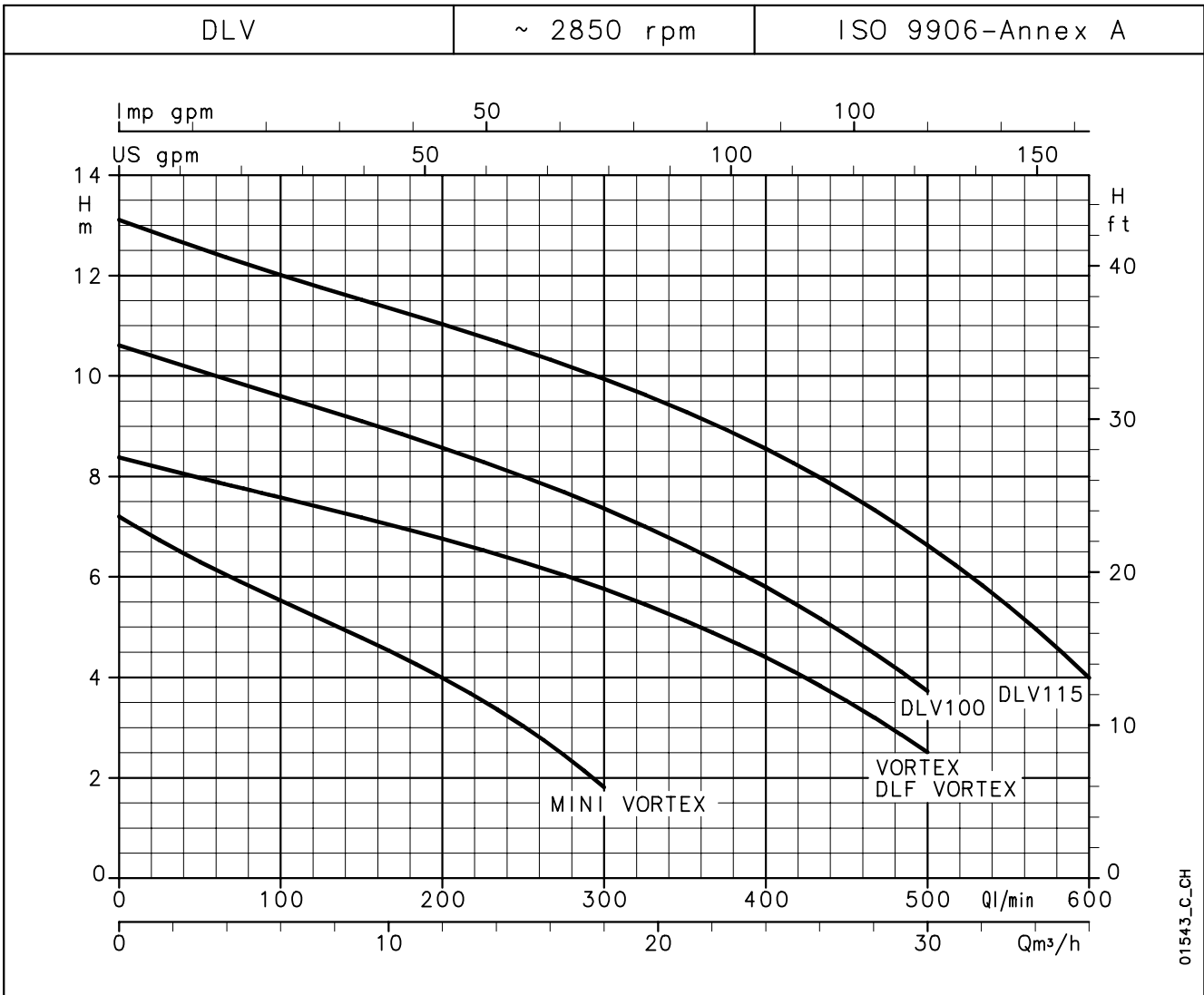
**DLV SERIES
OPERATING CHARACTERISTICS AT 50 Hz**

HYDRAULIC PERFORMANCE TABLE

PUMP TYPE	RATED POWER		Q = DELIVERY												
			l/min	0	50	100	150	200	250	300	350	400	450	500	600
			m ³ /h	0	3	6	9	12	15	18	21	24	27	30	36
	kW	HP	H = TOTAL HEAD METRES COLUMN OF WATER												
MINI VORTEX(M)	0,6	0,8	7,2	6,3	5,5	4,8	4,0	3,0	1,8						
VORTEX-DLF VORTEX	1,1	1,5	8,4	8,0	7,6	7,2	6,8	6,3	5,8	5,1	4,4	3,5	2,5		
DLV(M) 100	1,1	1,5	10,6	10,1	9,6	9,1	8,6	8,0	7,4	6,6	5,8	4,8	3,7		
DLV 115	1,5	2	13,1	12,5	12,0	11,5	11,0	10,5	9,9	9,3	8,5	7,7	6,6	4,0	

These performances are valid for liquids with density $\rho = 1,0 \text{ kg/dm}^3$ and kinematic viscosity $\nu = 1 \text{ mm}^2/\text{s}$.

dlv-2p50-en_b_th

ELECTRICAL DATA TABLE

PUMP TYPE	ABSORBED POWER*	ABSORBED CURRENT*	CAPACITOR
SINGLE-PHASE	kW	220-240 V A	$\mu\text{F} / 450 \text{ V}$
MINI VORTEX M	1,05	4,82	25
-	-	-	-
DLVM100	1,64	7,30	35
-	-	-	-

PUMP TYPE	ABSORBED POWER*	ABSORBED CURRENT*	ABSORBED CURRENT*
THREE-PHASE	kW	220-240 V A	380-415 V A
MINI VORTEX	1,10	-	2,36
VORTEX-DLF VORTEX	1,66	5,11	2,95
DLV 100	1,65	5,63	3,25
DLV 115	2,25	6,81	3,93

*Maximum values within operating range.

dlv-2p50-en_b_te



ITT

Lowara

**DL - VORTEX SERIES
DIMENSIONS AND WEIGHTS**

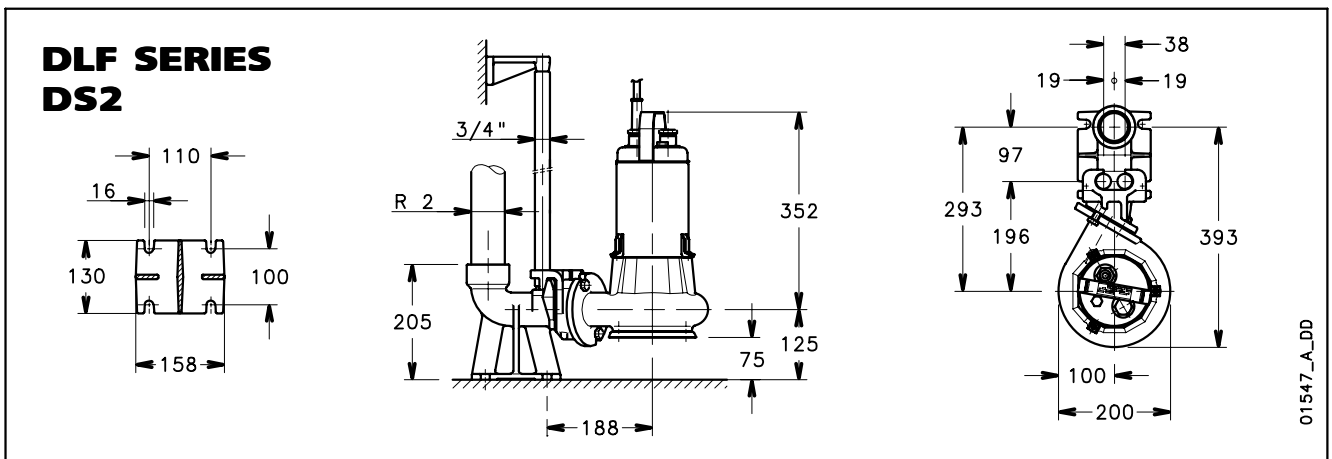
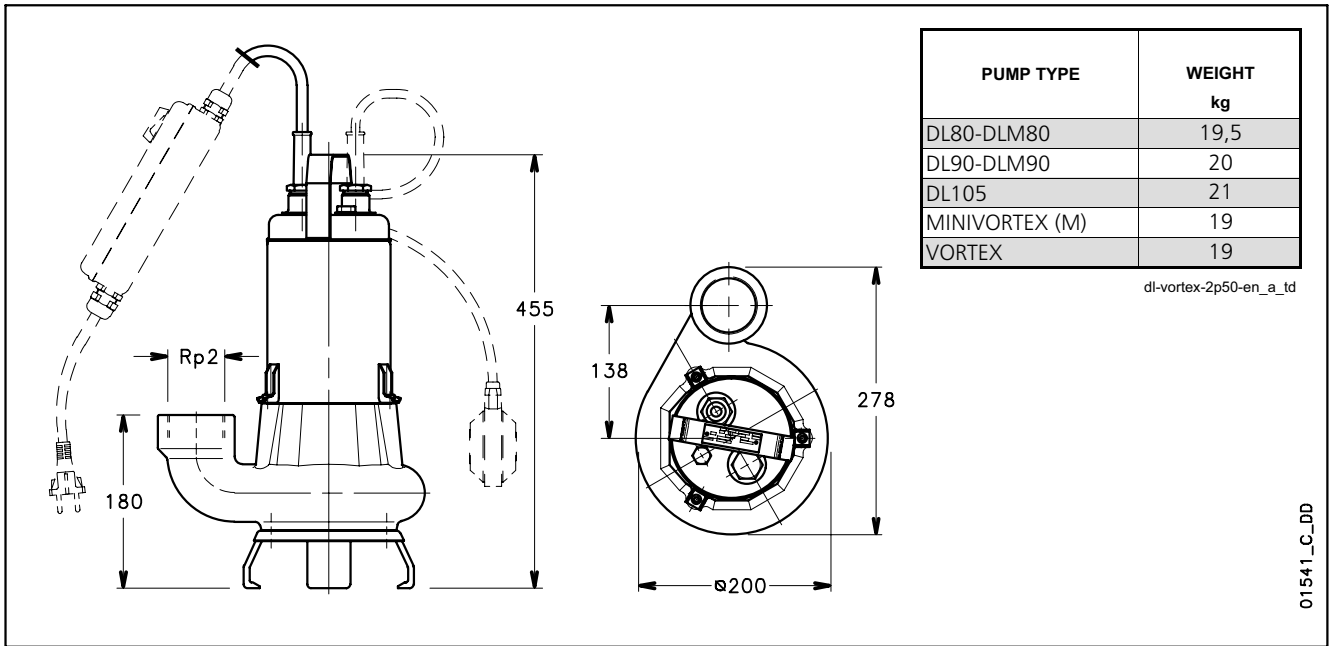



ITT

Lowara

DL - DLV SERIES DIMENSIONS AND WEIGHTS

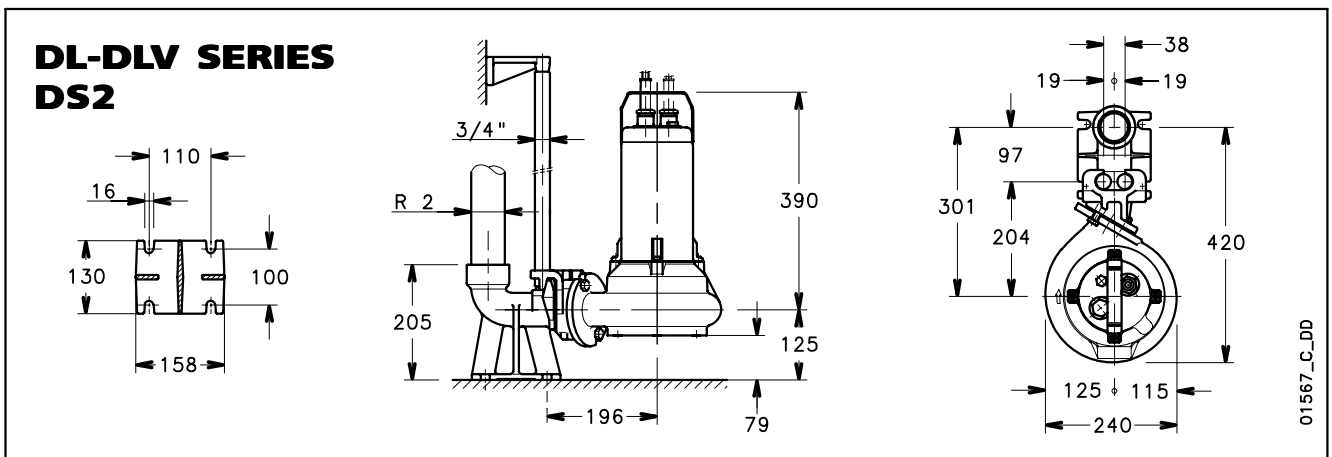
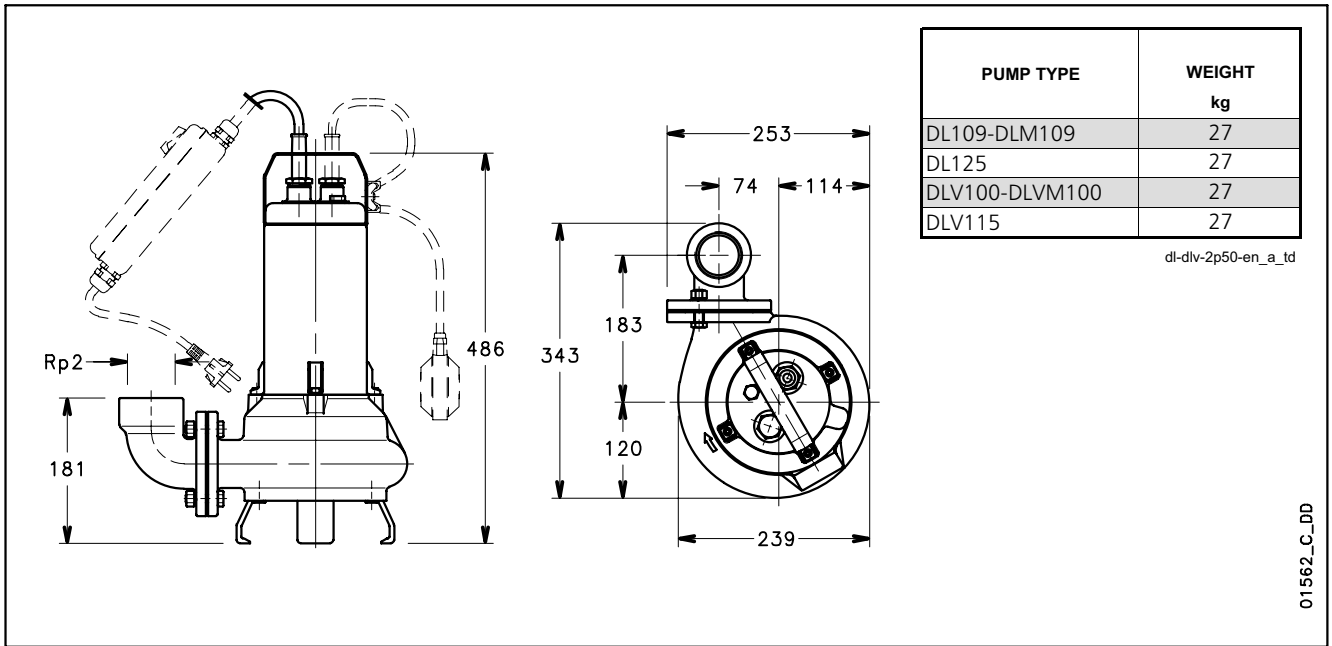



ITT

Lowara

TECHNICAL APPENDIX



EXAMPLE OF INSTALLATION OF SINGLE-PUMP SYSTEM

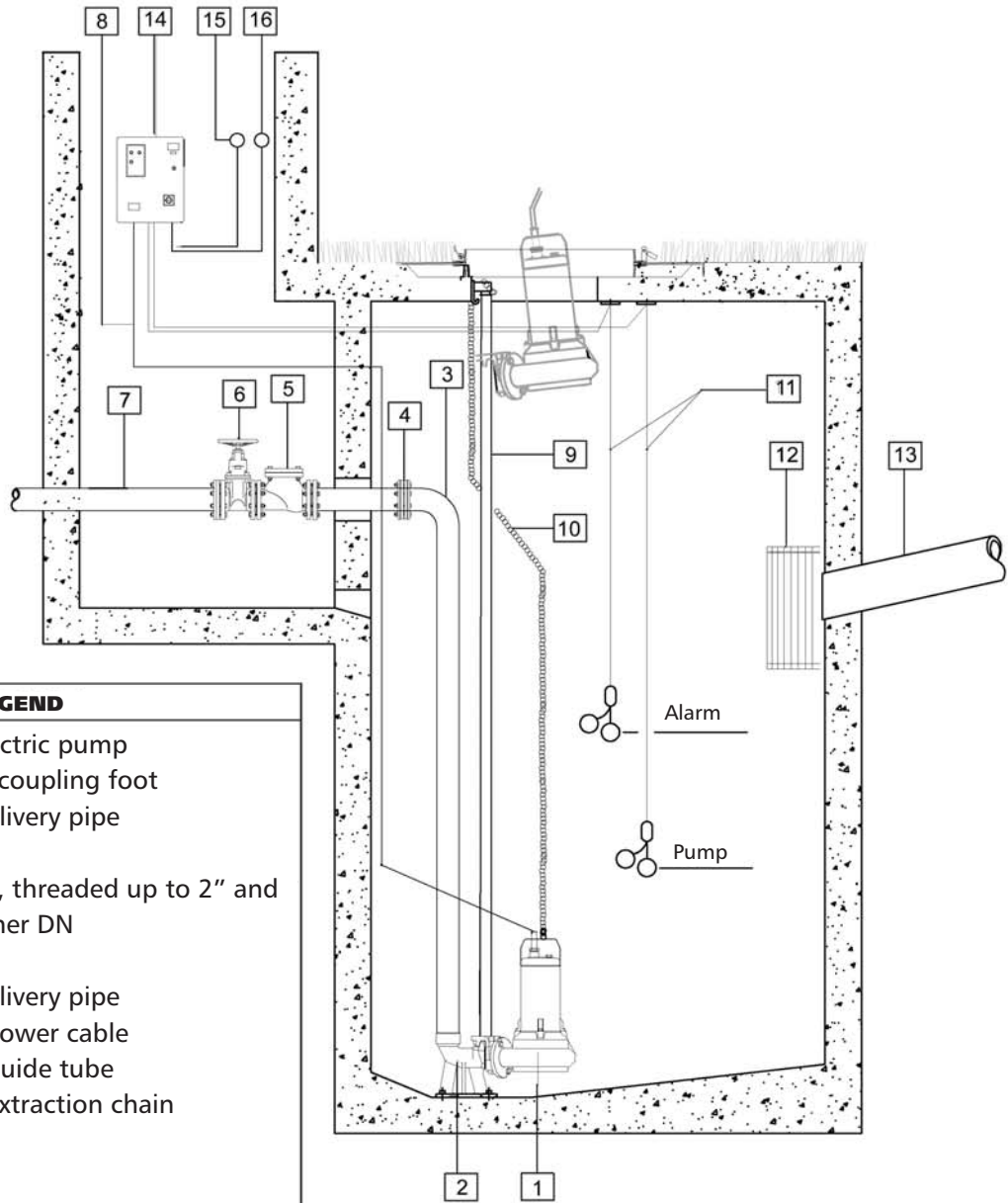

LEGEND	
1	Submersible electric pump
2	Cast iron quick coupling foot
3	Polyethylene delivery pipe
4	Counterflange
5	Ball check valve, threaded up to 2" and flanged for higher DN
6	Gate valve
7	Polyethylene delivery pipe
8	Electric pump power cable
9	Stainless steel guide tube
10	Stainless steel extraction chain
11	Level floats
12	Inlet sluice gate
13	Inlet pipe
14	Electric panel
15	Alarm siren
16	Alarm light

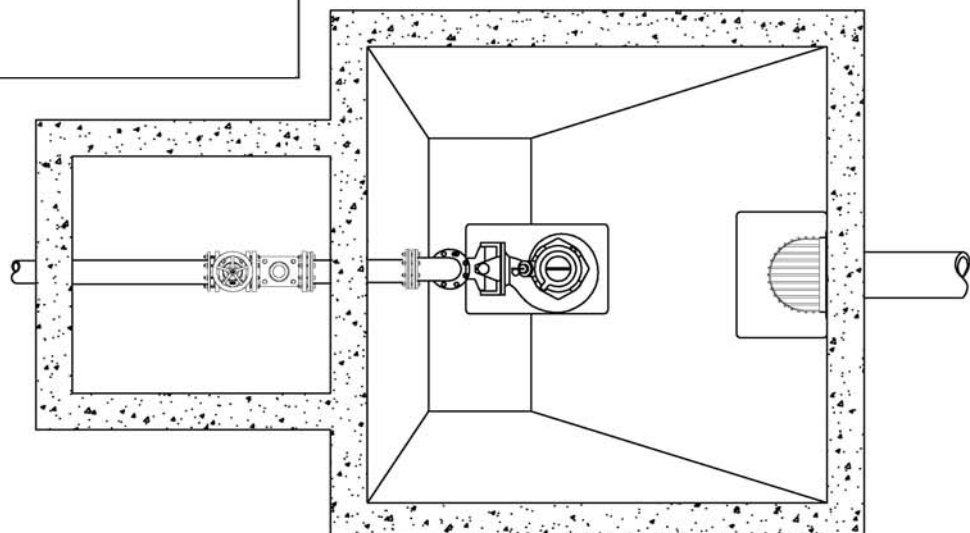



EXAMPLE OF INSTALLATION OF TWO-PUMP SYSTEM WITH THREE FLOATS

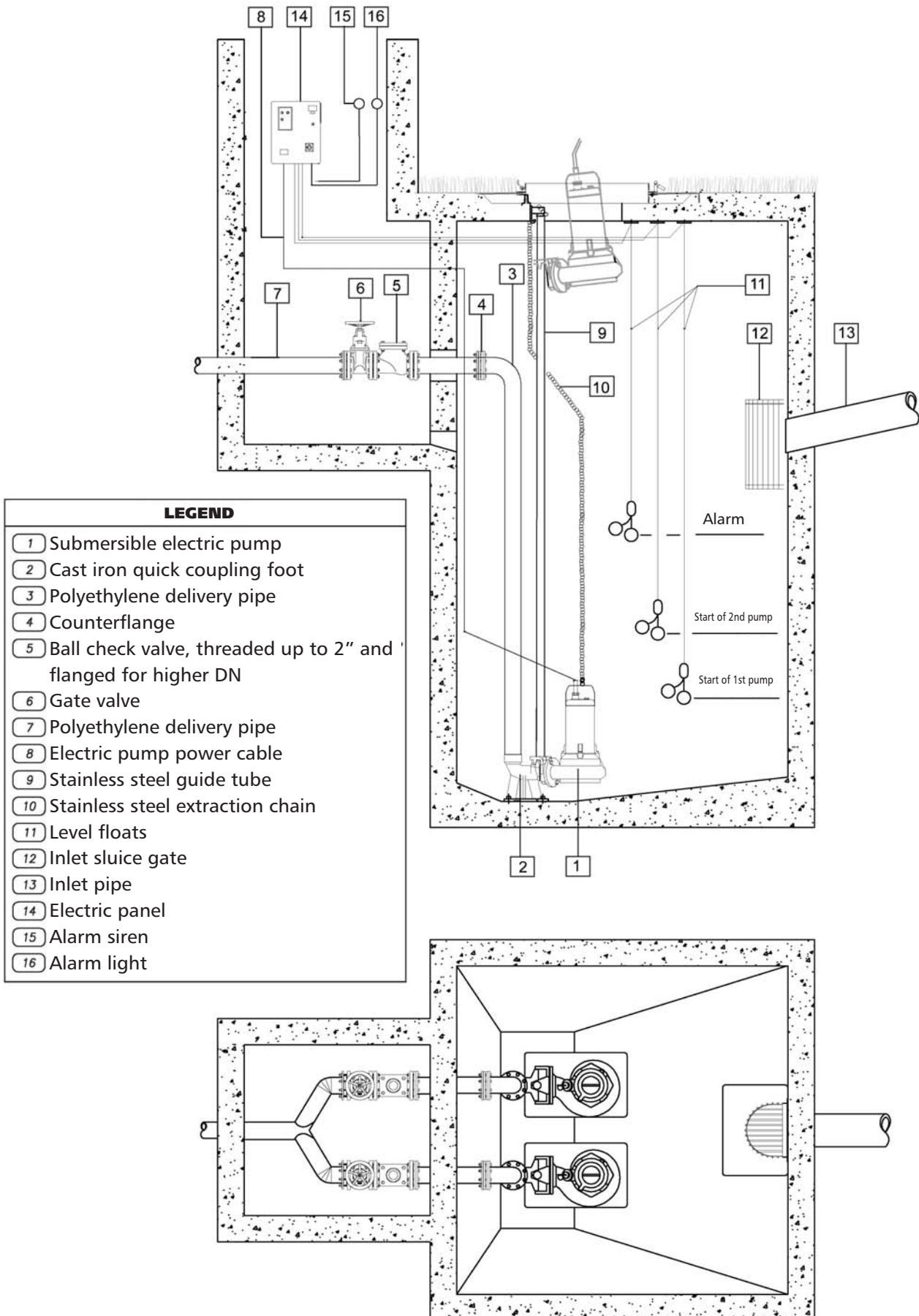



EXAMPLE OF INSTALLATION OF TWO-PUMP SYSTEM WITH FOUR FLOATS

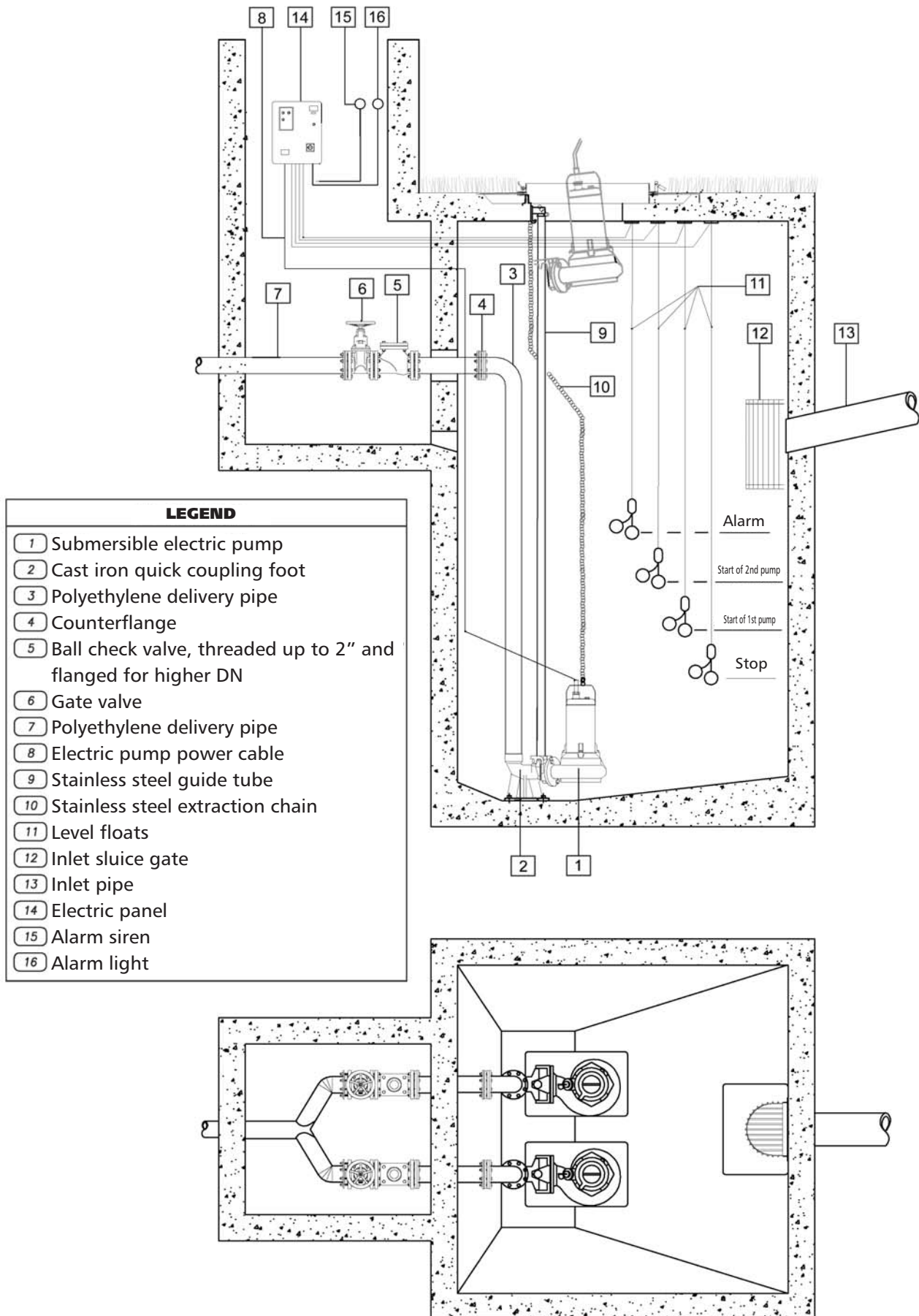

LEVEL CONTROL FLOAT

SMALL MODEL

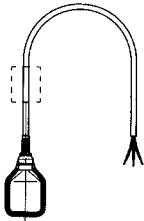

For single function (draining)
 cable length 1.5, 5, 10 m.
 Counterweight available on request for
 version with 5, 10 m cable.

KEY MODEL

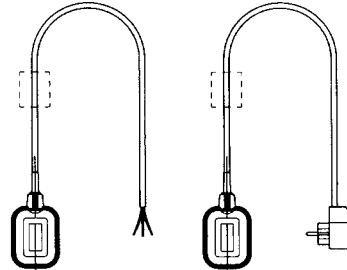

For dual function (draining/filling)
 cable length 1.5, 5, 10, 20 m.
 Counterweight available on request for
 version with 5, 10 m cable.
 Version with plug and socket for
 single-phase pumps up to 1 kW.

RDN-10 MODEL

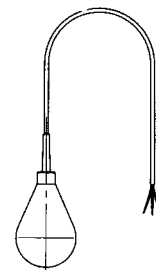

For solids-laden water.
 Cable length: 15 m. (PVC)

BALL CHECK VALVE FOR SOLIDS-LADEN WATER

No-clog, maximum reliability, low flow resistance.
 Maximum operating pressure: 10 bar.
 Maximum temperature: 85°C.
 Horizontal or vertical operating position.

MODEL	DIMENSIONS (mm)			WEIGHT kg
	Ø BALL	L	H	
Rp 1 1/4	48	140	80	2
Rp 1 1/2	50	140	80	4
Rp 2	60	200	98	5,5
DN 65	95	230	148	12
DN 80	95	260	148	13
DN 100	120	300	182	18
DN 150	175	400	251	37,5
DN 200	240	500	333	70
DN 250	300	600	406	128

Valv-palla-en_a_td

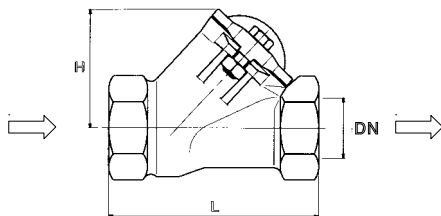

Rp 1 1/4 - 1 1/2 - 2 MODEL

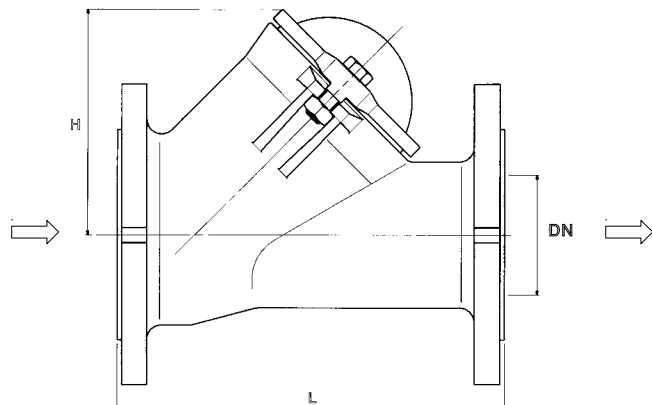

65 - 80 - 100 - 150 - 200 - 250 MODEL



FLOW RESISTANCE

TABLE OF FLOW RESISTANCE IN 100 m OF A NEW AND STRAIGHT CAST IRON PIPELINE

FLOW RATE		NOMINAL DIAMETER IN mm AND INCHES																	
m ³ /h	l/min.	15 1/2"	20 3/4"	25 1"	32 1 1/4"	40 1 1/2"	50 2"	65 2 1/2"	80 3"	100 4"	125 5"	150 6"	175 7"	200 8"	250 10"	300 12"	350 14"	400 16"	
0,6	10	V	0,94	0,53	0,34	0,21													
		hr	11,8	2,82	1	0,25													
0,9	15	V	1,42	0,8	0,51	0,31													
		hr	25,1	6,04	2,16	0,55													
1,2	20	V	1,89	1,06	0,68	0,41	0,27												
		hr	43,1	10,4	3,72	0,95	0,31												
1,5	25	V	2,36	1,33	0,85	0,52	0,33												
		hr	64,5	15,8	5,68	1,47	0,47												
1,8	30	V	2,83	1,59	1,02	0,62	0,4												
		hr	92	22,3	8	2,09	0,66												
2,1	35	V	3,3	1,86	1,19	0,73	0,46	0,3											
		hr	123	29,8	10,8	2,81	0,89	0,31											
2,4	40	V	3,77	2,12	1,36	0,83	0,53	0,34											
		hr	164	38,2	13,8	2,65	1,15	0,4											
3	50	V	4,72	2,65	1,7	1,04	0,66	0,42											
		hr	246	58,2	21,5	5,6	1,75	0,61											
3,6	60	V		3,18	2,04	1,24	0,8	0,51											
		hr		82	30	8	2,48	0,86											
4,2	70	V		3,72	2,38	1,45	0,93	0,59											
		hr		110	40	10,8	3,33	1,14											
4,8	80	V		4,25	2,72	1,66	1,06	0,68											
		hr		141	51,5	13,9	4,3	1,46											
5,4	90	V			3,06	1,87	1,19	0,76	0,45										
		hr			64	17,5	5,4	1,82	0,46										
6	100	V			3,4	2,07	1,33	0,85	0,5										
		hr			79	21,4	6,6	2,22	0,56										
7,5	125	V			4,25	2,59	1,66	1,06	0,63										
		hr			120	33	10	3,4	0,86										
9	150	V				3,11	1,99	1,27	0,75	0,5									
		hr				47	14,2	4,74	1,21	0,43									
10,5	175	V				3,63	2,32	1,49	0,88	0,58									
		hr				63	19	6,3	1,63	0,57									
12	200	V				4,15	2,65	1,7	1,01	0,66									
		hr				82	24,5	8,1	2,1	0,74									
15	250	V				5,18	3,32	2,12	1,26	0,83	0,53								
		hr				126	37,5	12,3	3,2	1,12	0,36								
18	300	V					3,98	2,55	1,51	1	0,64								
		hr					53	17,3	4,5	1,58	0,51								
24	400	V					5,31	3,4	2,01	1,33	0,85								
		hr					92	29,5	7,8	2,7	0,89								
30	500	V					6,63	4,25	2,51	1,66	1,06	0,68							
		hr					140	44,8	12	4,13	1,36	0,48							
36	600	V						5,1	3,02	1,99	1,27	0,82							
		hr						63	16,9	5,8	1,93	0,68							
42	700	V						5,94	3,52	2,32	1,49	0,95							
		hr						84	22,6	7,8	2,6	0,9							
48	800	V						6,79	4,02	2,65	1,70	1,09	0,75						
		hr						108	29	10	3,35	1,16	0,43						
54	900	V						7,64	4,52	2,99	1,91	1,22	0,85						
		hr						134	36	12,5	4,2	1,45	0,54						
60	1000	V						5,03	3,32	2,12	1,36	0,94							
		hr						44,5	15,2	5,14	1,76	0,66							
75	1250	V						6,28	4,15	2,65	1,70	1,18	0,87						
		hr						68	23	7,9	2,68	1	0,48						
90	1500	V						7,54	4,98	3,18	2,04	1,42	1,04						
		hr						96	32,6	11,2	3,77	1,42	0,68						
105	1750	V						8,79	5,81	3,72	2,38	1,65	1,21	0,93					
		hr						129	43,5	15	5,04	1,9	0,91	0,45					
120	2000	V						6,63	4,25	2,72	1,89	1,39	1,06	0,68					
		hr						56	19,4	6,5	2,43	1,18	0,58	0,16					
150	2500	V						8,29	5,31	3,40	2,36	1,73	1,33	0,85					
		hr						85	30	9,8	3,75	1,79	0,89	0,25					
180	3000	V						9,95	6,37	4,08	2,83	2,08	1,59	1,02	0,71				
		hr						120	42	13,8	5,3	2,53	1,25	0,35	0,15				
300	5000	V							10,62	6,79	4,72	3,47	2,65	1,70	1,18	0,87	0,66		
		hr							124,9	41,3	16,74	7,81	4,03	1,34	0,54	0,25	0,13		
600	10000	V								13,59	9,44	6,93	5,31	3,4	2,36	1,73	1,33	0,85	
		hr								161	65	30,2	15,6	5,16	2,09	0,97	0,5		
1200	20000	V												6,79	4,72	3,47	2,65	1,70	1,18
		hr												20,1	8,13	3,8	2,65	1,70	1,18
1800	30000	V														7,7	5,2	4,0	
		hr														18,07	8,39	4,32	
3000	50000	V														11,8	8,67	6,63	
		hr														49,5	23	11,8	
4500	75000	V														17,7	13	9,9	
		hr														110,5	51,3	26,4	
6000	100000	V															17,33	13,27	
		hr															90,6	46,6	

THE FLOW RESISTANCE MUST BE MULTIPLIED BY:

- 0.8 for stainless steel pipes
- 1.25 for slightly rusted steel pipes
- 1.7 for pipes with deposits that reduce the flow section
- 0.7 for aluminium pipes
- 1.3 for fibre-cement pipes

Hr = FLOW RESISTANCE (m/100 m OF PIPELINE)
V = WATER SPEED (m/sec)

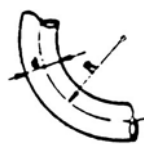

FLOW RESISTANCE IN BENDS, VALVES AND GATES IN cm OF COLUMN OF WATER

WATER SPEED m/ ec	SHARP BENDS 					SMOOTH BENDS 					STANDARD GATE VALVES	FOOT VALVES	CHECK VALVES
	a = 30°	a = 40°	a = 60°	a = 80°	a = 90°	$\frac{d}{R} = 0,4$	$\frac{d}{R} = 0,6$	$\frac{d}{R} = 0,8$	$\frac{d}{R} = 1$	$\frac{d}{R} = 1,5$			
0,10	0,03	0,04	0,05	0,07	0,08	0,007	0,008	0,01	0,0155	0,027	0,030	30	30
0,15	0,06	0,07	0,10	0,14	0,17	0,016	0,019	0,024	0,033	0,06	0,033	31	31
0,2	0,11	0,13	0,18	0,26	0,31	0,028	0,033	0,04	0,058	0,11	0,058	31	31
0,25	0,17	0,21	0,28	0,4	0,48	0,044	0,052	0,063	0,091	0,17	0,090	31	31
0,3	0,25	0,30	0,41	0,6	0,7	0,063	0,074	0,09	0,13	0,25	0,13	31	31
0,35	0,33	0,40	0,54	0,8	0,93	0,085	0,10	0,12	0,18	0,33	0,18	31	31
0,4	0,43	0,52	0,71	1,0	1,2	0,11	0,13	0,16	0,23	0,43	0,23	32	31
0,5	0,67	0,81	1,1	1,6	1,9	0,18	0,21	0,26	0,37	0,67	0,37	33	32
0,6	0,97	1,2	1,6	2,3	2,8	0,25	0,29	0,36	0,52	0,97	0,52	34	32
0,7	1,35	1,65	2,2	3,2	3,9	0,34	0,40	0,48	0,70	1,35	0,70	35	32
0,8	1,7	2,1	2,8	4,0	4,8	0,45	0,53	0,64	0,93	1,7	0,95	36	33
0,9	2,2	2,7	3,6	5,2	6,2	0,57	0,67	0,82	1,18	2,2	1,20	37	34
1,0	2,7	3,3	4,5	6,4	7,6	0,7	0,82	1,0	1,45	2,7	1,45	38	35
1,5	6,0	7,3	10	14	17	1,6	1,9	2,3	3,3	6	3,3	47	40
2,0	11	14	18	26	31	2,8	3,3	4,0	5,8	11	5,8	61	48
2,5	17	21	28	40	48	4,4	5,2	6,3	9,1	17	9,1	78	58
3,0	25	30	41	60	70	6,3	7,4	9	13	25	13	100	71
3,5	33	40	55	78	93	8,5	10	12	18	33	18	123	85
4,0	43	52	70	100	120	11	13	16	23	42	23	150	100
4,5	55	67	90	130	160	14	21	26	37	55	37	190	120
5,0	67	82	110	160	190	18	29	36	52	67	52	220	140

- 1) Flow resistance in bends is due to the contraction of the liquid threads resulting from the change of direction: the development of the bends must therefore be included in the length of the pipeline.
- 2) Flow resistance in valves and gates was determined on the basis of practical tests.



VOLUMETRIC CAPACITY

Litres per minute l/min	Cubic metres per hour m ³ /h	Cubic feet per hour ft ³ /h	Cubic feet per minute ft ³ /min	Imp. gal. per minute Imp. gal./min	US gal. per minute Us gal./min
1,0000	0,0600	2,1189	0,0353	0,2200	0,2640
16,6667	1,0000	35,3147	0,5886	3,6660	4,4030
0,4720	0,0283	1,0000	0,0167	0,1040	0,1250
28,3170	1,6990	60,0000	1,0000	6,2290	7,4800
4,5460	0,2728	9,6326	0,1605	1,0000	1,2010
3,7850	0,2271	8,0209	0,1337	0,8330	1,0000

PRESSURE AND HEAD

Newton per square metre N/m ²	kilo Pascal kPa	bar bar	Pound force per square inch psi	metre of water m H ₂ O	millimetre di mercury mm Hg
1,0000	0,0010	1 x 10 ⁻⁵	1,45 x 10 ⁻⁴	1,02 x 10 ⁻⁴	0,0075
1000,0000	1,0000	0,0100	0,1450	0,1020	7,5000
1 x 10 ⁵	100,0000	1,0000	14,5000	10,2000	750,1000
6895,0000	6,8950	0,0690	1,0000	0,7030	51,7200
9789,0000	9,7890	0,0980	1,4200	1,0000	73,4200
133,3000	0,1333	0,0013	0,0190	0,0140	1,0000

LENGHT

millimetre mm	centimetre cm	metre m	inch in	foot ft	yard yd
1,0000	0,1000	0,0010	0,0394	0,0033	0,0011
10,0000	1,0000	0,0100	0,3937	0,0328	0,0109
1000,0000	100,0000	1,0000	39,3701	3,2808	1,0936
25,4000	2,5400	0,0254	1,0000	0,0833	0,0278
304,8000	30,4800	0,3048	12,0000	1,0000	0,3333
914,4000	91,4400	0,9144	36,0000	3,0000	1,0000

VOLUME

cubic metre m ³	litre litro	millilitre ml	imp. gallon imp. gal.	US gallon US gal.	cubic foot ft ³
1,0000	1000,0000	1 x 10 ⁶	220,0000	264,2000	35,3147
0,0010	1,0000	1000,0000	0,2200	0,2642	0,0353
1 x 10 ⁻⁶	0,0010	1,0000	2,2 x 10 ⁻⁴	2,642 x 10 ⁻⁴	3,53 x 10 ⁻⁵
0,0045	4,5460	4546,0000	1,0000	1,2010	0,1605
0,0038	3,7850	3785,0000	0,8327	1,0000	0,1337
0,0283	28,3170	28317,0000	6,2288	7,4805	1,0000

G-at_pp-en_a_sc

ITT Lowara part of ITT Corporation and headquarters of "Residential and Commercial Water - EMEA".

World leading in offering high reliable fluid handling solutions for Building Services, Irrigation and Industrial applications. We provide a complete range of high quality pumps, packaged systems and controls and are specialized in engineering and manufacturing stainless steel products.

ITT Lowara is headquartered in Vicenza, Italy and operates in more than 80 countries across the world with own plants in Italy, Austria, Poland and Hungary. The company has 1.300 employees and generated 2008 sales exceeding \$440 million. ITT Lowara is wholly owned by the ITT Corporation of White Plains, New York, and is the EMEA headquarter of ITT's Residential and Commercial Water division. ITT Corporation is a high-technology engineering and manufacturing company operating on all seven continents in three vital markets: water and fluids management, global defense and security, and motion and flow control. ITT Corporation generated 2008 sales of \$11.7 billion

ITT RESIDENTIAL AND COMMERCIAL WATER DIVISION - EMEA**Headquarters**

LOWARA S.r.l.
Via Dott. Lombardi, 14
36075 Montecchio Maggiore
Vicenza - Italy
Tel. (+39) 0444 707111
Fax (+39) 0444 492166
e-mail: lowara.mkt@itt.com
http://www.lowara.com

AUSTRIA
ITT AUSTRIA GmbH
A-2000 STOCKERAU
Ernst Vogel-Straße 2
Tel. (+43) 02266 604
Fax (+43) 02266 65311
e-mail: info.ittaustria@itt.com
http://www.ittaustria.com

FRANCE
LOWARA FRANCE S.A.S.
BP 57311
37073 Tours Cedex 2
Tel. (+33) 02 47 88 17 17
Fax (+33) 02 47 88 17 00
e-mail: lowarafr.info@itt.com
http://www.lowara.fr

GERMANY
LOWARA DEUTSCHLAND GMBH
Biebigheimer Straße 12
D-63762 Grobostheim
Tel. (+49) 0 60 26 9 43 - 0
Fax (+49) 0 60 26 9 43 - 2 10
e-mail: lowarade.info@itt.com
http://www.lowara.de

IRELAND
ITT IRELAND
50 Broomhill Close
Airton Road
Tallaght
DUBLIN 24
Tel. (+353) 01 4524444
Fax (+353) 01 4524795
e-mail: lowara.ireland@itt.com -
http://www.lowara.ie

NEDERLAND
LOWARA NEDERLAND B.V.
Zandweistraat 22
4181 CG Waardenburg
Tel. (+31) 0418 655060
Fax (+31) 0418 655061
e-mail: lowaranl.info@itt.com
http://www.lowara.nl

POLAND
LOWARA VOGEL POLSKA Sp. z o.o.
PL 57-100 Strzelin
ul. Kazimierza Wielkiego 5
Tel. (+48) 071 769 3900 - Fax (+48) 071 769 3909
e-mail: info.lowarapl@itt.com -
http://www.lowara-voegel.pl

PORTUGAL
ITT PORTUGAL, Lda
Praçeta da Castanheira, 38
4475-019 Barca
Tel. (+351) 22 9478550
Fax (+351) 22 9478570
e-mail: info.pt@itt.com
http://www.itt.pt

RUSSIA
LOWARA Moscow
Kalanchevskaya st. 11 b.2, off. 334
107078 Moscow
Tel. (+7) 495 631 55 15
Fax (+7) 495 631 59 72
info.lowararu@itt.com - www.lowara.ru

UK
LOWARA UK LTD.
Millwey Rise, Industrial Estate
Axminster - Devon EX13 5HU UK
Tel. (+44) 01297 630200
Fax (+44) 01297 630270
e-mail: lowaraukenquiries@itt.com
http://www.lowara.co.uk

For additional addresses, please visit
www.lowara.com

cod. 191004441 W 06/09

Lowara reserves the right to make modifications
without prior notice.